

# SERVICE MANUAL

# BC-5 CHASSIS

<u>MODEL</u>	<u>COMMANDER</u>	<u>DEST.</u>	<u>CHASSIS NO.</u>	<u>MODEL</u>	<u>COMMANDER</u>	<u>DEST.</u>	<u>CHASSIS NO.</u>
<i>KV-14FV1B</i>	<i>RM-C816</i>	<i>FR</i>	<i>SCC-xxxx-A</i>	<i>KV-21FV1B</i>	<i>RM-C816</i>	<i>FR</i>	<i>SCC-xxxx-A</i>
<i>KV-14FV1D</i>	<i>RM-C814</i>	<i>AEP</i>	<i>SCC-xxxx-A</i>	<i>KV-21FV1D</i>	<i>RM-C814</i>	<i>AEP</i>	<i>SCC-xxxx-A</i>
<i>KV-14FV1E</i>	<i>RM-C814</i>	<i>ESP</i>	<i>SCC-Q62B-A</i>	<i>KV-21FV1E</i>	<i>RM-C814</i>	<i>ESP</i>	<i>SCC-Q62A-A</i>
<i>KV-14FV1U</i>	<i>RM-C815</i>	<i>UK</i>	<i>SCC-xxxx-A</i>	<i>KV-21FV1U</i>	<i>RM-C815</i>	<i>UK</i>	<i>SCC-xxxx-A</i>

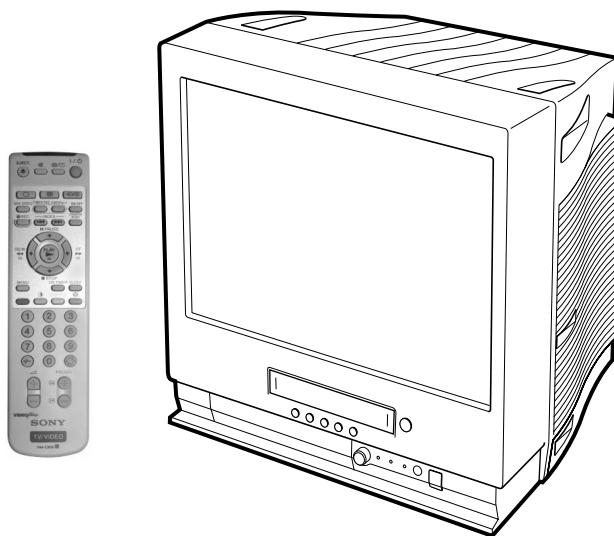

\* Please file according to model size. ....

## SPECIFICATIONS

### TV Section

**TV system:**

I

**Colour system:**

PAL, SECAM

NTSC 3.58, 4.43 (only Video In)

**Channel Coverage:**

UHF: B-21, B69

**Picture Tube:**

- KV-14FV1U:  
Flat Display Trinitron.  
14" (approx. 37 cm. measured diagonally)
- KV-21FV1U:  
Flat Display Trinitron.  
21" (approx. 55 cm. measured diagonally)

### VCR Section

**Format:**

VHS Standard

**Video recording system:**

Rotary 2-head helical scanning system

**Audio recording system:**

Monaural

**Video signal:**

This Video TV is designated to receive TV programmes based on PAL (I) colour system and to record and play on PAL system. The Video TV can also play tapes on NTSC colour system.

**Tape speed:**

PAL:

SP: 23.39 mm/sec.

LP: 11.70 mm/sec.

NTSC (playback only):

SP: 33.35 mm/sec.

LP: 11.12 mm/sec.



**Maximum recording time:**

SP: 4 hours with E-240 tape

LP: 8 hours with E-240 tape

### General

**Rear Terminals**

1/  21-pin scart connector (CENELEC standard) including audio/video input, RGB input, TV audio/video output.

**Front Terminals**

2 video input – phono jack

2 audio input – phono jack

 headphones jack

**Clock**

Quartz locked

**Clock back up**

Approx. 7 days

**Power requirements**

220-240 V AC, 50Hz

**Sound Output:**

1 x 6W (music power)

1 x 3W (RMS Mono)

**Power Consumption:**

- KV-14FV1U: 86 W
- KV-21FV1U: 107 W

**Standby Power Consumption:**

< 2 W

**Dimensions:**

- KV-14FV1U: Approx. 375 x 398 x 407 mm.
- KV-21FV1U: Approx. 489 x 500 x 477 mm.

**Weight:**

- KV-14FV1U: Approx. 15.6 Kg.
- KV-21FV1U: Approx. 27.2 Kg.

**Accessories supplied:**

1 Remote Control (RM-C815)

2 Batteries (IEC designated)

**Other features:**

Teletext, Fasttext, TOPtext

Sleep Timer

Wake UP Timer

Parental Lock

Auto Head Cleaner

Dial Timer

VideoPlus+

Design and specifications are subject to change without notice.

## TABLE OF CONTENTS

<u>Section</u>	<u>Title</u>	<u>Page</u>	<u>Section</u>	<u>Title</u>	<u>Page</u>
<b>SELF DIAGNOSIS FUNCTION</b> .....			<b>4. CIRCUIT ADJUSTMENTS</b>		
<b>[ TV SECTION ]</b>			4-1. Adjustments with Commander .....		
<b>1. GENERAL</b> .....		4	4-2. Adjustment Method .....		
		7	4-3. Service Data .....		
<b>2. DISASSEMBLY</b>			4-4. A Board Adjustment .....		
2-1. Rear Cover Removal .....		16	<b>5. DIAGRAMS</b>		
2-2. Chassis Assy Removal .....		16	5-1. Block Diagrams .....		
2-3. Service Position (A Board) .....		16	5-2. Circuit Boards Location .....		
2-4. A Board Removal .....		16	5-3. Printed Wiring Boards and Schematic Diagrams ....		
2-5. Harnes Location .....		17	• A Board .....		
2-6. Picture Tube Removal .....		18	• CVM Board .....		
<b>3. SET-UP ADJUSTMENTS</b>			<b>6. EXPLODED VIEWS</b>		
3-1. Beam Landing .....		19	6-1. Picture Tube .....		
3-2. Convergence .....		20	6-2. Chassis .....		
3-3. Focus Adjustment .....		21	<b>7. ELECTRICAL PARTS LIST</b> .....		
3-4. Screen (G2) Adjustment .....		21			
3-5. White Barance Adjustment .....		22	<b>[ VIDEO SECTION ]</b>		
3-6. Picture Distortion Adjustment .....		22	<b>1. GENERAL</b> .....		
			<b>2. DISASSEMBLY</b> .....		
			<b>3. CIRCUIT ADJUSTMENTS</b> .....		
			<b>4. INTERFACE, IC PIN FUNCTION</b>		
			DESCRIPTION .....		
			<b>5. DIAGRAMS</b> .....		
			<b>6. EXPLODED VIEWS</b> .....		
			<b>7. ELECTRICAL PARTS LIST</b> .....		

### CAUTION

SHORT CIRCUIT THE ANODE OF THE PICTURE TUBE AND THE ANODE CAP TO THE METAL CHASSIS, CRT SHIELD, OR CARBON PAINTED ON THE CRT, AFTER REMOVING THE ANODE.

### SAFETY-RELATED COMPONENT WARNING!!

COMPONENTS IDENTIFIED BY SHADING AND MARK  $\triangle$  ON THE SCHEMATIC DIAGRAMS, EXPLODED VIEWS AND IN THE PARTS LIST ARE CRITICAL FOR SAFE OPERATION. REPLACE THESE COMPONENTS WITH SONY PARTS WHOSE PART NUMBERS APPEAR AS SHOWN IN THIS MANUAL OR IN SUPPLEMENTS PUBLISHED BY SONY. CIRCUIT ADJUSTMENTS THAT ARE CRITICAL FOR SAFE OPERATION ARE IDENTIFIED IN THIS MANUAL. FOLLOW THESE PROCEDURES WHENEVER CRITICAL COMPONENTS ARE REPLACED OR IMPROPER OPERATION IS SUSPECTED.

### ATTENTION

APRES AVIOR DECONNECTE LE CAP DE L'ANODE, COURT-CIRCUITER L'ANODE DU TUBE CATHODIQUE ET CELUI DE L'ANODE DU CAP AU CHASSIS METALLIQUE DE L'APPAREIL, OU AU COUCHE DE CARBONE PEINTE SUR LE TUBE CATHODIQUE OU AU BLINDAGE DU TUBE CATHODIQUE.

### ATTENTION AUX COMPOSANTS RELATIFS À LA SÉCURITÉ!!

LES COMPOSANTS IDENTIFIÉS PAR UNE TRAME ET PAR UNE MARQUE  $\triangle$  SUR LES SCHÉMAS DE PRINCIPE, LES VUES EXPLOSÉES ET LES LISTES DE PIÈCES SONT D'UNE IMPORTANCE CRITIQUE POUR LA SÉCURITÉ DU FONCTIONNEMENT. NE LES REMPLACER QUE PAR DES COMPOSANTS SONY DONT LE NUMÉRO DE PIÈCE EST INDIQUÉ DANS LE PRÉSENT MANUEL OU DANS DES SUPPLÉMENTS PUBLIÉS PAR SONY. LES RÉGLAGES DE CIRCUIT DONT L'IMPORTANCE EST CRITIQUE POUR LA SÉCURITÉ DU FONCTIONNEMENT SONT IDENTIFIÉS DANS LE PRÉSENT MANUEL. SUIVRE CES PROCÉDURES LORS DE CHAQUE REMPLACEMENT DE COMPOSANTS CRITIQUES, OU LORSQU'UN MAUVAIS FONCTIONNEMENT EST SUSPECTÉ.

## SELF DIAGNOSTIC FUNCTION

### 1. OUTLINE

- The units in this manual contain a self-diagnostic function.
- If an error occurs, the STANDBY lamp will automatically begin to flash.  
The number of times the lamp flashes translates to a probable source of the problem. A definition of the STANDBY lamp flash indicators is listed in the instruction manual for the user's knowledge and reference.
- If an error symptom cannot be reproduced, the remote commander can be used to review the failure occurrence data stored in memory to reveal past problems and how often these problems occur.

### 2. DIAGNOSTIC TEST INDICATORS

- When an errors occurs, the STANDBY lamp will flash a set number of times to indicate the possible cause of the problem. If there is more than one error, the lamp will identify the first of the problem areas.
- Result for all of the following diagnostic items are displayed on screen. No error has occurred if the screen displays a "0".

Diagnostic Item Description	No. of times STANDBY lamp flashes	Self-diagnostic display/Diagnostic result	Probable Cause Location	Detected Symptoms
• Power does not turn on	Does not light	—	<ul style="list-style-type: none"> <li>• Power cord is not plugged in.</li> <li>• Fuse is burned out F1701</li> </ul>	<ul style="list-style-type: none"> <li>• Power does not come on.</li> <li>• No power is supplied to the TV.</li> <li>• AC power supply is faulty.</li> </ul>
• +B overcurrent (OCP) or overvoltage (OVP)	2 times	2 : 0 or 2 : 1 4 : 1 ] at the same time (Note 1)	<ul style="list-style-type: none"> <li>• FBT</li> <li>• Q802 (H OUT) shorted</li> </ul>	<ul style="list-style-type: none"> <li>• On standby state.</li> <li>• Load on power line is shorted (at the same time 4 : 1 on display).</li> </ul>
• Vertical deflection stopped	4 times	4 : 0 or 4 : 1	<ul style="list-style-type: none"> <li>• IC501</li> <li>• IC301 (14) pin</li> <li>• IC606</li> <li>• Q802 (H OUT) shorted</li> <li>• Q803</li> <li>• Q608</li> <li>• R803 open</li> </ul>	<ul style="list-style-type: none"> <li>• Has entered standby state after horizontal raster.</li> <li>• Vertical deflection pulse is stopped.</li> <li>• Horizontal deflection stopped.</li> <li>• Power line is shorted or power supply is stopped.</li> </ul>
• White balance failure (no PICTURE)	5 times	5 : 0 or 5 : 1	<ul style="list-style-type: none"> <li>• CRT</li> <li>• IC301</li> <li>• Q701 - Q717 (CVM board)</li> <li>• G2 is improperly adjusted. (Note 2)</li> </ul>	<ul style="list-style-type: none"> <li>• No raster is generated.</li> <li>• CRT cathode current detection reference pulse output is small.</li> </ul>

Note 1: If a + B overcurrent is detected, stoppage of the vertical deflection is detected simultaneously.  
The symptom that is diagnosed first by the microcontroller is displayed on the screen.

Note 2: Refer to screen (G2) Adjustment in section 3-4 of this manual.

#### • VCR EMG code List

Code	Contents	Code	Contents
00h	NO EMG	30h	Capstan FG NG at initial
10h	CAM encode NG during unloading	31h	Capstan FG NG
11h	CAM encode NG during unloading	40h	Drum FG NG
12h	CAM encode NG at initial	41h	Drum FG NG at initial
20h	T reel NG during unloading	42h	Drum FG NG
21h	S reel FG NG	43h	Drum PG NG
22h	T reel FG NG	44h	Drum PG NG
23h	S reel FG NG	50h	DEW
24h	T reel FG NG at initial	60h	FL NG
25h	S reel FG NG at initial	70h	DEW eject NG

### 3. DISPLAY OF STANDBY LIGHT FLASH COUNT

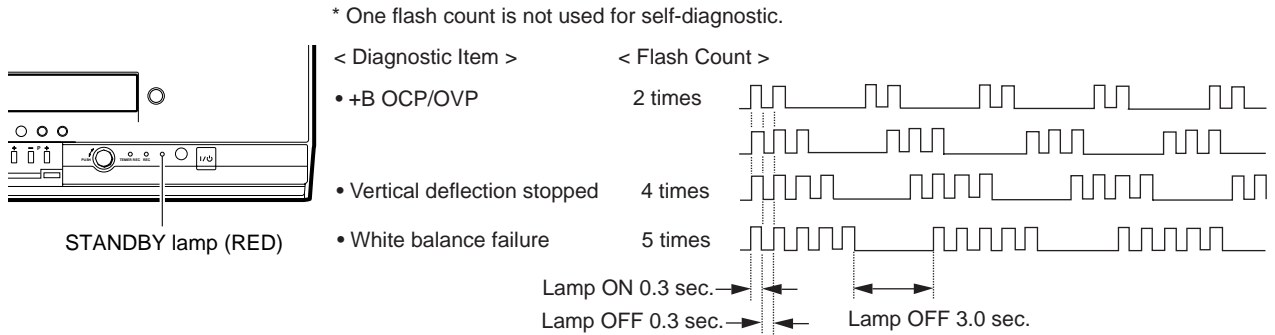

#### STOPPING THE STANDBY FLASH

- Turn off the power switch on the TV main unit or unplug the power cord from the outlet to stop the STANDBY lamp from flashing.

### 4. SELF-DIAGNOSTIC SCREEN DISPLAY

- For errors with symptoms such as “power sometimes shuts off” or “screen sometimes goes out” that cannot be confirmed, it is possible to bring up past occurrences of failure for confirmation on the screen:

#### [To Bring Up Screen Test]

- In standby mode, press buttons on the remote commander sequentially in rapid succession as shown below:

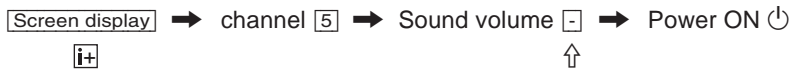

Note that this differs from entering the service mode (mode volume [±]).

#### Self-Diagnosis screen display

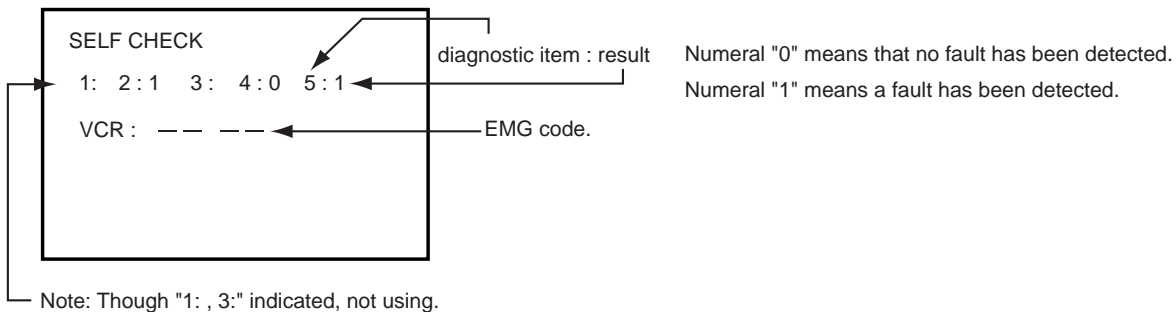

### 5. HANDLING OF SELF-DIAGNOSTIC SCREEN DISPLAY

- Since the diagnostic results displayed on the screen are not automatically cleared, always check the self-diagnostic screen during repairs. When you have completed the repairs, clear the result display to “0”.
- Unless the result display is cleared to “0”, the self-diagnostic function will not be able to detect subsequent faults after completion of the repairs.

#### [Clearing the result display]

- To clear the result display to “0”, press buttons on the remote commander sequentially as shown below when the diagnostic screen is being displayed.
- Pay attention when perform by the service mode, other all electric adjustment data will be rewrite.

Channel [8] → [0]

#### [Quitting Self-diagnostic screen]

- To quit the entire self-diagnostic screen, turn off the power switch on the remote commander or the main unit.

## 6. SELF-DIAGNOSTIC CIRCUIT

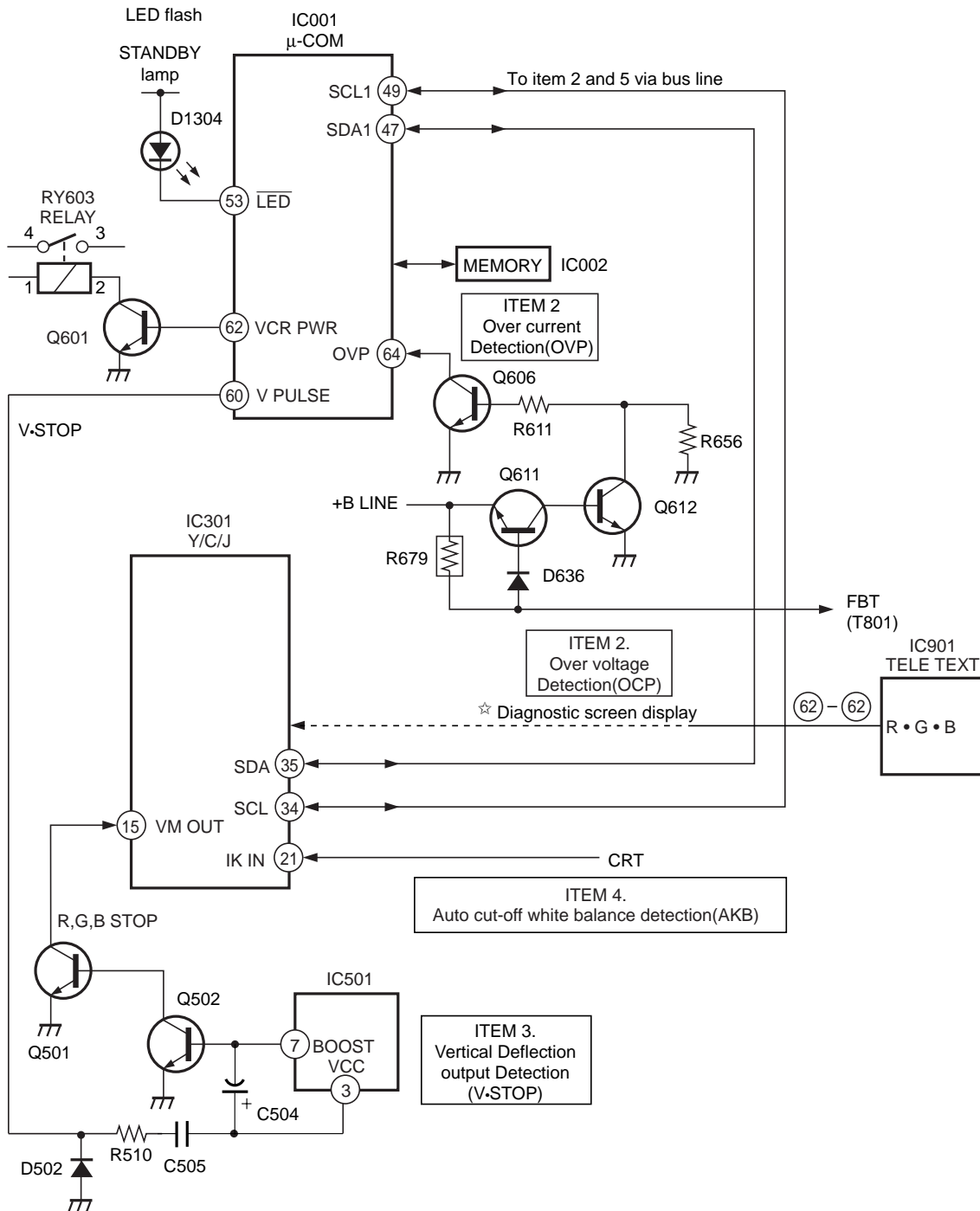

**+B overcurrent**

Owing to current increase voltage of R679 decrease and that it make Q611 and Q612 to become LOW and OFF RY601.

**+B over voltage**

When +B voltage become more than 142.5V, Q611 and Q612 pin become LOW and RY601 OFF.

**Vertical deflection stopped**

Detect Vertical deflection Pulse lost by IC001 60 pin of micro computer. Mute the picture at 15 pin of IC301 that performed by Y/C/J.

**White balance**

Detect when R.G.B. output wrong level balance of automatic white balance detecting standard pulse which detect cathode current, or which become low almost.

## SECTION 1 GENERAL

The operating instructions mentioned here are partial abstracts from the Operating Instruction Manual. The page numbers of the Operating Instruction Manual remain as in the manual.

### Overview of Remote Control Buttons

**Muting the Sound**  
Press to mute TV sound. Press again to restore the sound.

**Displaying on Screen information**  
Press once to display On-Screen indications (first level). Press twice to display On-Screen indications (second level). Press a third time to cancel.

**Temporarily Switch Off the Video TV**  
Press to temporarily switch off the Video TV (the standby indicator  $\odot$  on TV lights up). Press again to switch on the Video TV from standby mode.  
**⚠** By using this button to turn off the Video TV instead of the Main Power on/off button, settings will not be cleared unless that the power is interrupted or you disconnect the AC power cord. In that case settings will be cleared after 7 days.

**Ejecting a videotape**  
Press to eject the videotape

**Selecting Teletext**  
Press to switch on teletext.

**Selecting TV mode**  
Press to switch off teletext or video input.

**VCR Operation buttons**  
For details refer to "VCR Operation" section of this instruction manual.

**Displaying the menu system**  
Press to display the menu on the TV screen. Press again to remove the menu display from the TV screen.

**Selecting Picture mode**  
Press repeatedly to change the picture mode.

**Fastext buttons**  
For details refer to "Teletext" section of this instruction manual.

**Selecting channels**  
Press to select channels.  
For double-digit programme numbers, e.g. 23, press -/- first, then the buttons 2 and 3. If you enter an incorrect first digit, this should be corrected by entering another digit (0-9) and then selecting -/- button again to enter the programme number of your choice.

**Adjusting TV volume**  
Press to adjust the volume of the TV.

**Selecting input source**  
Press repeatedly until the desired input symbol of the source appears on the TV screen.  
• **When MENU is switched on:** Use these buttons to operate the menu system. For details refer to "Introducing and Using the Menu System" of this instruction manual (see page 7).  
• **When MENU is switched off and a tape is inserted:** Use these buttons to operate VCR. For details refer to "Playing a Tape and Additional Tasks" section of this instruction manual (see page 10).

**Sleep Timer**  
For details refer to "Switching Off the Video TV Automatically (Sleep Timer)" section of this instruction manual (see page 9).

**On Timer**  
For details refer to "Switching On the Video TV Automatically (On Timer)" section of this instruction manual (see page 9).

**Selecting the TV Screen format**  
Press to view programmes in 16:9 mode. Press again to return to Normal (4:3) mode.

**Back to the channel last watched**  
Press to watch the last channel selected (watched for at least 5 seconds).

**Selecting channels**  
Press to select the next or previous channel.

### Overview of Video TV Buttons

**Tape transport buttons** (see page 10).

**DIAL TIMER** (see page 12)

**TIMER REC (recording) indicator** (see page 13)

**REC (Recording) button** (see page 11)

Press on the mark  $\downarrow$  on the front of the Video TV to reveal the front control panel.

**Standby indicator**

**Standby on/off button**  
**⚠** By using this button to turn off the Video TV instead of the Main Power on/off button, settings will not be cleared unless that the power is interrupted or you disconnect the AC power cord. In that case settings will be cleared after 7 days.

**Main Power On/Off switch**  
**⚠** If you turn off the Video TV by using this button and you do not turn on it again during 7 days, all the settings will be cleared.

**Volume control buttons**

**Programme Up or Down Buttons (Selects TV channels)**

**Selecting Input source**

**Headphone jack**

**Video Input jack**

**Audio Input jack**

**TIMER REC (recording) on/off button** (see page 13)

**REC (recording) button** (see page 11)

GB

### Inserting Batteries into the Remote Control

- ⚠** Make sure to insert the supplied batteries using the correct polarities. Always remember you dispose of used batteries in an environmental friendly way.



### Connecting the Aerial

- ①** Connecting cables are not supplied.

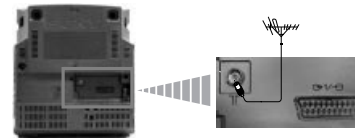



**①** Besides TV functions, all buttons with green symbols are also used for Teletext operation. For more details, please refer to "Teletext" section of this instruction manual (see page 18).

## Switching On the Video TV and Automatically Tuning

**⚠** The first time you switch on your TV, a sequence of menu screen appear on the TV enabling you to: 1) choose the language of the menu screen, 2) search and store all available channels (TV Broadcast), 3) change the order in which the channels (TV Broadcast) appear on the screen and 4) confirm the clock setting. However, if you need to change any of these settings, you can do that by selecting the appropriate menu in the  (Set Up).

**1** Connect the TV plug to the mains socket (220-240V AC, 50Hz)

Press the  main on/off button on the TV set to turn on the Video TV. The first time you press this button, a Language menu displays automatically on the TV screen.

**2** Press the  or  button on the remote control to select the language, then press the **OK** button to confirm your selection. From now on all the menus will appear in the selected language.

**3** The **Auto Tuning** menu appears on the screen. Press the **OK** button to select **Yes**.

**4** A new menu appears on the screen asking you to check that the aerial is connected. Ensure the aerial is connected and then press the **OK** button.

**ⓘ** The Video TV starts to automatically search and store all available channels (TV Broadcast) for you.



**⚠** This procedure could take some minutes. Please be patient and do not press any button. Otherwise the automatic tuning will not be completed.

**5** After all available channels are captioned and stored, the **Programme Sorting** menu appears automatically on the screen enabling you to change the order in which the channels appear on the screen.

**a)** If you do not wish to change the channel order, press **OK** and go to step 6.

**b)** If you wish to change the channel order:

**1** Press the **PROGR** + or - button to select the programme number with the channel (TV Broadcast) you wish to rearrange appears on the screen.

**2** Press the  or  button to select the new programme number position for your selected channel (TV Broadcast), then press the **OK** button.

**ⓘ** The word **Confirm** is highlighted for a few seconds to confirm that the new programme position is stored.

**3** Repeat steps b)1 and b)2 if you wish to change the order of the other channels.

**4** When you finish to rearrange the order of the channels, press **OK**.

**6** The Video TV adjusts itself automatically clock setting, and after few seconds date and time settings are displayed.

If you want to change the time settings, you can adjust it manually through the menu system (for details, see "Setting the Clock Manually" section of this instruction manual (see page 7).

**7** Press the **MENU** button to remove the menu from the screen.

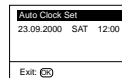
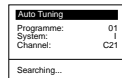
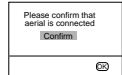
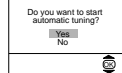
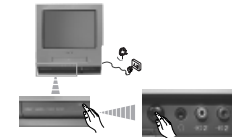

 Your Video TV is now ready for use





## Introducing and Using the Menu System

**ⓘ** Your Video TV uses an on-screen menu system to guide you through the operations. Use the following buttons on the Remote Control to operate the menu system:

**1** Press the **MENU** button to switch the first level menu on.

**2** To highlight the desired menu or option, press  or .

• To enter to the selected menu or option, press .

• To return to the last menu or option, press .

• To alter settings of your selected option, press  /  or  or .





• To confirm and store your selection, press **OK**.

**3** Press the **MENU** button to remove the menu from the screen.



## Picture Adjustment

**ⓘ** The "Picture Adjustment" menu allows you to alter the picture adjustments.

To do that: by using the menu system and after selecting the item you want to alter press , then press repeatedly  /  or  or  to adjust it and finally press **OK** to store the new adjustment.

This menu also allows you to customise the picture mode based on the programme you are watching:

• **Live** (for live broadcast programmes).

• **Movie** (for films).

• **Personal** (for individual settings).

• **Brightness, Colour and Sharpness can only be altered if "Personal" mode is selected.**

• **Hue is only available for NTSC colour signal (e.g. USA video tapes).**

• **Select Reset and press OK to reset the picture to the factory preset levels.**









GB

## Setting The Clock Manually

**ⓘ** The "Clock" option in the "Timer" menu allows you to set manually the clock whilst you are in TV mode.

To do that: by using the menu system and after selecting the option press , then :

**1** With **Auto Adjust** highlighted, press  and next press  or  to select **Off**. Next press **OK**.

**2** Select **Manual Adjust** and press . With the day column highlighted, press  or  to set the date, then press  and proceed in the same way to set the month, year, hour and minutes. Finally press **OK**.

• **It is important you to set correctly the clock to use Timer Recording, Quick-Timer recording and On Timer functions.**

• **If power is interrupted or you turn off the Video TV by using the main On/off power switch or you disconnect the AC power cord, after 7 days will cause these settings to be cleared.**

• **To automatically set the clock, and whilst you are in TV mode select "Auto Adjust" "On" in the step above and in the "Programme" option select the from which programme number you want to get the time.**

• **Because the Video TV gets clock settings from teletext signals (sent by broadcasters), even you have selected Auto Adjust "On", we recommend you to check after summertime and wintertime that clock settings are correct, if not adjust it manually.**



## Automatically Tuning The Video TV

**ⓘ** The "Auto Tuning" option in the "TV Set Up" menu allows you to automatically search for and store all available TV channels.

To do that: by using the menu system and after selecting the option, press  and then proceed in the same way as in the section "Switching On the Video TV and Automatically Tuning" (see page 6, steps 3 and 4).





## Changing The Programme Order Of The TV Channels

① The “Programme Sorting” option in the “TV Set Up” menu allows you to change the order in which the channels (TV Broadcast) appear on the screen.

To do that: by using the menu system and after selecting the option, press **▶** and then proceed in the same way as in the section “Switching On the Video TV and Automatically Tuning” (see step 5b) on page 6).



## Manually Tuning The TV

① The “Manual Programme Preset” option in the “TV Set Up” menu allows you to preset channels one by one to the programme order of your choice. To do that:

- 1 By using the menu system and after selecting the “Manual Programme Preset” option, press **▶**. Then with **Programme** option highlighted press **▶**. Press **▶** or **◀** to select on which programme number you want to preset the channel. Then press **▶**.
  - 2 After selecting the **Channel** option, press **▶**. Then press **▶** or **◀** to select the channel tuning (“C” for terrestrial channels or “S” for cable channels). Next press **▶**. After that, press the number buttons to enter directly the channel number of the TV Broadcast. If you do not know the channel number, press **▶** or **◀** to search for it. When you tune the desired channel, press **OK** twice to store.
- Repeat all the above steps to tune and store more channels.



## Fine Tuning Channels

① Normally the Automatic Fine Tuning (AFT) is operating, however by using the “Manual Programme Preset” option in the “TV Set Up” menu you can manually fine tune the Video TV to obtain a better picture reception in the case that the picture is distorted.

To do that: while watching the channel (TV Broadcast) you wish to fine tune, and by using the menu system select the “Manual Programme Preset” option. Press **▶**. With the **AFT** option highlighted, press **▶**. Next press **▶** or **◀** to adjust the fine tuning between -15 and +15. Finally press **OK** twice to store.



## Skipping Programme Positions

① The “Manual Programme Preset” option in the “TV Set Up” menu allows you to skip any unwanted programme numbers when they are selected with the PROG+/- buttons.

To do that: by using the menu system and after selecting the “Manual Programme Preset” option, press **▶**. Then with the **Programme** option highlighted press **▶**. Next, press **▶** or **◀** to select the programme number you want to skip. Press **▶**. Then, select the **Skip** option and press **▶**. Next press **▶** or **◀** to select **Yes**. Finally press **OK** twice to confirm and store.

- To cancel this function afterwards, select “No” instead of “Yes” in the step above.



## Setting Pay-TV Channels

① The “Manual Programme Preset” option in the “TV Set Up” menu allows you to watch Pay-TV channels by connecting a Pay-TV decoder to the Scart connector **1/2** placed on the rear of the Video TV.

To do that: by using the menu system and after selecting the “Manual Programme Preset” option, press **▶**. Then with the **Programme** option highlighted, press **▶**. Next press **▶** or **◀** to select the programme number with the scrambled channel and press **▶**. Select the **Decoder** option and press **▶**. Next press **▶** or **◀** to select **On**. Finally, press **OK** twice to confirm and store.

- While you are recording a programme which is being recorded through the Pay-TV decoder, you will not be able to view other programmes through the decoder.



## Selecting The Language Of The Menu Screens

① The “Language” option in the “Set Up” menu allows you to select the language that the menus are displayed in.

To do that: by using the menu system and after selecting the option, press **▶** and then proceed in the same way as in the section “Switching On the TV and Automatically Tuning” (see page 6, step 2).



## Locking The Video TV

① The “Parental Lock” option in the “Set Up” menu allows you to lock the buttons of the Video TV set. In this way, after this option is selected and the Video TV set is switched off, the buttons on the Video TV only works by using the remote control buttons.

To do that: by using the menu system and after selecting the option, press **▶**. Then press **▶** or **◀** to select **On**. Press **OK** to confirm and store and finally press **I/O**.

- To cancel this function afterwards, select “Off” instead of “On” in the step above.
- If you have locked your Video TV and the remote commander is lost, press the **I/O** button (during more than 5 seconds) on the set to operate it.



## Adjusting The Picture Rotation (only for KV-21FV1U)

① Because of the earth’s magnetism, the picture might be slant. In this case, you can correct the pictures slant by using the option “Picture Rotation” in the “Set Up” menu.

To do that: by using the menu system and after selecting the option, press **▶**. Then press **▶** or **◀** to correct any slant of the picture between -5 and +5 and finally press **OK** to store.



GB

## Switching On The Video TV Automatically (On Timer)

① The “On Timer” option in the “Timer” menu allows you to preset your Video TV to automatically switch on at a desired time. You can select the TV programme or video playback to be switched automatically on from standby mode.

To do that: by using the menu system and after selecting the option press **▶**.

- 1 With **Time** option highlighted, press **▶**. Press **▶** or **◀** to set the on-time hour then press **▶**. Proceed in the same way to set the minutes and press **OK**.
- 2 With **Source** option highlighted, press **▶**. Then press **▶** or **◀** to select the source to be switched on (“TV” or “VCR”). If you select “TV”, press **▶** and then press **▶** or **◀** to select the programme number you want the Video TV turns on. Press **OK**.
- 3 With **On Timer** option highlighted, press **▶** and then press **▶** or **◀** to select **On**. Press **OK**.
- 4 Finally press the standby button **I/O**. At the selected time, the Video TV switches on automatically.

- Any loss of power will cause these settings to be cleared.
- By pressing the **ON TIMER** button on the remote control you can set on/off the On Timer, but it is not possible to change the time and programme settings.



## Switching Off The Video TV Automatically (Sleep Timer)

① You can automatically switch the video TV into standby mode after a selected time period.

To do that: Press the **SLEEP** button on the remote control repeatedly to set the time period delay (OFF, 30, 60 or 90 minutes).

- While watching the TV, you can press the **(B) (?)** button on the remote to display the time remaining.
- One minute before the Video TV switches itself into standby mode, a good night message will be displayed on the screen.
- To cancel this function afterwards, select “Off” in the step above.



## Playing a tape

- 1 Insert a cassette with the arrow indication ▲ facing upwards.  
• If you insert a cassette with its safety tab removed, playback starts automatically.
- 2 Press **PLAY** ▶ and the playback starts. On Screen information is displayed for a few seconds.

### Additional Tasks

① You can operate all the video tasks by using the remote control buttons or the Video TV buttons.

#### To stop playback

Press **STOP** ■ and the Video TV returns to the normal TV picture.

#### To stop playback for a moment

Press **PAUSE** ⏸. Press it again or press to resume playback.

℥ If you leave your Video TV in pause mode, normal playback resumes after about 5 minutes.

#### To fast forward or rewind the tape

Press **STOP** ■, then press **FF** ▶▶ to fast forward or press **REW** ◀◀.

#### To view the picture in fast forward or rewind mode

Press and hold **FF** ▶▶ during fast forward or **REW** ◀◀ during rewind. While you hold the button, you can view the picture.

When you release the button, fast forward or rewind mode is resumed.

If you use the buttons on the remote commander, press **FF** ▶▶ or **REW** ◀◀ once and will not be necessary to hold the button. In this case to resume normal playback, press **PLAY** ▶.

#### To search a tape at high speed

During playback, press and hold **REW** ◀◀ (rewind) or **FF** ▶▶ (fast forward). A high speed picture appears on the TV screen.

℥ To resume normal playback, release the button.

#### To eject a cassette

Press **EJECT** ▲.

℥ You can eject the cassette even if the power is in standby mode.

## Protecting your cassette against accidental erasure

① To prevent accidental erasure, break off the safety tab as illustrated.

℥ To record on a cassette without a safety tab, simply cover the tab hole with adhesive tape.



or

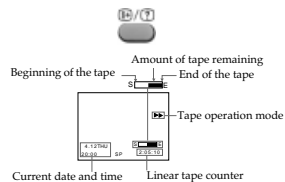
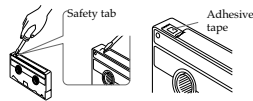
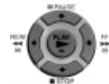

## Resetting the tape counter

① The tape counter helps you to locate a certain scene after playback.  
Press the **COUNTER RESET** button on the remote control to set the counter to "00:00:00" before playing the tape. The tape counter is automatically reset to zero whenever a cassette is inserted. The Video TV keeps counting the length of the tape being played. Note, however, that the tape counter does not count the portions without video signals recorded.

## Recording TV programmes

1 In standby mode, press the standby button I/O to turn on the Video TV.

2 Insert a cassette with a safety tab.

3 Press **PROGR** + or -, or the number buttons to select the programme number.

4 Press **TAPE SPEED** to select the recording speed: **SP** for Standard Play or **LP** for Long Play.

• In the **SP** mode, the tape runs twice as fast as the **LP** mode. It means that in **LP** mode you can record double time than in **SP** mode.

5 Press **REC** ●.

℥ The **REC** indicator on the front of the Video TV lights up and recording begins.

### To stop recording

Press **STOP** ■.

• When the tape reaches the end, the Video TV rewinds the tape automatically to the beginning, then stops.  
This function does not work when the power of the Video TV is off.

### To pause recording

① You can cut out an unwanted scene during recording with this button.

1 Press **PAUSE** ⏸ when an unwanted scene appears on the screen, then recording pauses.

2 Press **PAUSE** ⏸ again to release the pause mode at the desired scene, then recording resumes from the point set in step 1.

• When the recording pause mode lasts for about 5 minutes, the Video TV stops recording to prevent tape damage.

### Continues Recording with the TV off

① Whilst you are recording, press I/O. The Video TV is turned off. However, recording continues and the **REC** indicator on the Video TV lights up.

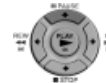
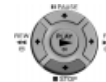

GB

## Recording TV programmes using DIAL-TIMER

**1** The Dial-Timer recording function allows you to preset your Video TV to record one programme within a 24 hour period. For setting the Dial-Timer, use DIAL TIMER button on the Video TV.

### Before you begin:

- Make sure that the clock is set correctly. If it is not, refer to the "Setting the Clock Manually" section of this instruction manual (see page 7).
- Make sure that the loaded cassette has its safety tab intact.
- Make sure that the Video TV does not enter the timer recording standby mode (the TIMER REC indicator on the Video TV should not be lit).

**1** In standby mode, press the standby button  $I/O$  to turn on the Video TV.

**2** Press **DIAL TIMER**. The "Dial Timer" menu appears on the screen.

**3** Turn **DIAL TIMER** to set the hour of the start time, then press **DIAL TIMER** to confirm.

**4** Proceed in the same way as in step 3 to set the minutes of the recording start time, the recording time period and programme number to be recorded.

- The hour increases or decreases by one hour.
- The minutes increase or decrease by one minute.
- The recording time period increases or decreases by 15 minutes.
- The programme position changes as follows:

0 <-> 1 <-> 2... <-> 99 <-> L1 <-> L2 <-> 0 <-> 1

- L1 is used for the equipment connected to the Scart connector  $\text{G}/1/\text{---}$  placed on the rear of the Video TV.
- L2 is used for the equipment connected to the front connectors  $\text{---}$  and  $\text{---}$ .

**5** With **TAPE SPEED** highlighted, turn the **DIAL TIMER** to select the recording speed: **SP** for Standard Play or **LP** for Long Play, then press the **DIAL TIMER**.

- In **LP mode** you can record double time than in **SP mode**.

**6** Turn **DIAL TIMER** to move the cursor to **OK**, then press **DIAL TIMER** to confirm all the settings.

- If a warning message appear on the screen, the recording is cancelled and after proceed according the necessities, you must re-enter again the Dial timer settings.

The Dial timer indicator on the Video TV lights up and the Video TV enters into the timer recording standby mode.

## Changing or Cancelling the Dial Timer settings

**1** Press **DIAL TIMER**.  
The Dial Timer menu appears on the screen.

**2** Turn **DIAL TIMER** to **CHANGE** (to change the recording settings) or to **CLEAR** (to clear the recording settings) and press **DIAL TIMER**.

- 3** a) If you have selected **CLEAR**, press **DIAL TIMER** and all the settings will be cleared.  
b) If you have selected **CHANGE**, you can change all the settings by following steps from 2 to 5 of the above section "Recording TV Programmes using DIAL TIMER".

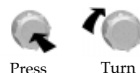
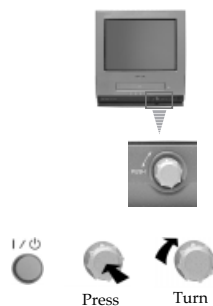

## Recording TV Programmes Using the Timer

**1** This function allows you to preset your Video TV to record up to 5 programmes within a one-month period.

### Before you begin:

- Make sure that the clock is set correctly. If it is not, please refer to the section "Setting the Clock Manually" (see page 7).
- Make sure that the loaded cassette has its safety tab intact.

### Setting the Timer

**1** In standby mode, press the standby button  $I/O$  to turn on the Video TV.

**2** Press the **TIMER REC** button to display the Programme List menu.

**3** Press  $\blacktriangle$  or  $\blacktriangleright$  repeatedly to set the date (for daily and weekly recording, refer to the section "Daily/Weekly Recording" below), then press  $\blacktriangle$ .

**4** Proceed in the same way as in step 3 to set recording start time, recording stop time, programme number, tape speed (SP or LP) and VPS/PDC "On" or "Off".

**1** If you have made a mistake during timer setting, press  $\blacktriangle$  to return to the previous position and correct the setting.

#### • Date:

##### Daily/Weekly Recording

You can preset your Video TV to record the same programme every day of the week (daily recording) or the same programme on the same day every week (weekly recording).

Whilst you are in DATE position, with each press of  $\blacktriangle$ , the setting changes as follows:

23 SAT (today)  $\rightarrow$  MON-SUN  $\rightarrow$  MON-SAT  $\rightarrow$  MON-FRI  $\rightarrow$  SAT (means every Saturday...)  $\rightarrow$  FRI  $\rightarrow$  SUN  $\rightarrow$  22 (next month)... $\rightarrow$

#### • Time:

- The hour increases or decreases by one hour.
- The minutes increase or decrease by one minute.

#### • Programme number:

- The programme position changes as follows:  
0 <-> 1 <-> 2... <-> 99 <-> L1 <-> L2 <-> 0 <-> 1

- L1 is used for the equipment connected to the Scart connector  $\text{G}/1/\text{---}$  placed on the rear of the Video TV.

- L2 is used for the equipment connected to the front connectors  $\text{---}$  and  $\text{---}$ .

#### • Tape Speed:

- In "LP" mode you can record double than in SP mode

#### • VPS/PDC:

- For details refer to "Timer recording with VPS/PDC signals" section of this instruction manual (see page 14).

**5** Press **OK**.

**6** If you want to set more programmes, press  $\blacktriangle$  or  $\blacktriangleright$  to move the cursor to **ADD** and then press **OK**. Repeat steps from 3 to 5.

**7** After setting all your desired programmes press  $\blacktriangle$  or  $\blacktriangleright$  and highlighting **OK**, press the **OK** button to confirm your settings.

The **TIMER REC** indicator on the Video TV lights up and the Video TV enters into timer recording standby mode.

## To Stop Timer Recording

Press the **ON/OFF** button on the remote control. Then the **TIMER REC** indicator on the Video TV turns off.

## Using the Video TV before Timer Recording starts

**1** You can watch a TV programme, check the timer settings and reset the counter in timer recording standby mode. However, if you want to eject the cassette, use the tape operation buttons, change or cancel the timer settings, you have to press the **ON/OFF** button on the remote control to turn off the **TIMER REC** indicator on the Video TV set.

**A** Remember to press again the **ON/OFF** button to make the **TIMER REC** indicator lights up again and the set comes back into the timer recording standby mode.

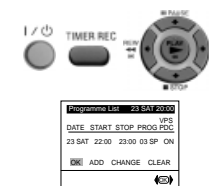

GB

## Timer recording with VPS/PDC signals

Some broadcasting system transmits VPS (Video Programme System) signals or PDC (Programme Delivery Control) signals with the TV programmes. These signals assure you that your timer recordings are made regardless of broadcast delays, early starts, or broadcast interruptions. For example, if an urgent news bulletin interrupts a regular programme, recording stops. As soon as the interrupted programme resumes, recording starts again. To do that:

1 When you set a programme to be recorded by using the timer, (refer to the "Setting the Timer" section on page 13), set **VPS/PDC to On**.

- If recording times overlap due to a VPS/PDC time shift, the programme that was broadcast first has priority. Recording of the second programme begins when the first programme has finished.
- If the Video TV could not receive VPS/PDC signal because it was too weak or because the station failed to transmit VPS/PDC signals, timer recording is made without the VPS/PDC function.

## Recording TV Programmes Using VideoPlus+ \*

\* VideoPlus+ is a trademark applied for by Gemstar Development Corp. VideoPlus+ system is manufactured under license from Gemstar Development Corporation.

The VideoPlus+ function allows you to simplify the task of making timer recordings. Using VideoPlus+, you can make all the necessary settings by just entering the desired programme's 9-digit code, which is available in your local programme guide.

Before you begin:

- Make sure that the loaded cassette has its safety tab.

1 In standby mode, press the standby button  $\text{I/O}$  to turn on the Video TV.

2 Press the **VIDEOPLUS+** button to display the VideoPlus+ menu.

3 Press the number buttons to enter the desired programme's VideoPlus+ number and press **OK**.

- If you have made a mistake, press  $\blacktriangleleft$  and re-enter the correct number.

4 On the screen appears automatically date and time recording settings. With **PROG** column highlighted, press  $\blacktriangleright$  or  $\blacktriangleleft$  to select the correct programme number and then press  $\blacktriangleright$ .

5 Press  $\blacktriangleright$  or  $\blacktriangleleft$  to select the recording speed: **SP** or **LP**. Then press  $\blacktriangleright$ .

- In LP mode you can record double time than in SP mode.

6 Highlighting the **VPS/PDC** column, press  $\blacktriangleright$  or  $\blacktriangleleft$  to select **On** or **Off**. (for details, refer to "Timer recording with VPS/PDC signals" section above). Then press  $\blacktriangleright$ .

7 The Programme List menu appears on the screen. If recording settings are correct, highlighting **OK**, press the **OK** button to confirm.

8 If you want to check, add, change or cancel your settings please refer to the "Checking/ Adding/ Changing/ Cancelling the Timer Settings" section (see page 15).

The **TIMER REC** indicator on the front of the Video TV lights up and the set enters into timer recording standby mode.

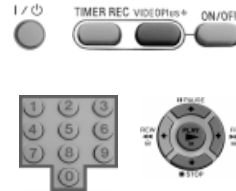

## Guide Channels for VideoPlus+

Guide channel	Station name	Guide channel	Station name
001	BBC1	123	UK GOLD
002	BBC2	124	DISCOVERY
003	ITV		THE LEARNING CHANNEL
004	CHANNEL 4	125	BRAVO
005	RTE (IRELAND)		ADULT CHANNEL
006	NETWORK 2 (IRELAND)	126	CNN
101	SKY ONE	127	EURONEWS
102	SKY NEWS	129	OVC
103	SKY MOVIES	130	UK LIVING
104	THE MOVIE CHANNEL		TV-X
105	SKY SPORT	131	RAI 1
106	NICKELODEON	132	RAI 2
	VH-1 GERMANY	133	TV5 EUROPE
107	EUROSPORT	134	TVE INTERNATIONAL
108	GALAVISION	135	MBC / ARABIC
109	MTV EUROPE	136	VTM
110	CHILDREN'S CHANNEL	137	SPORTNET
	THE FAMILY CHANNEL	138	COUNTRY MUSIC TV
111	SKY MOVIES GOLD	139	VIDEO HITS ONE
112	BBC WORLD SERVICE		VH-1
113	RTL 4	140	SKY SPORT 2 &
114	SUPER SPORT		SOAPS & TRAVEL
	FILMNET 2	141	TV ASIA
	FILMNET +	142	LA-5
115	RTL PLUS INTERNATIONAL	143	LIVE TV
116	SAT 1	144	SUPERCHANNEL
117	PREMIERE	145	JAPAN TV
118	3 SAT	146	SELECT TV
119	ARD	147	MOVIE CHANNEL
120	PRO 7		FILMNET 1
121	TELE 5	148	SKY SPORT 3
122	TELECLUB	149	TNT
			CARTOON NETWORK

## Checking/Adding/Changing/Cancelling the Timer Settings

1 Press the **TIMER REC** button on the remote control to display the list of the timer settings that you preset. If you just want to check the list, go to step 4. If you want to add, change or clear any setting, please follow all the steps below.

2 Press  $\blacktriangleright$  or  $\blacktriangleleft$  repeatedly to select **ADD**, **CHANGE** or **CLEAR** and press **OK**.

3 a) To add new settings:

Repeat steps from 3 to 7 of the section "Setting the Timer" (see page 13).

b) To change the settings:

Press  $\blacktriangleright$  or  $\blacktriangleleft$  repeatedly to move the cursor to the setting you want to change, then press **OK**. Finally repeat steps from 3 to 7 of the section "Setting the Timer" (see page 13).

ⓘ If you notice you have overlapped timer settings, you can correct the settings as mentioned above. Otherwise, the second programme starts recording only after the first programme has finished.

c) To clear the settings:

Press  $\blacktriangleright$  or  $\blacktriangleleft$  repeatedly to move the cursor to the setting you want to delete, then press **OK**. The setting is cleared and "--" appears.

4 When you finish adding, changing or cancelling the settings, press  $\blacktriangleright$  or  $\blacktriangleleft$  to select **OK** and then press the **OK** button.

ⓘ If there are other timer setting on the list, the Video TV enters the timer recording standby mode and the **TIMER REC** indicator on the Video TV set lights up.

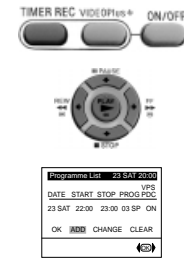

GB

## Playing a Tape Repeatedly

① The “Auto Repeat” option in the “VCR Set Up” menu allows you to play a recorded tape repeatedly.

To do that: by using the menu system and after selecting the option, press **▶**. Then press **◀** or **▶** to select **On**. Finally press **▶** to start the playback. When the tape reaches its end, the video TV rewinds the tape to the beginning and then, plays it again.

- To cancel this function afterwards, select “Off” instead of “On” in the step above.



## Searching Using the Index Function

① The Video TV marks the tape with an index signal at the point where each recording begins. These signals can be used to find a specific recording, this Video TV can search up to 99 index signals ahead of or behind the current position.

To do that:

- 1 Insert a tape.
- 2 Press **INDEX** **◀** or **▶** repeatedly to specify how many index signals ahead or behind you want to search in relation to the current tape position. The Video TV begins searching for the selected index. When the index is reached, playback begins automatically.

- You can stop searching by pressing **STOP**.



## Adjusting the Tracking

① The tracking condition is automatically adjusted on this Video TV. The AUTO TRACKING message appears while the Video TV is searching for the best tracking condition.

However, if streak or snow noise appear on the video playback, you can adjust the tracking condition manually by using the “Tracking Control” menu in the “VCR Set Up” menu.

To do that: Whilst you are in play mode and by using the menu system, select the **Tracking Control** menu and press **▶**. Press **◀** or **▶** to select **Manual** and press **▶**. When the tracking meter appears on the screen press **◀** or **▶** to reduce the picture noise and get the best picture noise. Finally press **OK**.

- To cancel this function afterwards, select again “Auto” instead of “Manual” in the step above.

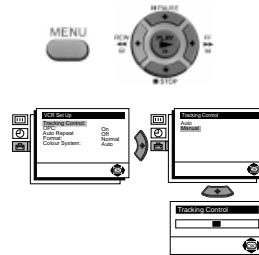

## Adjusting the Picture with the Optimum Picture Control (OPC)

① The “OPC” option in the “VCR Set Up” menu allows you to improve playback and recording quality by adjusting the system parameter automatically according to the condition of the video tape. The OPC function works on all types of tapes, even on rental tapes. This function is set to “On” at the factory. To maintain better picture quality, we recommend to leave the function on.

To do that: Whilst you are in play mode and by using the menu system, select the **OPC** option and press **▶**. Then press **◀** or **▶** to select **On** or **Off**. Finally press **OK**.



## Setting the Colour System

① The colour system is set in “Auto” condition. However, by using the “Colour System Option” in the “VCR Set Up” menu allows you to, set the colour system to the corresponding system that the tape was recorded in the case that you notice streaks appearing on the screen during playback

To do that: Whilst you are in play mode and by using the menu system, select the **Colour System** option and press **▶**. Then press **◀** or **▶** to select the corresponding colour system (**Auto**, **MESECAM**, **PAL** or **NTSC**). Finally, press **OK**.

- To cancel this function afterwards, select again “Auto” in the step above.

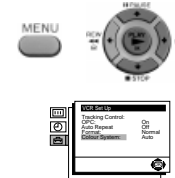

## Viewing Programmes in 16:9 Mode

① When viewing recording of programmes which were originally broadcast in 16:9 mode, you can set your Video TV to 16:9 mode to prevent a distorted picture.

To do that: Press repeatedly the button **16:9** on the remote control to select 16:9 or Normal (4:3 format). You can also do it, by using the menu system. In that case, select the **Format** option in the “VCR Set Up” menu and press **▶**. Then press **◀** or **▶** to select **16:9** or **Normal**. Finally, press **OK**.

- When you change channels, switch between input sources or turn the power on and off, the Video TV will switch back to normal mode.

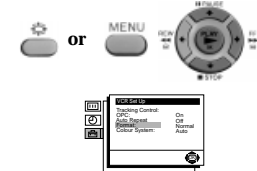

GB

## When Connecting to a Sony VCR

① If you use this Video TV with another Sony VCR, the remote control may accidentally operate both the Video TV and VCR at the same time. The **VHS** option in the “Set Up” menu allows you that the remote control operates only this Video TV.

To do that: by using the menu system and after selecting the **VHS** option, press **▶**. Then press **◀** or **▶** to select **Sony**. Finally, press **OK**.

- To cancel this function afterwards, select “Others” in the step above.



## Teletext

**i** Teletext is an information service transmitted by most TV stations. The index page of the teletext service (usually page 100) gives you information on how to use the service. To operate teletext, use the remote control buttons as indicated below.

**A** Make sure to use a channel (TV Broadcast) with a strong signal, otherwise teletext errors may occur.

### To Switch On Teletext:

After select the channel (TV Broadcast) which carries the teletext you wish to view, press .

### To Select a Teletext page:

Input 3 digits for the page number, using the numbered buttons.

- If you have made a mistake, retype the correct page number.
- If the counter on the screen continues searching, it is because this page is not available. In that case, input another page number.



### To access the next or preceding page:

Press PROGR + () or PROGR - (.



### To superimpose teletext on to the TV:

Whilst you are viewing teletext, press . Press it again to cancel teletext mode.

### To freeze a teletext page:

Some teletext pages have sub-pages which follow on automatically. To stop them, press  / . Press it again to cancel the freeze.

### To reveal concealed information (e.g. answer to a quiz):

Press  / . Press it again to conceal the information.

### To Switch Off Teletext:

Press .

## Fastext

**i** Fastext service lets you access pages with one button push.

While you are in Teletext mode and Fastext is broadcast, a colour coded menu appears at the bottom of the teletext page. Press the colour button (red, green, yellow or blue) to access the corresponding page.

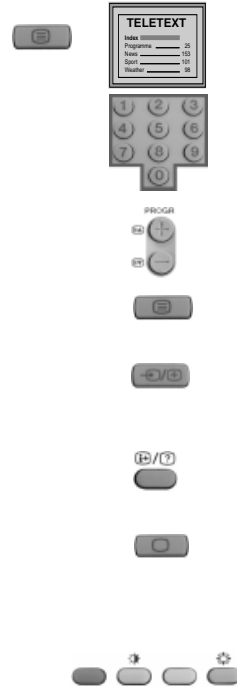

## Connecting Optional Equipment



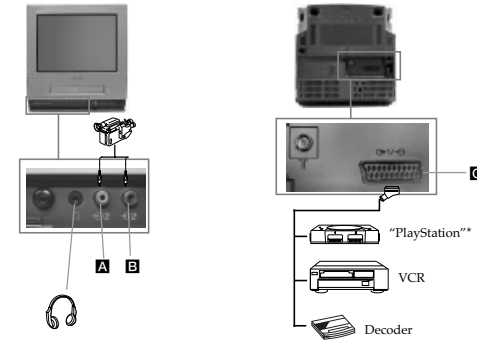

**i** Using the following instructions, you can connect a wide range of optional equipment to your Video TV set. (Connecting cables are not supplied).



\* "PlayStation" is a product of Sony Computer Entertainment, Inc.  
\* "PlayStation" is a trademark of Sony Computer Entertainment, Inc.



GB

## Using Optional Equipment

**i** In order to get the input signal of a connected equipment onto the TV screen, you need to select the symbol of the connector to which you have connected the device.  
e.g.: You have connected a "PlayStation" to the connector with the symbol  / . Press the button  on the remote control repeatedly until you see the symbol  on the screen.

- 1 Connect your equipment to the designated Video TV socket, as indicated above.
- 2 To watch the picture of the connected equipment, press the  button repeatedly until the correct input symbol appears on the screen.

### Symbol Input Signals

- |   |   |
|---|---|
|  | • Audio / video input signal through the Scart connector <b>C</b> .               |
|  | • RGB input signal through the Scart connector <b>C</b> .                         |
|  | • Video and audio input signals through the phono sockets <b>A</b> and <b>B</b> . |

- 3 Switch on the connected equipment.
- 4 Press  button on the remote control to return to the normal TV picture.

## Editing with another VCR

**i** Using an additional VCR and connecting as it is in the section above "Connecting Optional Equipment", you can edit a tape.

## Video Head Cleaning

**i** Even the Auto Head Cleaner built into this set automatically cleans the video heads when a cassette is loaded or unloaded. However, if the playback pictures are noisy and hardly visible or no picture appears, video heads probably need an extra cleaning. In this case, clean the video heads using the V-25CL video head cleaning tape (not supplied) or ask Sony service personnel to clean the video heads.

**A** Do not use a commercially available wet-type cleaning tape, as it may damage the video heads.

### Symptoms caused by contaminated video heads

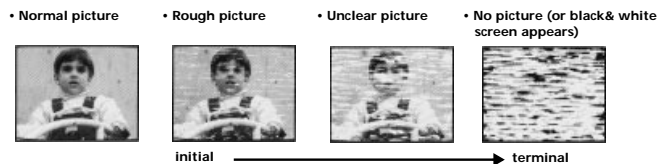

## Worn Video heads

**i** If your Video TV displays a poor picture after you clean the video heads, you may need to replace them. Consult your dealer or the Sony Service Centre nearest you.

## Check the video heads after 1,000 hours of use

**i** A Video TV is a high precision machine. It must record on or play from magnetic tapes on which the image signals from the colour TV or the video camcorder are recorded. The video heads or mechanical parts for transporting the tape are contaminated or worn after extended use. You should have your Video TV checked after each 1,000 hours of use.

## Troubleshooting

**i** If you have any problems while viewing your Video TV, please check the following troubleshooting guide. If the problem persists, contact your Sony dealer.

Problem	Solution
<b>TV Section</b>	
No picture (screen is dark) and no sound.	<ul style="list-style-type: none"> <li>Check the aerial connection.</li> <li>Plug the Video TV in and press the <b>⏻</b> button on the front of TV or if the standby indicator <b>I/O</b> is on, press <b>I/O</b> button.</li> </ul>
Poor or no picture (screen is dark), but good sound.	<ul style="list-style-type: none"> <li>Using the menu system, select the "Picture Adjustment" menu and select "Reset" to return to the factory settings.</li> </ul>
No picture when watching equipment connected to the Scart connector.	<ul style="list-style-type: none"> <li>Check that the optional equipment is on and press the <b>⏻</b> button repeatedly on the remote control until the correct input symbol is displayed on the screen.</li> </ul>
Good picture, no sound.	<ul style="list-style-type: none"> <li>Press the <b>⏻ +/-</b> button on the remote control.</li> </ul>
No colour on colour programmes.	<ul style="list-style-type: none"> <li>Using the menu system, select the "Picture Adjustment" menu and select "Reset" to return to factory settings.</li> </ul>
Distorted picture when changing programmes or selecting teletext.	<ul style="list-style-type: none"> <li>Turn off any equipment connected to the Scart connector on the rear of the TV.</li> </ul>
Picture slanted (only for KV-21FV1U).	<ul style="list-style-type: none"> <li>Using the menu system, select the "Picture Rotation" option in the "Set Up" menu to correct the picture slant.</li> </ul>
Noisy picture when viewing a TV channel.	<ul style="list-style-type: none"> <li>Using the menu system, select the "Manual Programme Preset" menu and adjust Fine Tuning (AFT) to obtain better picture reception.</li> </ul>
<b>Clock section</b>	
The clock has stopped and "--:--" is displayed.	<ul style="list-style-type: none"> <li>Reset the clock and timer settings. For details refer to the section "Setting the Clock Manually" (see page 7).</li> </ul>
<b>Playback section</b>	
Power is on, but the tape does not run.	<ul style="list-style-type: none"> <li>Switch off, disconnect the AC power cord and leave the set for about one minute.</li> </ul>
Poor playback picture.	<ul style="list-style-type: none"> <li>Using the menu system, select the "VCR Set Up" menu and check the "Colour System" option.</li> <li>Adjust the tracking manually. For details refer to the section "Adjusting the Tracking" (see page 16).</li> <li>Clean the video heads. For details refer to the section "Video Head Cleaning" (see page 20).</li> <li>Use a new tape.</li> </ul>
The sound drops out.	<ul style="list-style-type: none"> <li>Use a new tape.</li> </ul>
<b>Recording section</b>	
The cassette is ejected when you press REC ●.	<ul style="list-style-type: none"> <li>Cover the safety tab hole. For details refer to the section "Protecting your cassette against accidental erasure" (see page 10).</li> </ul>
Cannot record.	<ul style="list-style-type: none"> <li>Insert a cassette with its safety tab intact.</li> <li>Rewind the tape.</li> </ul>
<b>Timer recording section</b>	
Cannot program a recording using the timer.	<ul style="list-style-type: none"> <li>Set the current time and date. For details refer to the section "Setting Clock Manually" (see page 7).</li> </ul>
The cassette is ejected when you press TIMER REC ON/OFF.	<ul style="list-style-type: none"> <li>Cover the safety tab hole. For details refer to the section "Protecting your cassette against accidental erasure" (see page 10).</li> </ul>
The TIMER REC indicator on the front of the Video TV does not light up even though you press TIMER REC ON/OFF.	<ul style="list-style-type: none"> <li>Insert a cassette with its safety tab intact.</li> <li>Rewind the tape.</li> <li>Check the settings for timer recording. For details refer to the section "Checking/Adding/Changing/Canceling the Timer Settings" (see page 15).</li> </ul>
<b>Others</b>	
A cassette cannot be inserted.	<ul style="list-style-type: none"> <li>Press EJECT ▲ to eject the cassette that it is already inserted.</li> </ul>
Remote control does not function.	<ul style="list-style-type: none"> <li>Replace the batteries.</li> </ul>
The standby indicator <b>I/O</b> on the Video TV flashes.	<ul style="list-style-type: none"> <li>Contact to your nearest Sony service centre.</li> </ul>

**A** In case of problems, have your TV serviced by qualified personnel. Never open the casing yourself.

## SECTION 2 DISASSEMBLY

### 2-1. REAR COVER REMOVAL

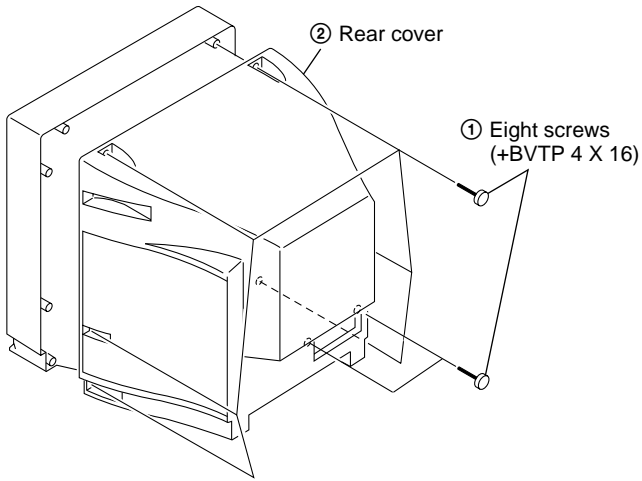

### 2-2. CHASSIS ASSY REMOVAL

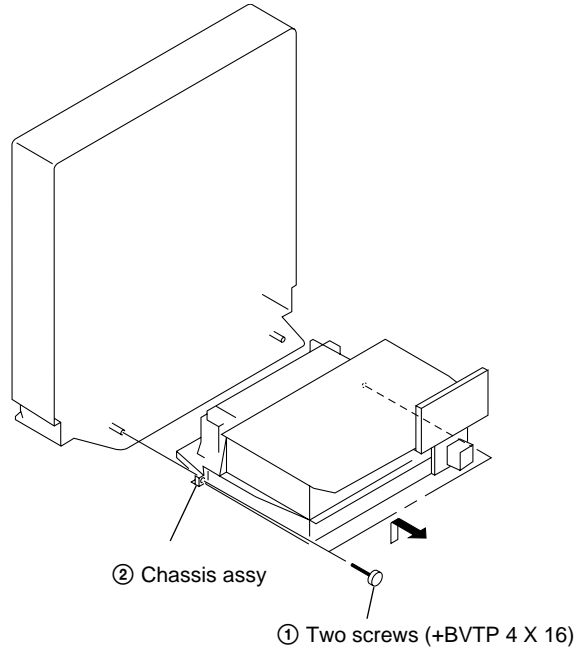

### 2-3. SERVICE POSITION (A BOARD)

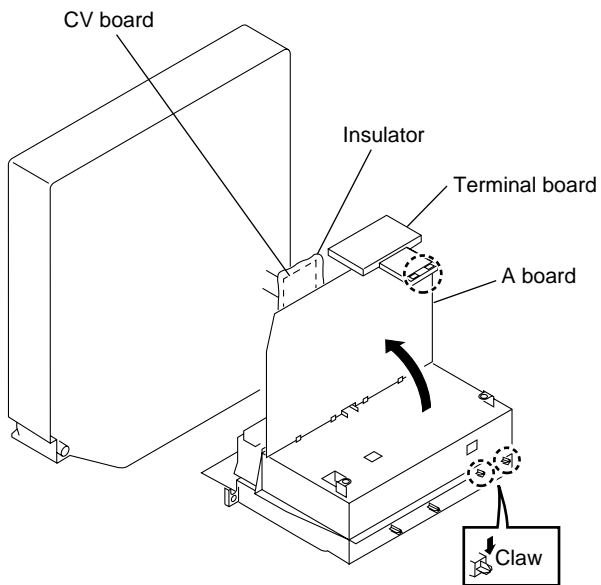

### 2-4. A BOARD REMOVAL

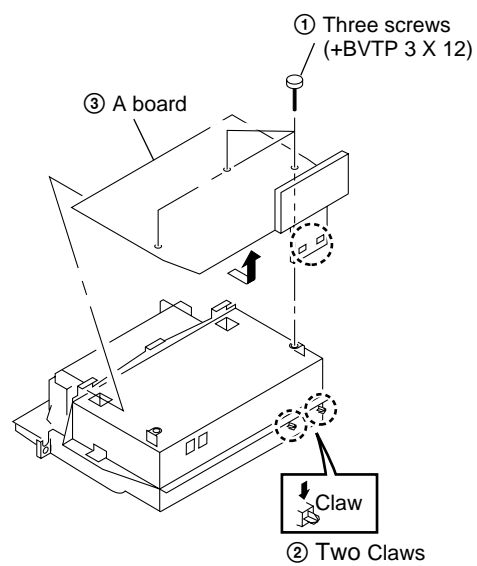

**Note:** Open the A board after slide the terminal board



## 2-5. HARNESS LOCATION

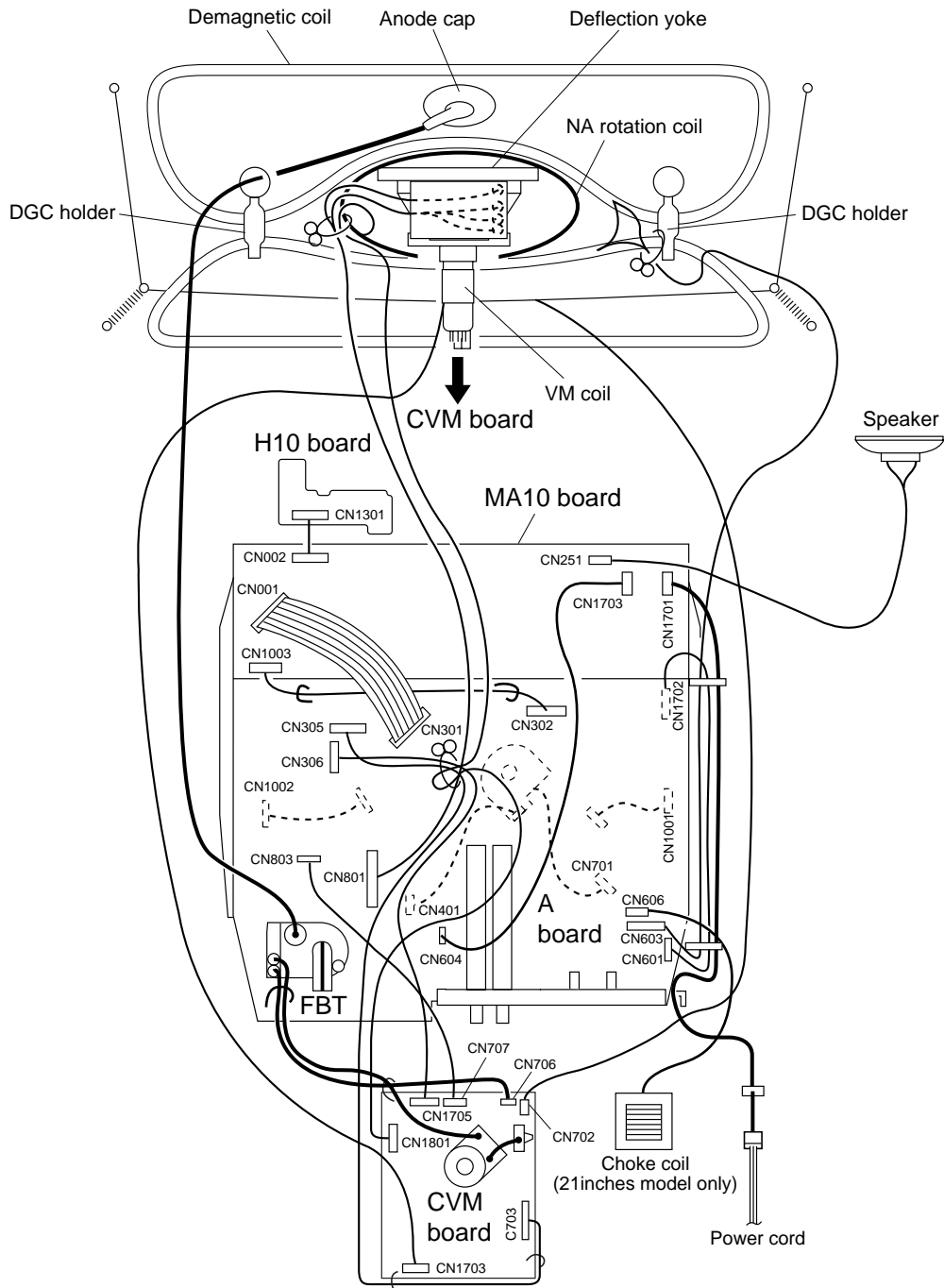

## 2-6. PICTURE TUBE REMOVAL

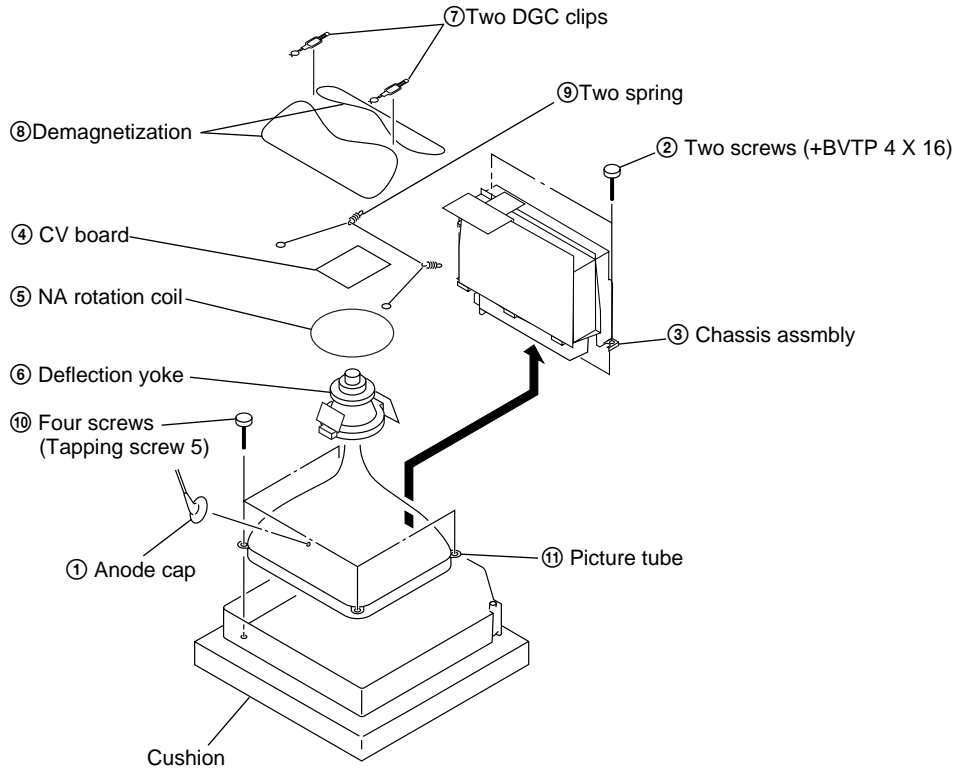

### • Removal of anode-cap

NOTE : Short circuit the anode of the picture tube and the anode cap to the metal chassis, CRT shield or carbon paint on the CRT, after removing the anode.

### • removing procedures

- ① Turn up one side of the rubber cap in the direction indicated by the arrow (a).

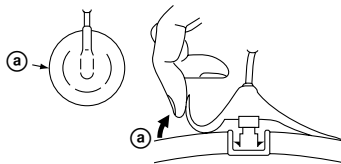

- ② Using a thumb pull up the rubber cap firmly in the direction indicated by the arrow (b).

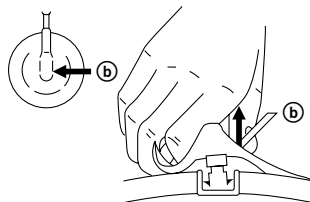

- ③ When one side of the rubber cap is separated from the anode button, the anode-cap can be removed by turning up the rubber cap and pulling it up in the direction of the arrow (c).

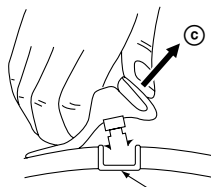

### • how to handle an anode-cap

- ① Don't hurt the surface of anode-caps with shaped objects!
- ② Don't press the rubber too hard so as not to hurt inside of anode-caps!  
A metal fitting called the shatter-hook terminal is built into the rubber.
- ③ Don't turn the foot of rubber over too hard!  
The shatter-hook terminal will stick out of damage the rubber.

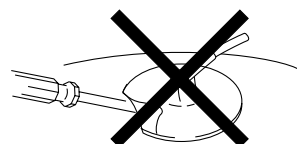
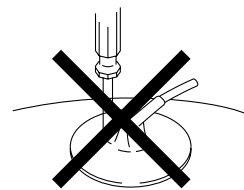

## SECTION 3 SET-UP ADJUSTMENTS

- The following adjustments should be made when a complete realignment is required or a new picture tube is installed.
- These adjustments should be performed with the rated power supply voltage, unless otherwise noted.

The PICTURE and Brightness controls should be set as follows unless otherwise noted:

CONTRAST .....	100% (LIVE)
BRIGHTNESS control .....	50%
COLOUR .....	50%
HUE .....	50%
SHARPNESS .....	50%

Perform the adjustments in the following order:

1. Beam Landing
2. Convergence
3. Focus
4. Screen (G2)
5. White Balance
6. Picture Distortion

**Note:** Test Equipment Required.

1. Color bar/Pattern Generator
2. Degausser
3. Oscilloscope

### Preparation:

- In order to reduce the influence of external magnetic forces on the picture tube, face the TV set in an easterly or westerly direction.
- Turn the power switch for the unit ON and erase the magnetic force using a degausser.

### 3-1. BEAM LANDING

1. Degauss CRT screen.
2. Input all-green pattern.
3. Adjust roughly landing at the centre of the screen by moving the purity magnet.
4. Adjust roughly landing at both right and left sides of the screen by sliding the DY forward or backward.
5. Adjust landing according to the lupe method or the allowance method.
6. Adjust DY so the horizontal tilt of DY is within the standard. Product standard is as follows.

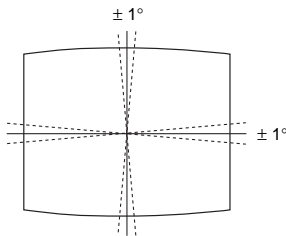

7. Use disk magnet, if landing at the corner is not good. Disk mag should be applied on the funnel. Don't use mag if possible because of picture distortion.
8. Screw down the DY.

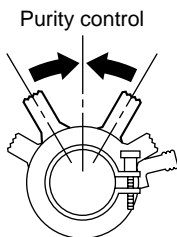

Fig.3-1

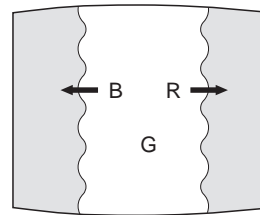

Fig.3-2

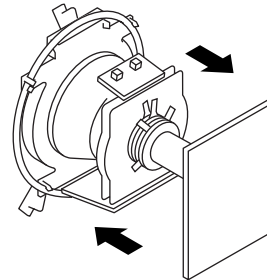

Fig.3-3

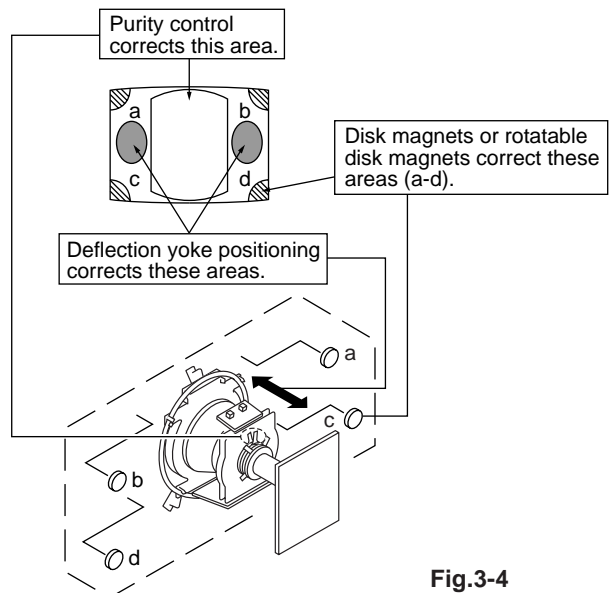
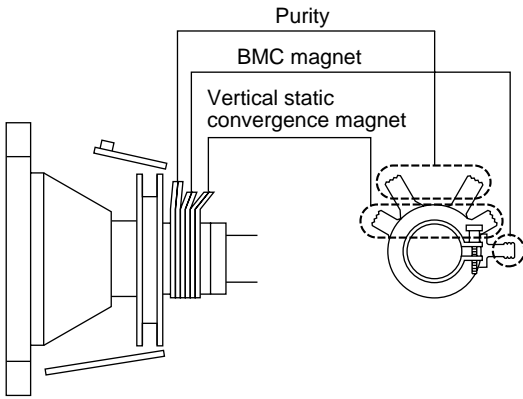

Fig.3-4

### 3-2. CONVERGENCE



#### (1) Horizontal and Vertical Static Convergence

1. Receive the channel with dot signal.
2. Minimize BRT and set picture level to the position where the dot is easy to see.
3. Adjust horizontal convergence at the centre of the screen with V. STAT correction piece.
4. Adjust vertical convergence of dot at the centre of the screen with V. STAT MG.
5. Adjust repeatedly static convergence according to right figure in case that both HMC and VMC are not independent.

In case that both HMC and VMC exist attach BMC magnet to neck assembly.

Case of HMC attached

Turn BMC over in case of adjustment in opposite direction.

Use BMC mg only when it is necessary, for it makes CRT focus worse.

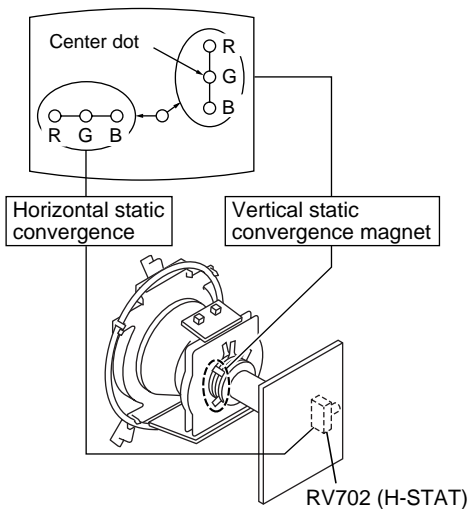
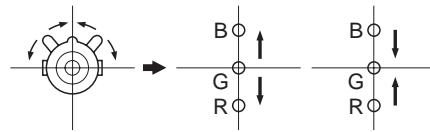

Fig.3-5

- Movement of red, green and blue dots by V. STAT tilting and opening or closing.

- ① Movement of opening or closing the V. STAT convergence magnet.



- ② Movement of tilting the V. STAT convergence magnet counterclockwise.

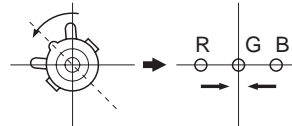

- ③ Movement of tilting the V. STAT convergence magnet clockwise.

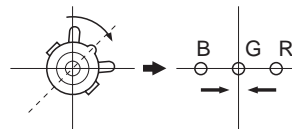

- ④ Movement of tilting and opening or closing the V. STAT convergence magnet.

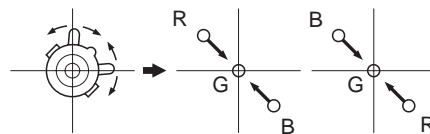

- If the blue dot did not harmonize with red and green, then use the BMC magnet to adjust.

- 1) HMC (Horizontal mis-convergence) correction

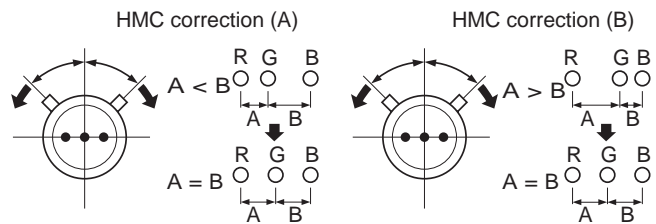

- 2) VMC (Vertical mis-convergence) correction.

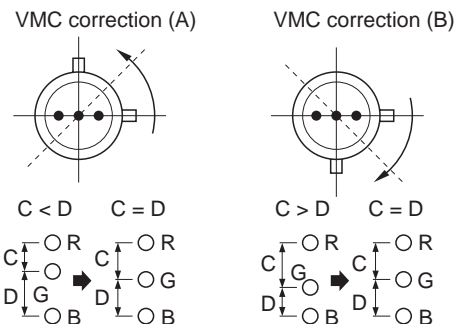

## (2) Convergence adjustment of screen surroundings.

(Dynamic convergence)

1. Receive dot pattern.
2. Set BRT to main and PIC to the level where dot pattern is easy to see.
3. Shake DY up and down. Insert DY spacer at position 'A' so that cross MIS convergence is minimum.
4. Shake DY right or left and insert DY spacer at position 'C' and 'D' where tilt is the smallest both on vertical and horizontal axis.

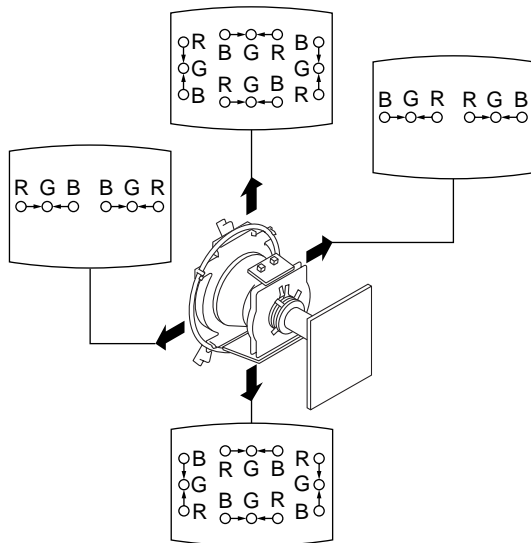

Fig.3-6

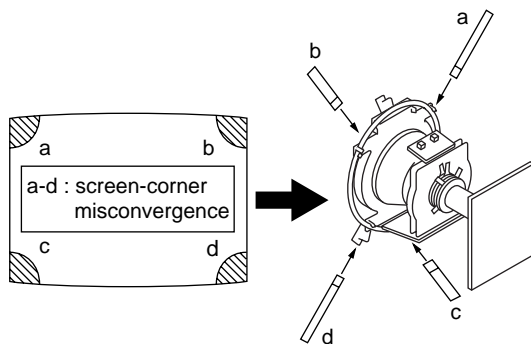

Fig.3-7

## 3-3. FOCUS ADJUSTMENT

1. Receive monoscope pattern.
2. Adjust FBT focus VR so that the picture has the best focus.  
Adjust the focus so that the center of the screen is in the best focus.  
Turn focus VR clockwise to the end and then turn back counter clockwise.  
While turning back, pay attention to the centre cross of the colour pattern, and then adjust the VR so that horizontal line because clear and vertical line begins to become unclear.  
Change signal to dot pattern, confirm that corner focus is good.
3. Receiving white signal, confirm that magenta ring is hardly noticed.

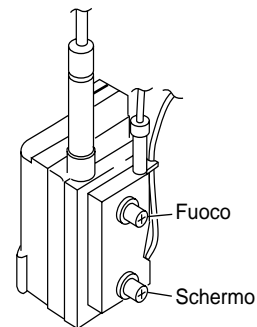

Fig.3-8

## 3-4. SCREEN (G2) ADJUSTMENT

1. Receive a Black signal, Cross and Hatch signal or dots signal.
2. Make sure to be in Personal, reset condition.
3. Adjust screen VR on FBT so that highest level of black area among cathodes is  $175 \pm 2$  V.

### 3-5. WHITE BALANCE ADJUSTMENT

1. Input white pattern. Adjust white balance of drive side, using service mode VP No. 22 RAMP, No. 23 GAMP and No. 24 BAMP, so that colour temperature is 8600 K + 0 MPCD.
2. Input gray pattern for 10NIT. Adjust white balance of cut-off side, using service mode No. 25 RCUT, No. 26 GCUT and No. 27 BCUT, so that colour temperature is 8600 K + 0 MPCD.
3. To take tracking, confirm again that colour temperatures of both side are within the limit of the above standard 8600 K + 0 MPCD. If necessary, re-adjust.

W/B Specification:

H/L difference = 2JND or less

C/O difference = 3JND or less

### 3-6. PICTURE DISTORTION ADJUSTMENT

- When performing these adjustment, do receive monoscope signal.

VP01 (HSIZ)

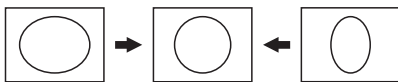

VP02 (HPOS)

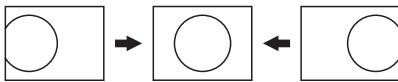

VP03 (VSIZ)

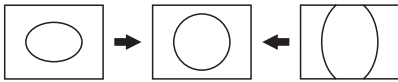

VP04 (LCPN)

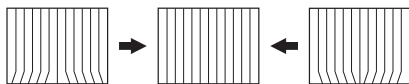

VP05 (UCPN)

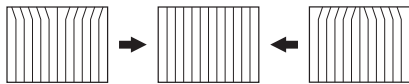

VP06 (AFAG)

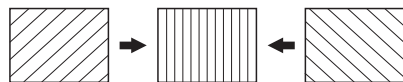

VP07 (AFBW)

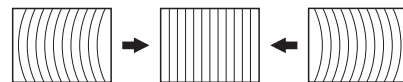

VP08 (PAMP)

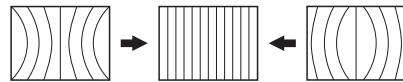

VP09 (VPOS)

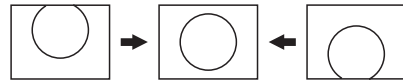

VP10 (VLIN)



VP11 (SCOR)

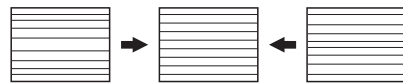

VP13 (TRAP)

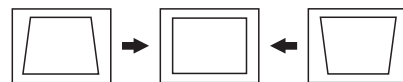

# SECTION 4

## CIRCUIT ADJUSTMENTS

### 4-1. ADJUSTMENTS WITH COMMANDER

#### 1. ENTERING SERVICE MODE

- 1) Turn on the main power of the set and enter into stand-by mode.
- 2) Press the following sequence of buttons on the Remote Control Commander.

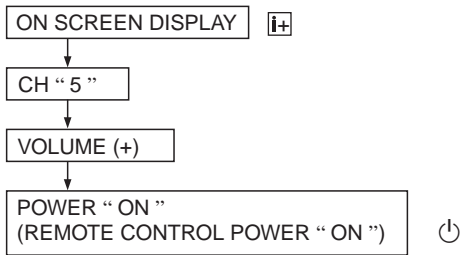

#### 2. TO READ THE MEMORY

- 1) Set to service mode.
- 2) When push these buttons 7 → 0 on the remote commander, it would read all item's adjustment value and switch set-up value which written in the memory.

**Note:** Do not read before "standard value" writing when exchange the MEMORY IC002.

#### 3. PICTURE ADJUSTMENT

- 1) Select adjustment item number of service mode by 1 and 4 buttons on the remote commander.
- 2) Adjust 3 and 6 buttons to satisfy set-up value and picture condition of the screen.

#### 4. WRITE TO THE MEMORY

- After adjusted, write to the MEMORY by MUTE and 0 buttons and push 0 button while green "light" word indicated on the picture display (about 3 seconds). It takes about 1 second to complete the writing to the MEMORY. When red "light" displayed turns to "G" and that makes writing completely finish.

Color of the screen displayed light word.

MUTE button on ..... Green word

0 button on ..... Red word

#### 5. RELEASE THE SERVICE MODE

- Turn off TV set and turn on again or turn off by the remote commander, and turn off by the remote commander again by stand-by state to disappear service display and set to normal TV mode.

#### 6. WRITING "STANDARD VALUE"

- 1) Set to service mode.
- 2) When push 5 button on the remote commander green colored "INITIAL write" indicates on the screen right above. Continuing to press 0 button while words are displaying (about 3 seconds). Display turns to red colored "INITIAL write" then the screen become pitch-dark and select 1ch about 5 seconds after. Then it turns green colored "G" display.

Perform writing "standard value" standard data in micro computer will write to the MEMORY and set to initialization state all.

**Note:** When exchange only MEMORY IC002, perform "standard value" writing in the beginning.

## 4-2. ADJUSTMENT METHOD

Service adjustment to this model can be performed with the supplied Remote Control Commander RM-955, 956.

### • HOW TO ENTER INTO SERVICE MODE

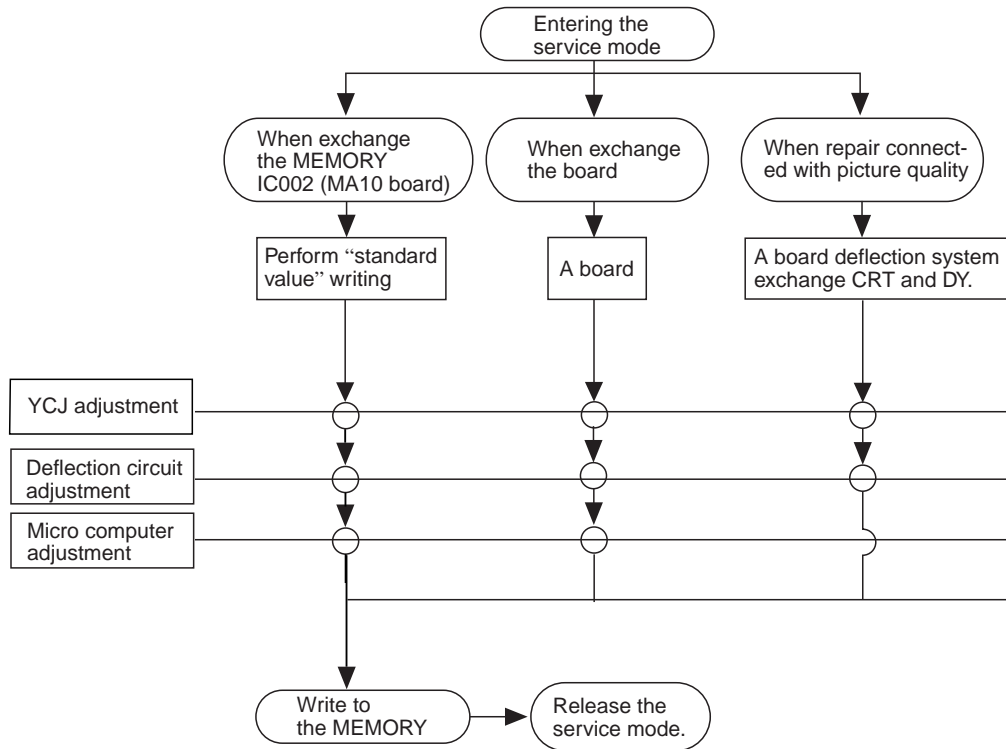

Note : • Write to the MEMORY every performing one item adjustment.  
 • Before writing to the MEMORY adjusted data would not memorize when turn off.

### • REMOTE COMMANDER'S FUNCTION IN SERVICE MODE

### • SERVICE MODE DISPLAY

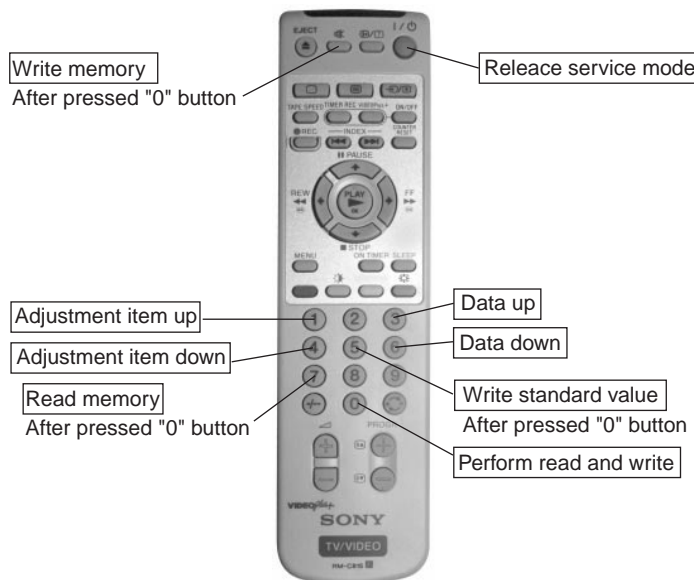

SERVICE			
No.	DATA	ITEM	
VP00	VPOS	000	SERVI
21	D05	VPS	NS



### 4-3. SERVICE DATA

No.	DISP	DATA RANGE	STANDARD DATA	ITEM	DEVICE
VP00	SBRT	00-3F	17	SUB BRIGHT	CXA2139S (Y/C/J)
VP01	HSIZ	00-3F	27	H SIZE	
VP02	HPOS	00-3F	1B	H POSITION	
VP03	VSIZ	00-3F	1D	V SIZE	
VP04	LCPN	00-3F	1E	LOWERSIDE CORNER PIN	
VP05	UCPN	00-3F	17	UPPERSIDE CORNER PIN	
VP06	AFAG	00-0F	07	AFC ANGLE	
VP07	AFBW	00-0F	07	AFC BOW	
VP08	PAMP	00-3F	0C	PIN AMPLITUDE	
VP09	VPOS	00-3F	22	V POSITION	
VP10	VLIN	00-0F	07	V LINEARITY	
VP11	SCOR	00-0F	07	S CORRECTION	
VP12	AFC	00-03	01	AFC LOOP GAIN SWITCHING	
VP13	TRAP	00-0F	06	TRAPEZIUM	
VP14	HBLK	00-01	00	H BLANKING	
VP15	LBLK	00-0F	07	LEFT H BLANKING	
VP16	RBLK	00-0F	07	RIGHT H BLANKING	
VP17	VUND	00-01	00	V UNDER SCAN	
VP18	EHT	00-0F	07	EHT COMP	
VP19	HSS	00-01	00	SLICE LEVEL OF H SYNC SEPARATION	
VP20	VSS	00-01	00	SLICE LEVEL OF V SYNC SEPARATION	
VP21	HMSK	00-01	01	H MASK	
VP22	RAMP	00-3F	21	R DRIVE	
VP23	GAMP	00-3F	14	G DRIVE	
VP24	BAMP	00-3F	0F	B DRIVE	
VP25	RCUT	00-0F	0F	R CUTOFF	
VP26	GCUT	00-0F	06	G CUTOFF	
VP27	BCUT	00-0F	00	B CUTOFF	
VP28	SCOL	00-3F	21	SUB COLOR FOR PAL	
VP29	SHUE	00-1F	1F	SUB HUE	
VP30	SSHHP	00-0F	07	SUB SHARPNESS	
VP31	SHPF	00-01	00	SHARPNESS F0 SWITCHING	
VP32	PREL	00-01	00	PRE/OVER-SHOOT RATIO SWITCHING	
VP33	GAMM	00-01	02	GAMMA CORRECTION	
VP34	ABLM	00-01	01	ABL MODE	
VP35	VTH	00-01	01	ABL VTH	
VP36	DYCL	00-01	01	DYNAMIC COLOR	
VP37	YDC	00-01	01	DC TRAN	
VP38	RON	00-01	01	R ON	
VP39	GON	00-01	01	G ON	
VP40	BON	00-01	01	B ON	
VP41	CDMD	00-03	00	COUNT DOWN MODE	
VP42	HOSC	00-0F	07	H VCO'S OSCILLATION	
VP43	VMSW	00-01	00	VM SW	
VP44	YDE	00-0F	00	Y DELAY	
VP45	PAF	00-03	00	PB AFC	
VP46	IDS	00-03	02	ID START	
VP47	IDP	00-03	02	ID STOP	
VP48	IDL	00-03	02	ID LEVEL	
VP49	BELL	00-3F	25	BELL F0	
VP50	SCSE	00-3F	1F	SUB COLOR FOR SECAM	
VP51	GDSE	00-0F	07	G DRIVE (SECAM) *DISPLAY -7 to +8*	
VP52	BDSE	00-0F	07	B DRIVE (SECAM) *DISPLAY -7 to +8*	
VP53	RCSE	00-1F	10	R CUTOFF (SECAM) *DISPLAY -15 to +16*	
VP54	GCSE	00-1F	10	G CUTOFF (SECAM) *DISPLAY -15 to +16*	
VP55	BCSE	00-1F	10	B CUTOFF (SECAM) *DISPLAY -15 to +16*	
VP56	GDLI	00-0F	07	G DRIVE (LIVE) *DISPLAY -7 to +8*	
VP57	BDLI	00-0F	07	B DRIVE (LIVE) *DISPLAY -7 to +8*	
VP58	RCLI	00-0F	07	R CUTOFF (LIVE) *DISPLAY -7 to +8*	
VP59	GCLI	00-0F	07	G CUTOFF (LIVE) *DISPLAY -7 to +8*	
VP60	BCLI	00-0F	07	B CUTOFF (LIVE) *DISPLAY -7 to +8*	

No.	DISP	DATA RANGE	STANDARD DATA	ITEM	DEVICE
IF00	AMFM	00-01	00	AUTO MUTE FM	
IF01	GAIN	00-01	00	AUDIO GAIN	
IF02	GATE	00-01	00	GATING (POSITIVE MODULATION)	
IF03	TOP	00-1F	10	TAKE OVER POINT *DISPLAY -16 to +15*	CXP85452 ( $\mu$ -COM)
IF04	TAGC	00-1F	10	AGC FOR TV TUNER *DISPLAY -16 to +15*	
IF05	VAGC	00-1F	10	AGC FOR VCR TUNER *DISPLAY -16 to +15*	

No.	DISP	DATA RANGE	STANDARD DATA	ITEM	DEVICE
OP00	OSDH	00-3F	06	OSD HORIZONTAL POSITION	CXP85452 ( $\mu$ -COM)
OP01	NS	00-01	01	NS COIL	
OP02	LWAI	00-1F	13	L SYSTEM TUNING WAIT TIMER	
OP03	HDCG	00-03	00	HEADCLOG DETECT	
OP04	MUT	00-01	01	FTZ MUTE (0:OFF 1:ON)	
OP05	VPS	00-01	01	VPS (0:NO EXIST 1:EXIST)	
OP06	BDES	00-01	00	B DESTINATION (0:OTHERS 1:B)	
OP07	UDES	00-01	00	U DESTINATION (0:OTHERS 1:U)	
OP08	ID0	00-01	00	PAINTER M3A/M3C SELECT (0:M3A 1:M3C)	
OP09	ID1	00-01	00	NVM-ID1 (RESERVE)	

#### 4-4. A BOARD ADJUSTMENT

##### 1. SUB COLOUR ADJUSTMENT

- 1) Recieve the PAL colour bar signal.
- 2) Check the pin④ of CN305 by oscilloscope.
- 3) Adjust the part of the right waveform to become the same level by service mode (VP28:Sub colour).

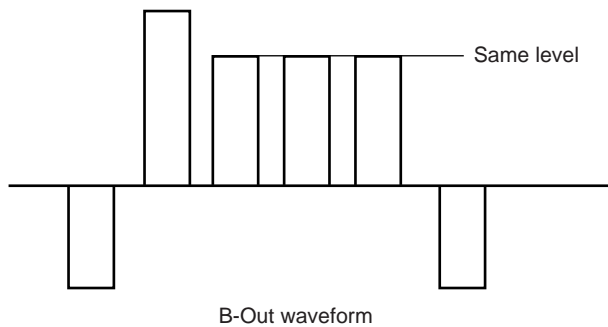
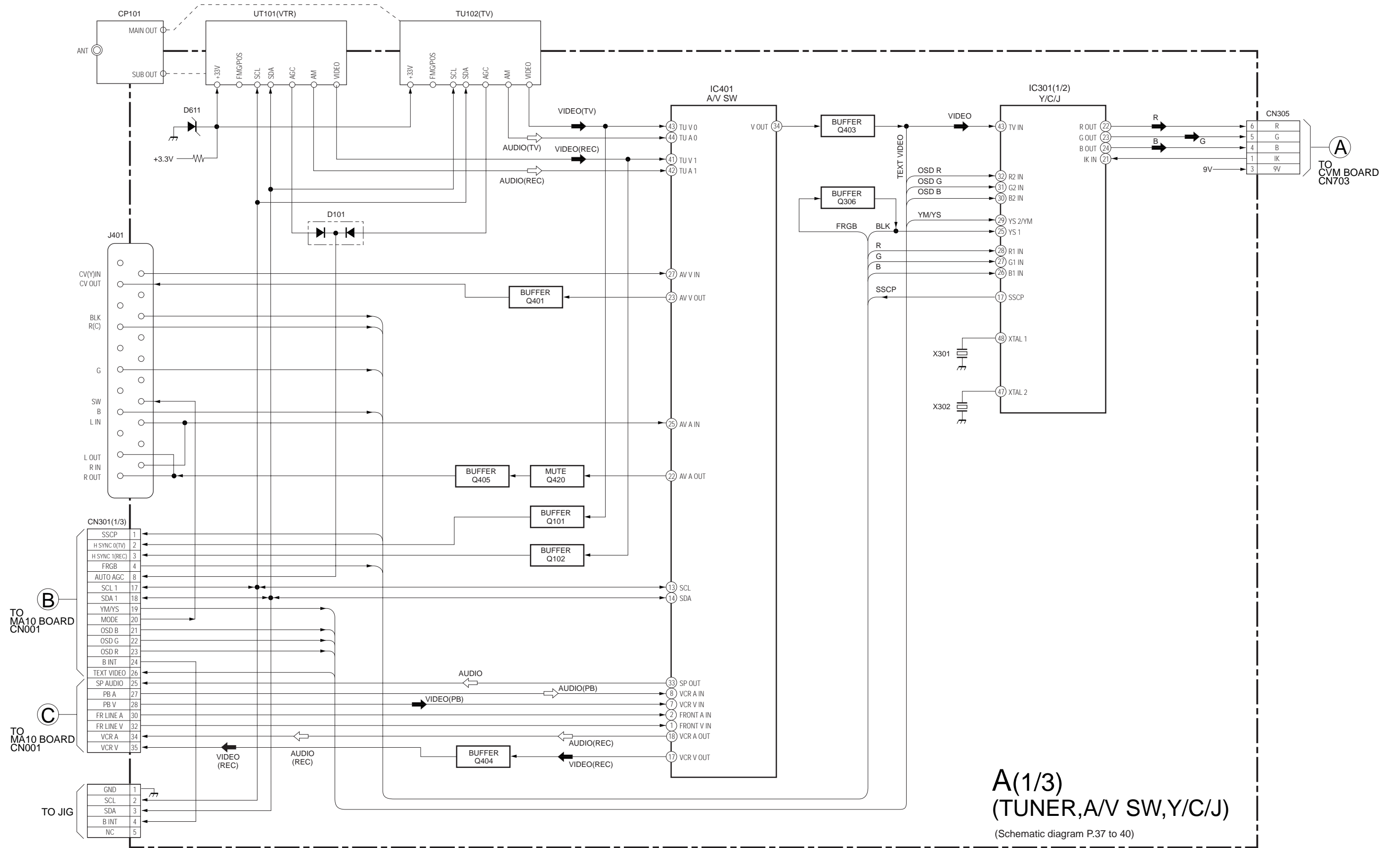

**Fig.4-1**

**TV BLOCK**

**SECTION 5  
DIAGRAMS**

**5-1. BLOCK DIAGRAMS**



(15)



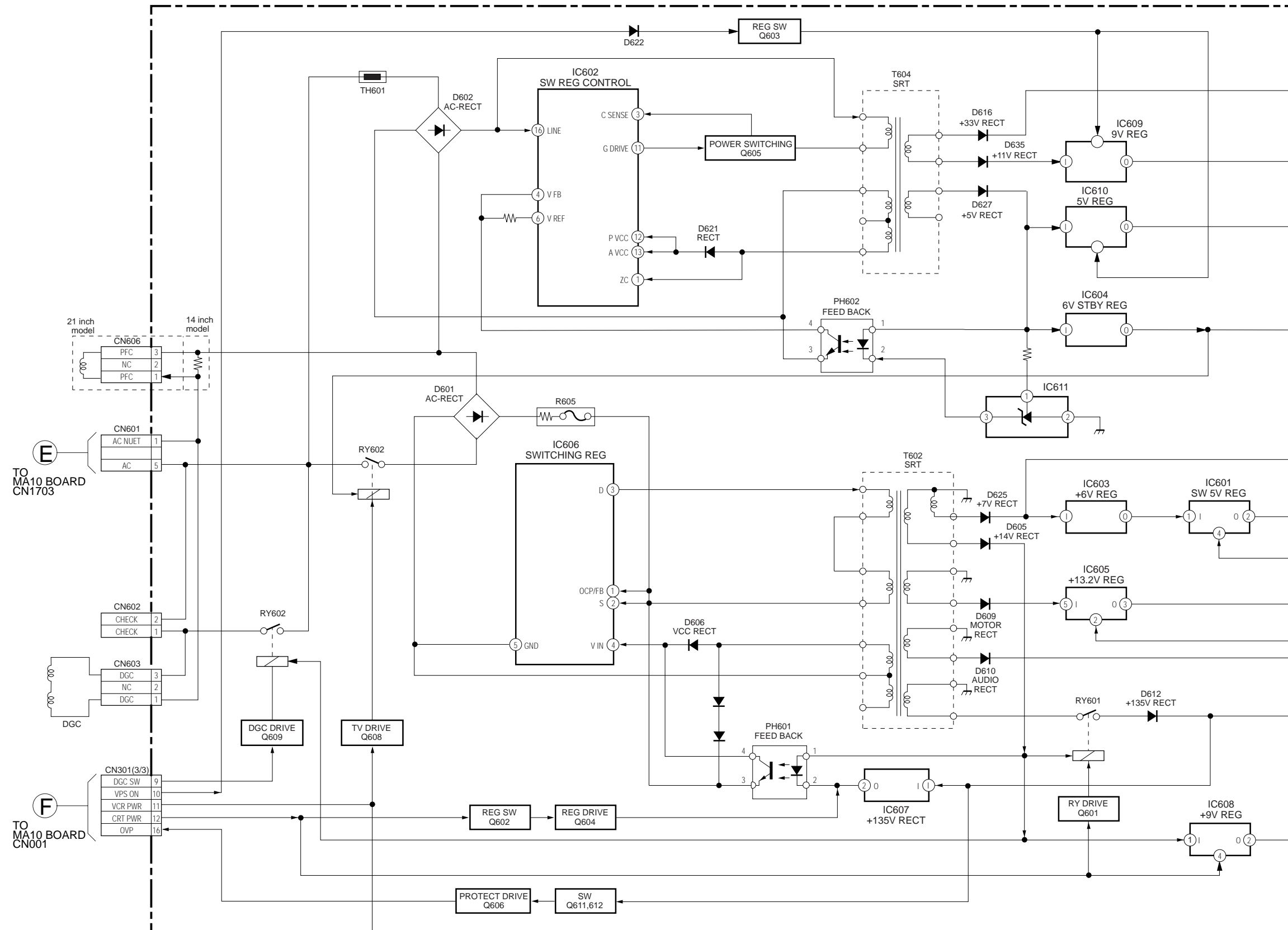

**A(3/3)**  
**(POWER SUPPLY)** (Schematic diagram P.37 to 40)

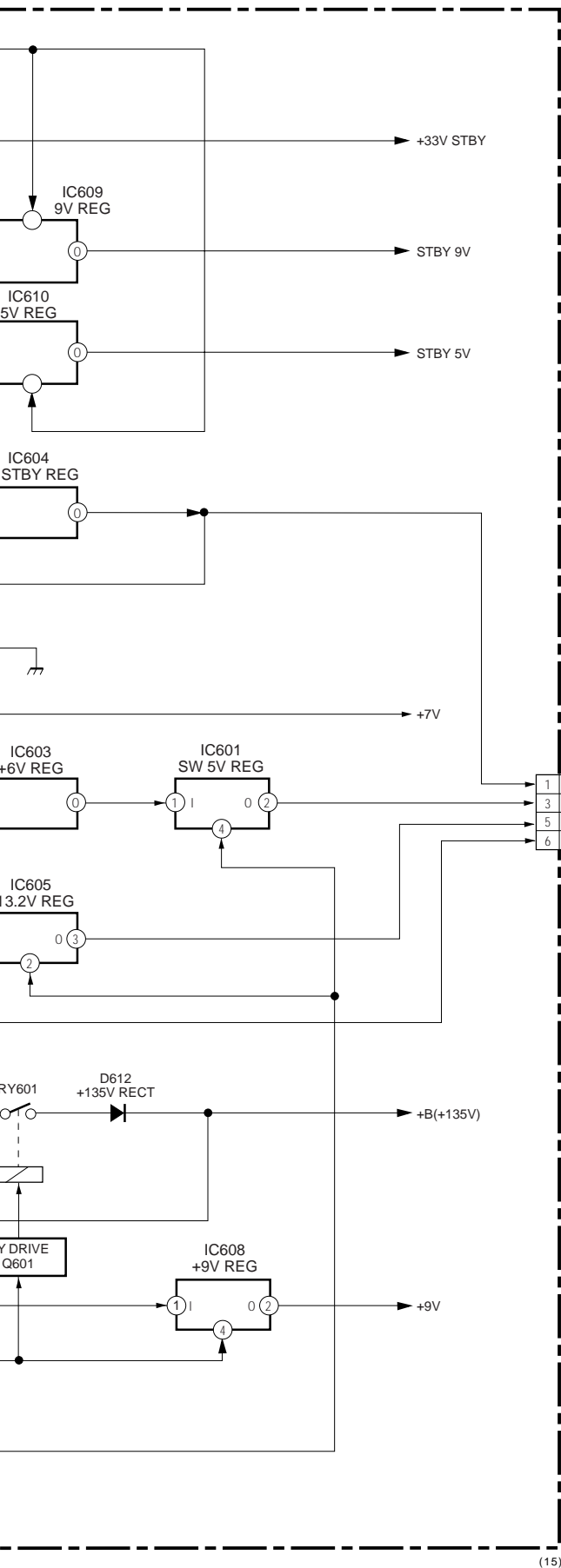

### 5-2. CIRCUIT BOARDS LOCATION

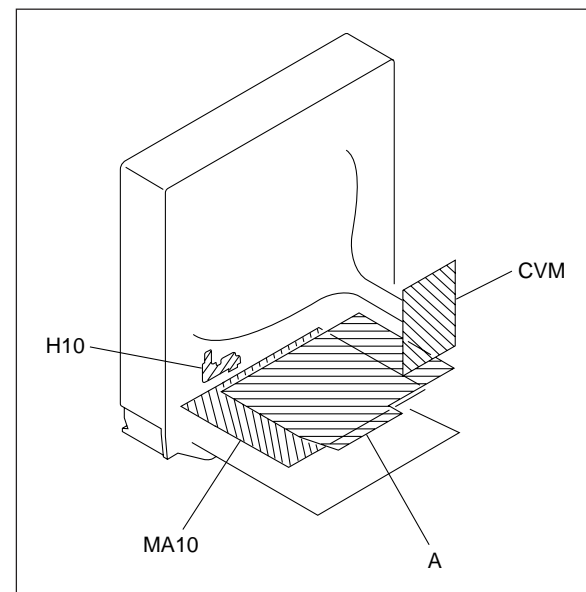

### 5-3. PRINTED WIRING BOARDS AND SCHEMATIC DIAGRAMS

Note:

- All capacitors are in  $\mu\text{F}$  unless otherwise noted.  $\text{pF}$ :  $\mu\text{pF}$   
Capacitors without voltage indication are all 50V.
- All resistors are in ohms.  
 $k = 1000$ ,  $M = 1000k$
- Indication of resistance, which does not have one for rating electrical power, is as follows.  
Pitch: 5 mm  
Rating electrical power: 1/4W(CHIP:1/10W)
- : nonflammable resistor.
- : fusible resistor.
- $\Delta$  : internal component.
- : panel designation and adjustment for repair.
- All variable and adjustable resistors have characteristic curve B, unless otherwise noted.
- $\oplus$  : earth-chassis.

- Readings are taken with a color-bar signal input.
- Readings are taken with a 10M digital multimeter.
- Voltage variations may be noted due to normal production tolerances.
- All voltages are in V.
- Circled numbers are waveform reference.
- : B + line.
- : B - line.
- : signal path.

**Note:** The components identified by shading and mark  $\Delta$  are critical for safety. Replace only with part number specified.

Reference information

- RESISTOR : RN METAL FILM
- : RC SOLID
- : FPRD NONFRAMMABLE CARBON
- : FUSE NONFRAMMABLE FUSIBLE
- : RW NONFRAMMABLE WIREWOUND
- : RS NONFRAMMABLE METAL OXIDE
- : RB NONFRAMMABLE CEMENT
- : \* ADJUSTMENT RESISTOR
- COIL : LF-8L MICRO INDUCTOR
- CAPACITOR : TA TANTALUM
- : PS STYROL
- : PP POLYPROPYLENE
- : PT MYLAR
- : MPS METALIZED POLYESTER
- : MPP METALIZED POLYPROPYLENE
- : ALB BIPOLAR
- : ALT HIGH TEMPERATURE
- : ALR HIGH RIPPLE

### Terminal name of semiconductors in silk screen printed circuit (\* )

Device	Printed symbol	Terminal name	Circuit
① Transistor		Collector Base Emitter	
② Transistor		Collector Base Emitter	
③ Diode		Cathode Anode	
④ Diode		Cathode Anode (NC)	
⑤ Diode		Cathode Anode (NC)	
⑥ Diode		Common Anode Cathode	
⑦ Diode		Common Anode Cathode	
⑧ Diode		Common Anode Anode	
⑨ Diode		Common Anode Anode	
⑩ Diode		Common Cathode Cathode	
⑪ Diode		Common Cathode Cathode	
⑫ Diode		Anode Cathode Anode Cathode	

(Chip semiconductors that are not actually used are included.)

Ver.1.6

**Note:** Les composants identifiés par la marque  $\Delta$  sont critiques pour la sécurité. Ne les remplacer que par une pièce portant le numéro spécifié.

# A

[TUNER, A/V SW, Y/C/J, HV DEFLECTION, POWER SUPPLY]

## A BOARD

IC			
IC301	K-2	D314	J-3
IC401	F-6	D401	D-8
IC501	L-4	D402	G-5
IC601	A-2	D404	E-8
IC602	D-6	D405	D-8
IC603	A-3	D406	D-8
IC604	F-2	D407	E-8
IC605	B-3	D408	E-7
IC606	A-4	D410	C-8
IC607	F-2	D411	C-8
IC608	K-3	D412	E-8
IC609	F-3	D413	E-8
IC610	G-3	D414	E-8
IC611	F-3	D501	L-5
IC801	L-2	D502	L-3
		D503	L-4
		D506	J-5
		D507	L-5
		D601	B-7
		D602	C-7
		D604	F-3
		D605	B-2
		D606	A-4
		D607	D-7
		D608	I-2
		D609	C-3
		D610	C-3
		D611	E-7
		D612	D-2
		D613	D-5
		D614	D-2
		D615	C-8
		D616	C-3
		D617	B-4
		D618	A-4
		D619	A-4
		D620	A-4
		D621	D-4
		D622	F-3
		D623	—
		D624	E-1
		D625	A-2
		D626	C-4
		D627	D-3
		D628	E-1
		D629	E-2
		D631	D-5
		D632	C-8
		D633	K-3
		D634	E-2
		D635	D-3
		D636	I-3
		D637	F-2
		D638	G-3
		D639	F-2
		D801	K-6
		D803	I-4
		D804	H-5
		D805	L-3
		D807	H-6
		D810	J-9
		D811	H-9
		D812	G-7

  

TRANSISTOR			
Q101	F-4	*	①
Q102	F-3	①	①
Q301	K-3	①	①
Q302	J-3	①	①
Q303	K-3	①	①
Q304	I-3	①	①
Q305	J-3	①	①
Q306	I-2	①	①
Q401	F-7	①	①
Q402	F-7	①	①
Q403	G-6	①	①
Q404	E-5	①	①
Q405	F-7	①	①
Q501	K-3	①	①
Q502	K-3	①	①
Q601	E-2	①	①
Q602	E-2	①	①
Q603	F-3	①	①
Q604	E-1	①	①
Q605	D-4	①	①
Q606	H-2	①	①
Q608	B-8	①	①
Q609	F-3	①	①
Q611	I-3	①	①
Q612	I-3	①	①
Q801	J-4	①	①
Q802	I-8	①	①
Q803	H-7	①	①

DIODE			
D101	E-7	*	①
D102	—	①	①
D103	—	①	①
D301	J-1	①	①
D302	J-1	①	①
D304	K-2	①	①
D305	L-3	①	①
D307	K-2	①	①
D308	I-2	①	①
D313	I-1	①	①

\*: Refer to Terminal name of semiconductors in silk screen printed circuit (see page 33).

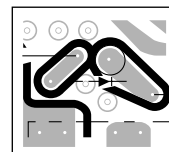

**NOTE:**  
The circuit indicated as left contains high voltage of over 600 Vp-p. Care must be paid to prevent an electric shock in inspection or repairing.

## - A BOARD -

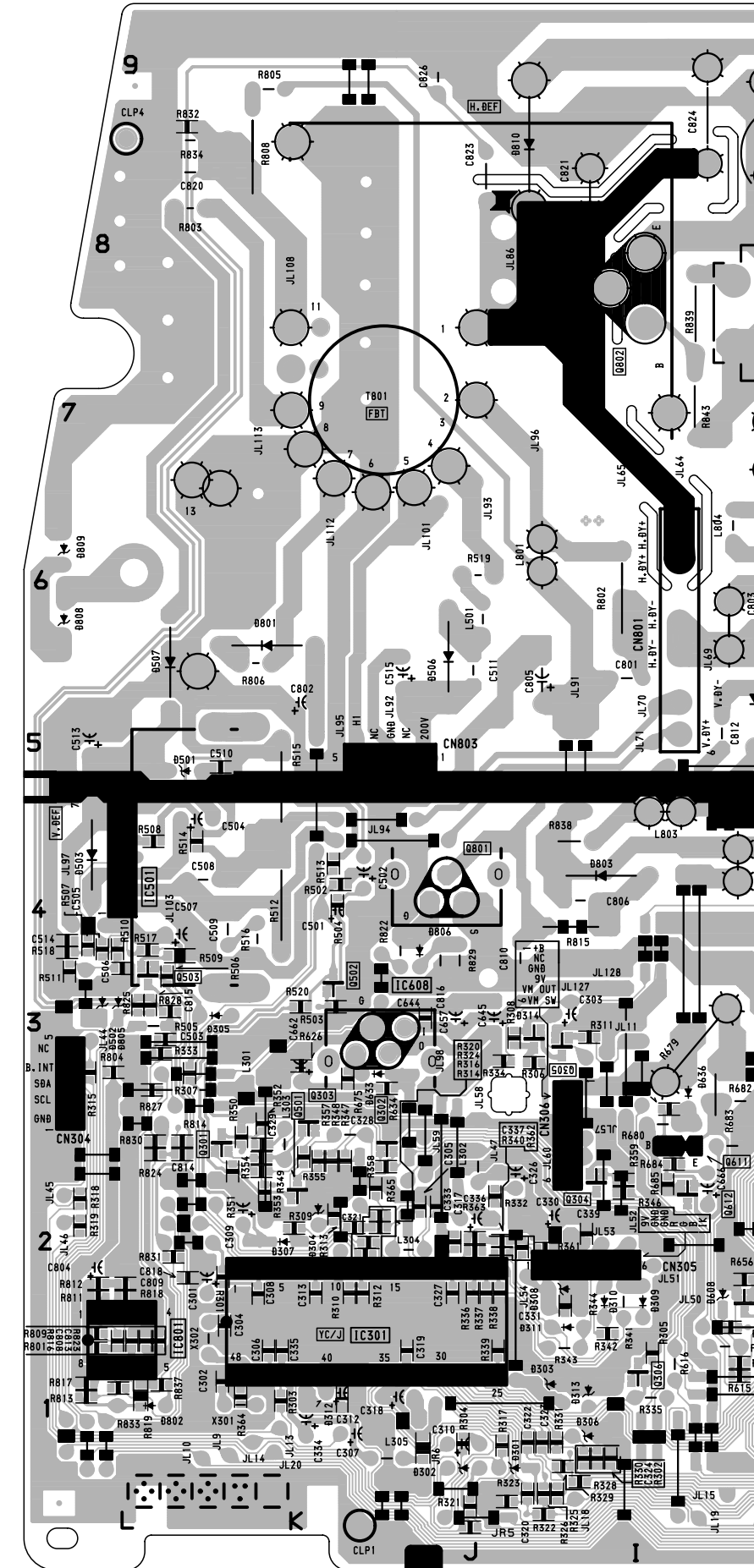

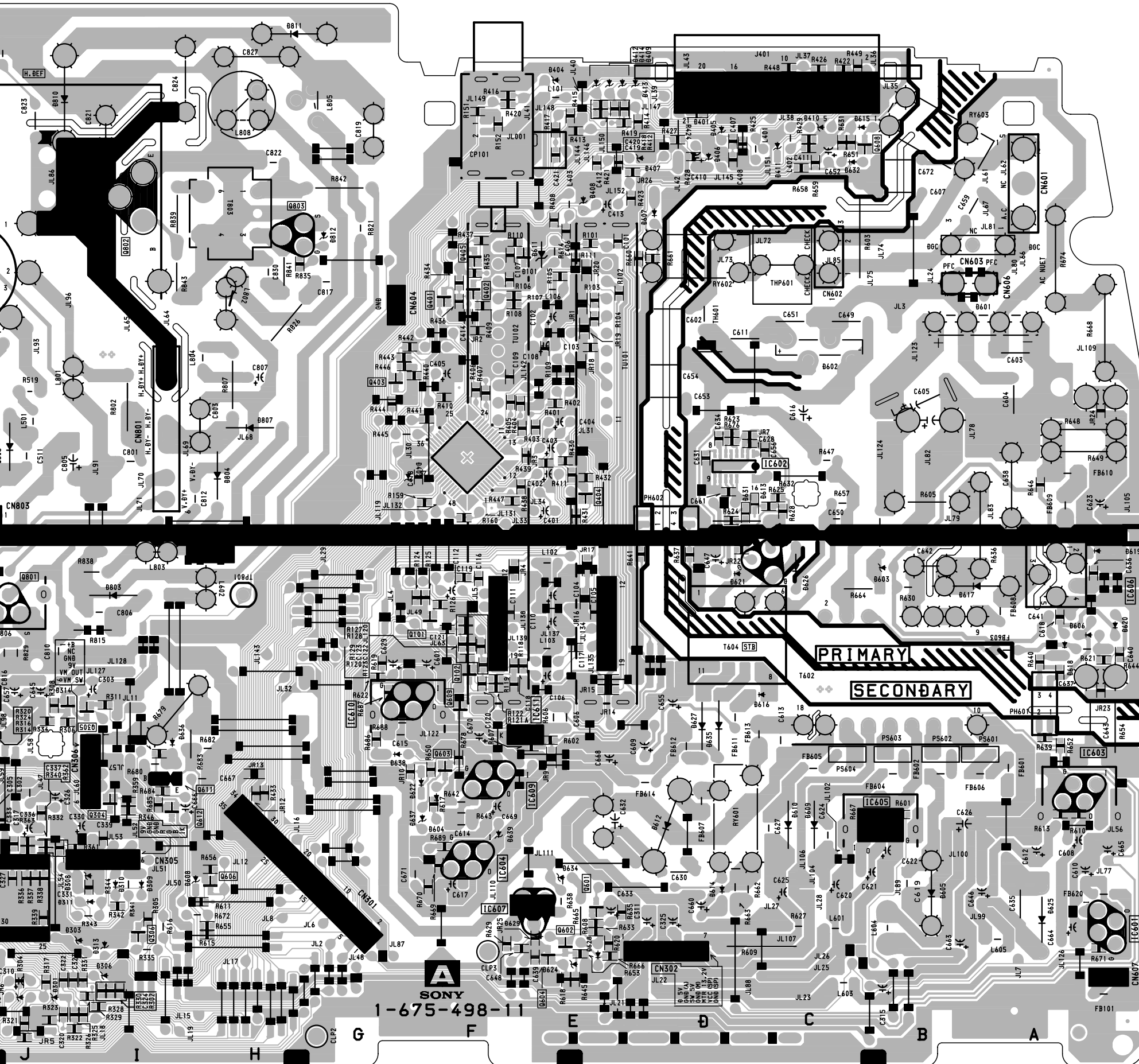



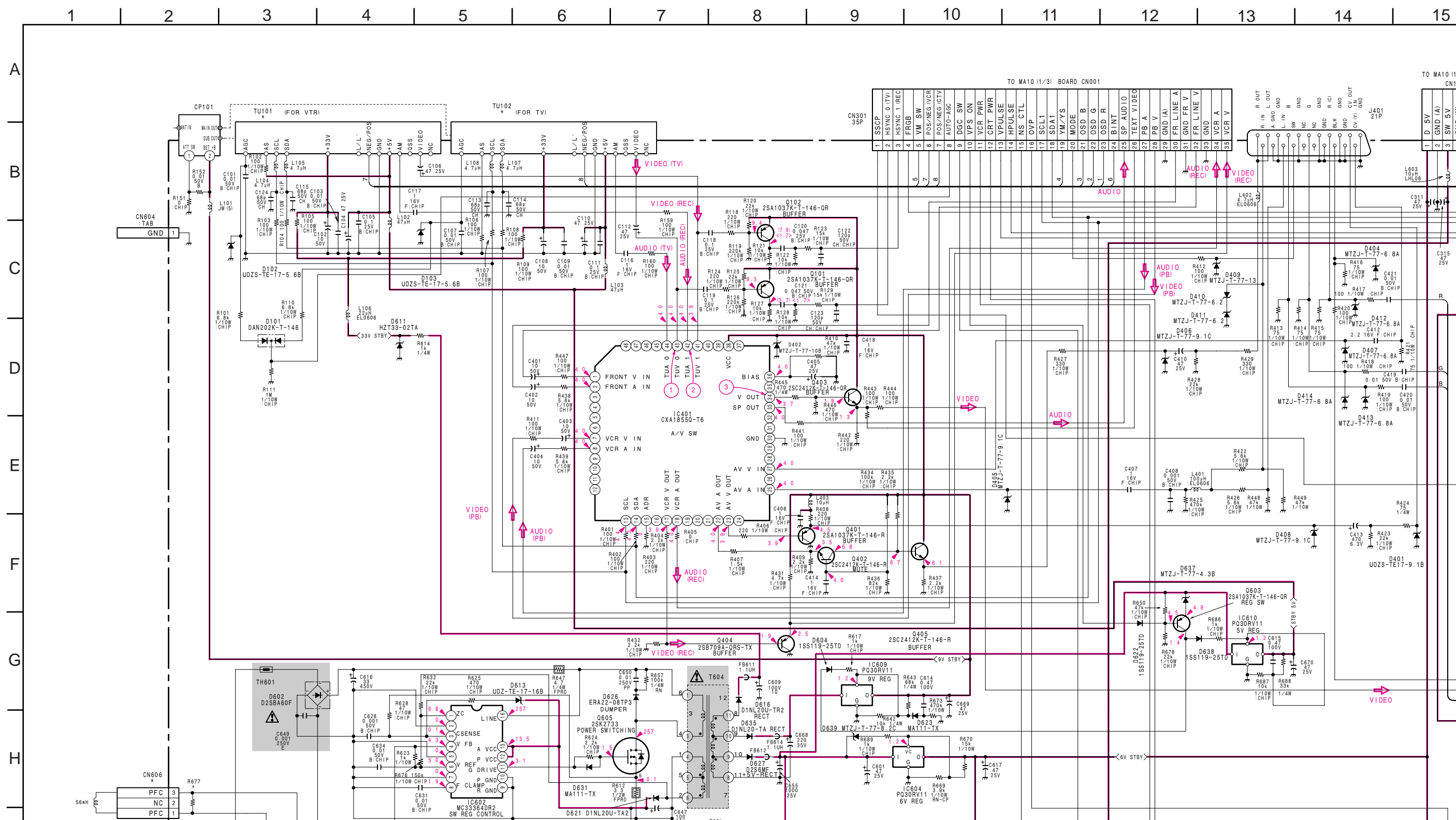

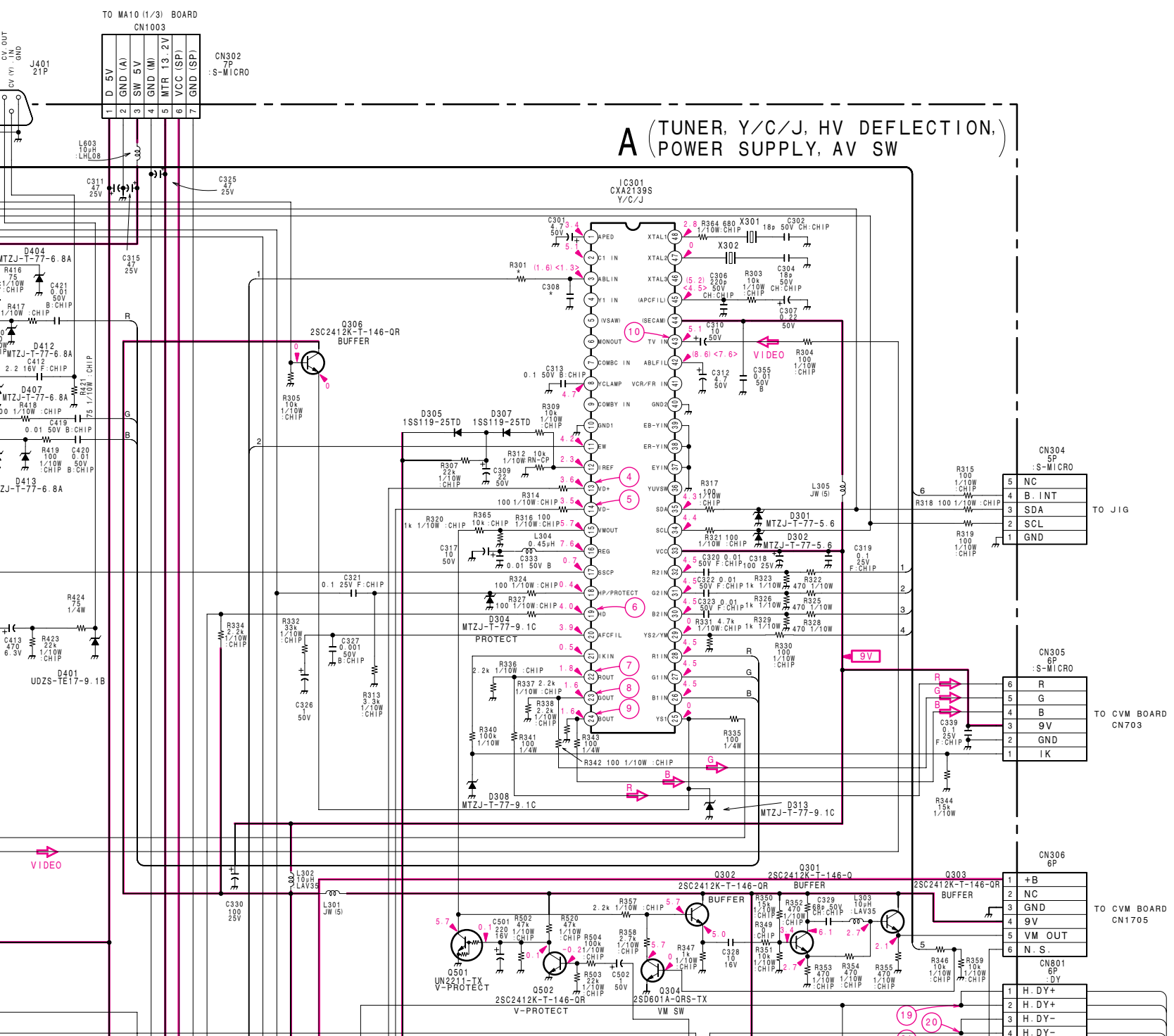

**A (TUNER, Y/C/J, HV DEFLECTION, POWER SUPPLY, AV SW)**

ABOARD : IC501 LA7840L

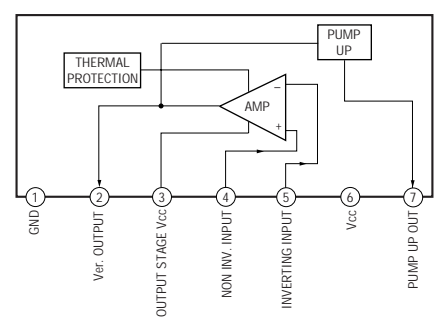

ABOARD : IC606 STR-F6654

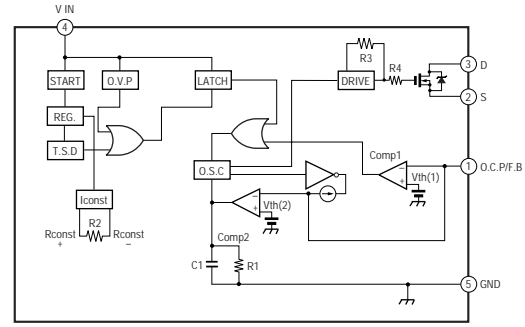

**A BOARD \* MARK LIST**

Ref No.	14inch model	21inch model
C303	—	10
C308	0.033 50V B:CHIP	0.47 16V B:CHIP
C801	0.015 200V :PT	0.01 400V :PT
C803	0.36 250V	0.47 250V
C806	100p 500V	100p 500V
C812	0.022 200V	0.033 250V
C813	4700p 25V SL:CHIP	0.0022 50V SL:CHIP
C817	470p 50V	JW(5)
C818	330p CH:CHIP	0.01 CH:CHIP
C820	0.022 200V :PT	0.047 200V :PT
C821	680p 2kV B	470p 2kV B
C824	5600p 1.2kV	9100p 1.2kV
C827	0.015 630V :PP	0.36 400V :PP
CN606	—	3P(3.3 10W)
D314	—	DAP202K-T-146
L802	1-419-551-11	1-419-552-11
L805	COIL,CHOKE(10MMH)	COIL,DRAM CORE
L808	COIL,CHOKE(1.5MMH)	COIL,WITH CORE
Q305	—	2SC2412K-T-146-R
R301	33k :CHIP	2.2k :CHIP
R306	—	10k :CHIP
R308	—	10k :CHIP
R311	—	10k :CHIP
R677	3.3 10W	—
R801	470k :RN-CP	330k :RN-CP
R802	27 2W :RS	47 2W :RS
R805	82k :RN	33k :RN
R808	82k 1/4W :RN	56k 1/2W :RN
R810	—	22k :RN-CP
R824	110k :RN-CP	100k :RN-CP
R830	39k :RN-CP	47k :RN-CP
R831	75k :RN-CP	510k :RN-CP
R832	10k :RN-CP	2.7k :RN-CP
R838	JW(15)	100 2W :RS
T801	NX-1912-M	1-453-314-11

—: Not used

**A BOARD \* MARK LIST**

Ref No.	AEP/ESP model	FR model	UK model
TU101	BTF-EC402	BTF-EF412	BTF-EU602
TU102	BTF-EC402	BTF-EF412	BTF-EU602

—: Not used

**A BOARD WAVEFORMS**

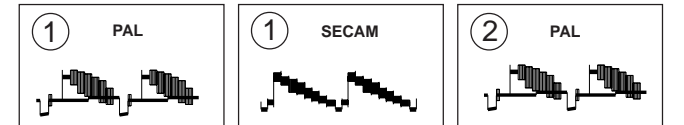

H  
I  
J  
K  
L  
M  
N  
O  
P

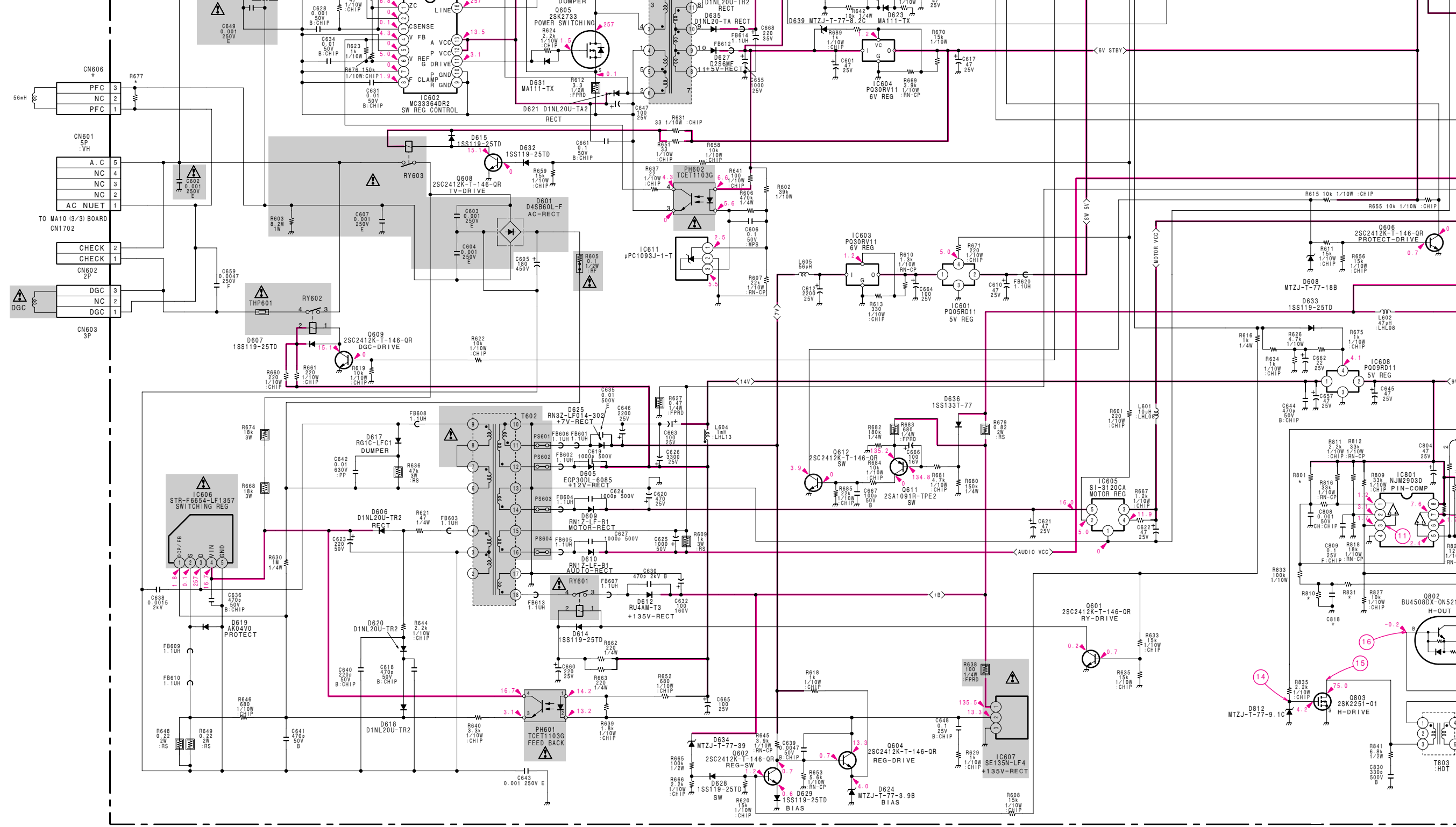

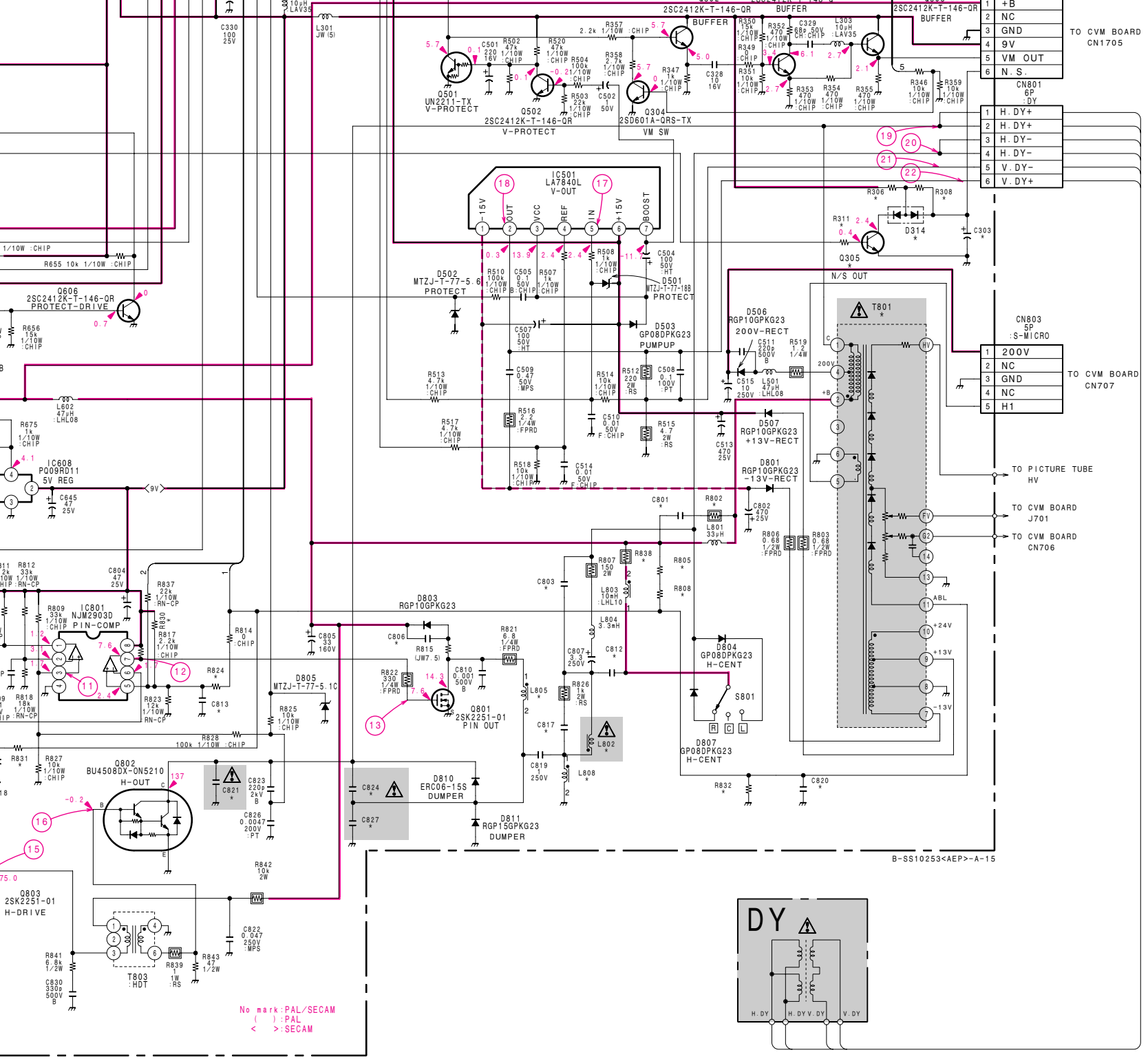

### A BOARD WAVEFORMS

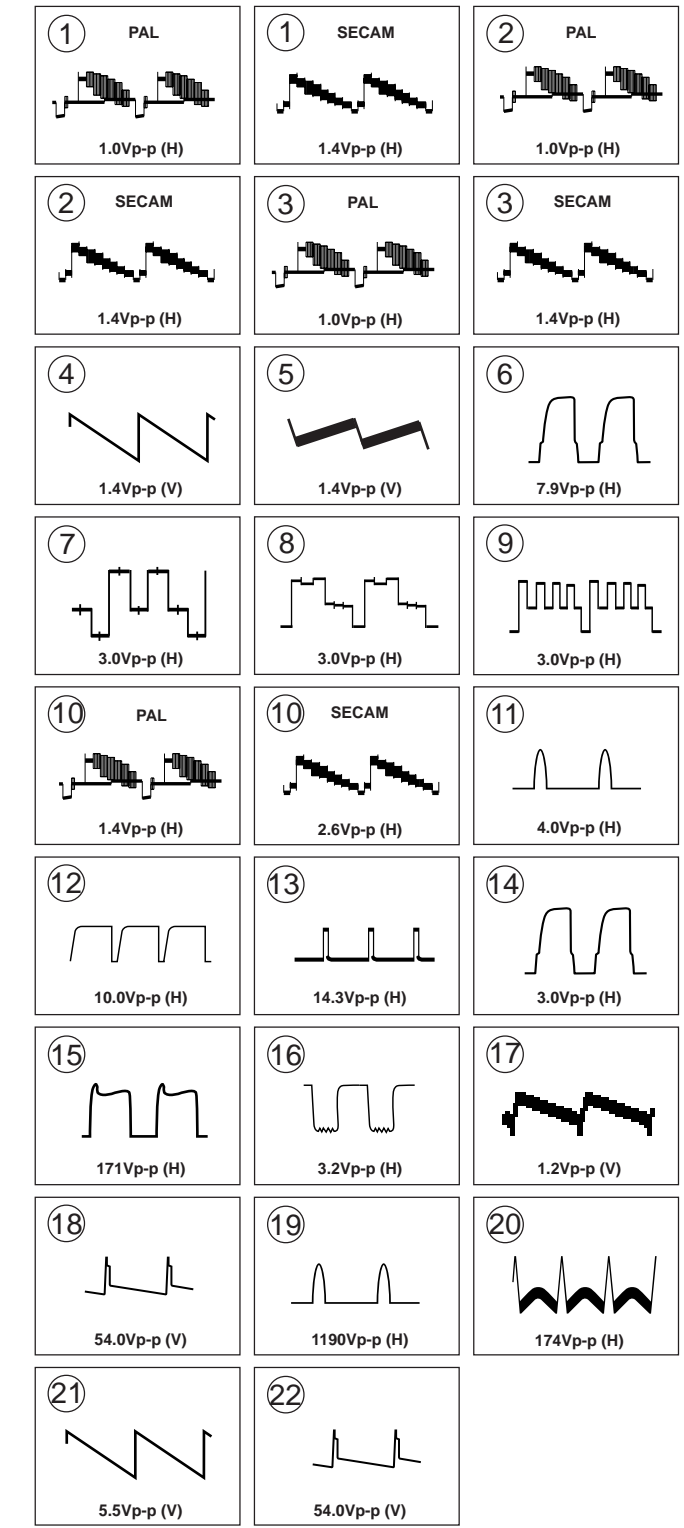

—: Not used

**CVM BOARD WAVEFORMS**

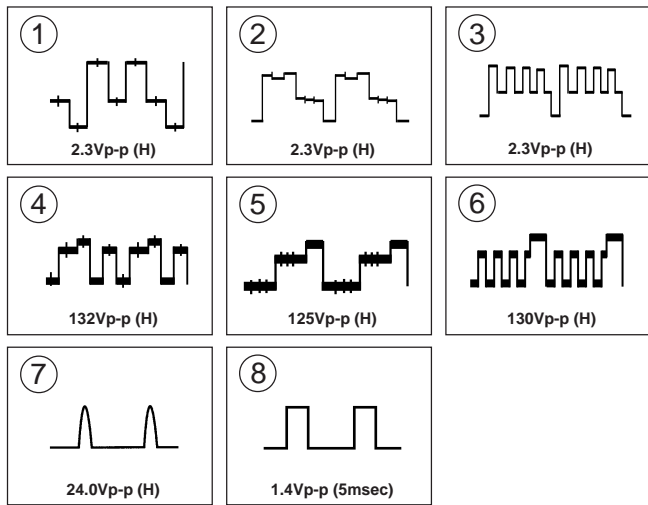

**CVM BOARD : IC1801 M5216P**

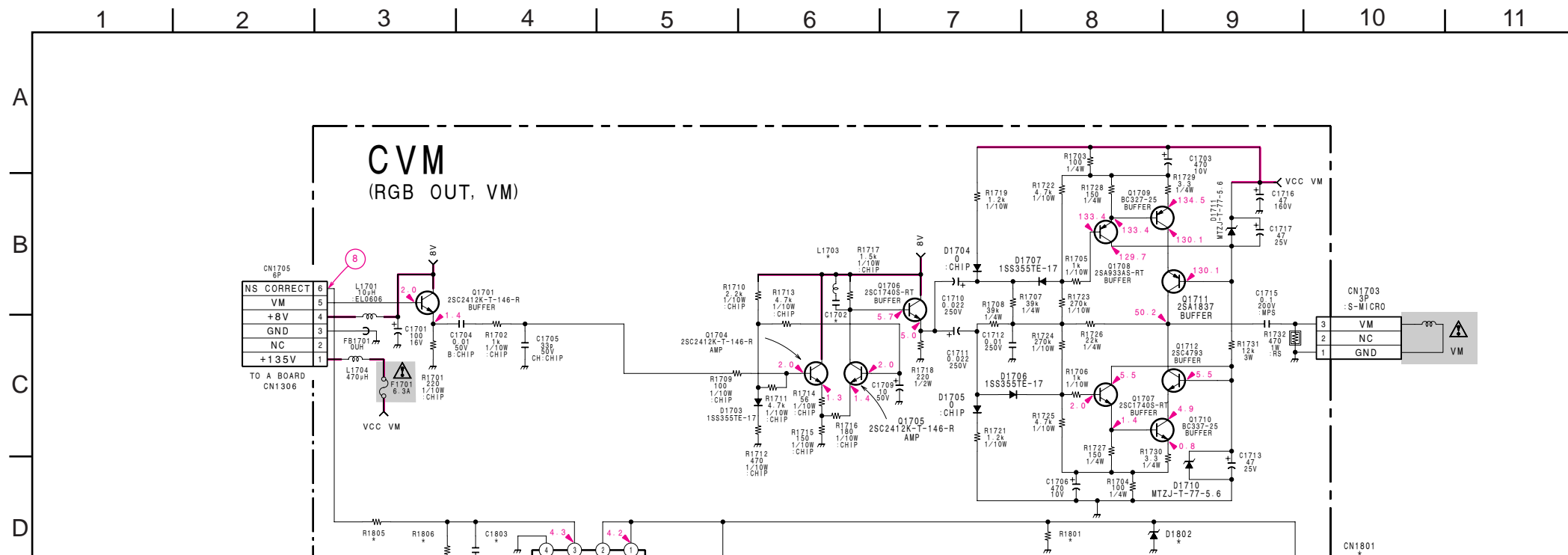
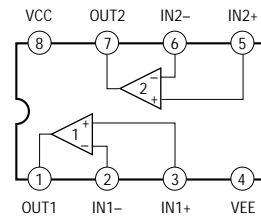

**CVM** [RGB OUT,VM]

– CVM BOARD –

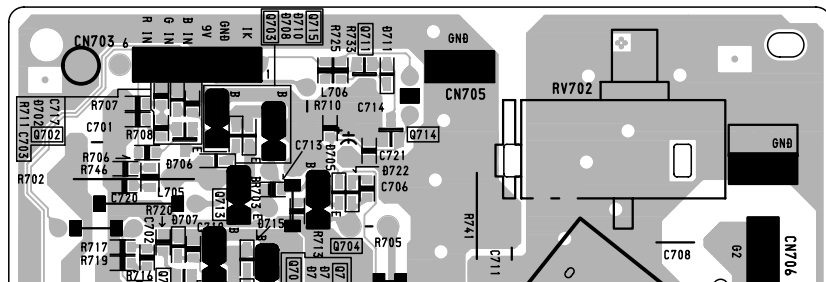

## VIDEO section

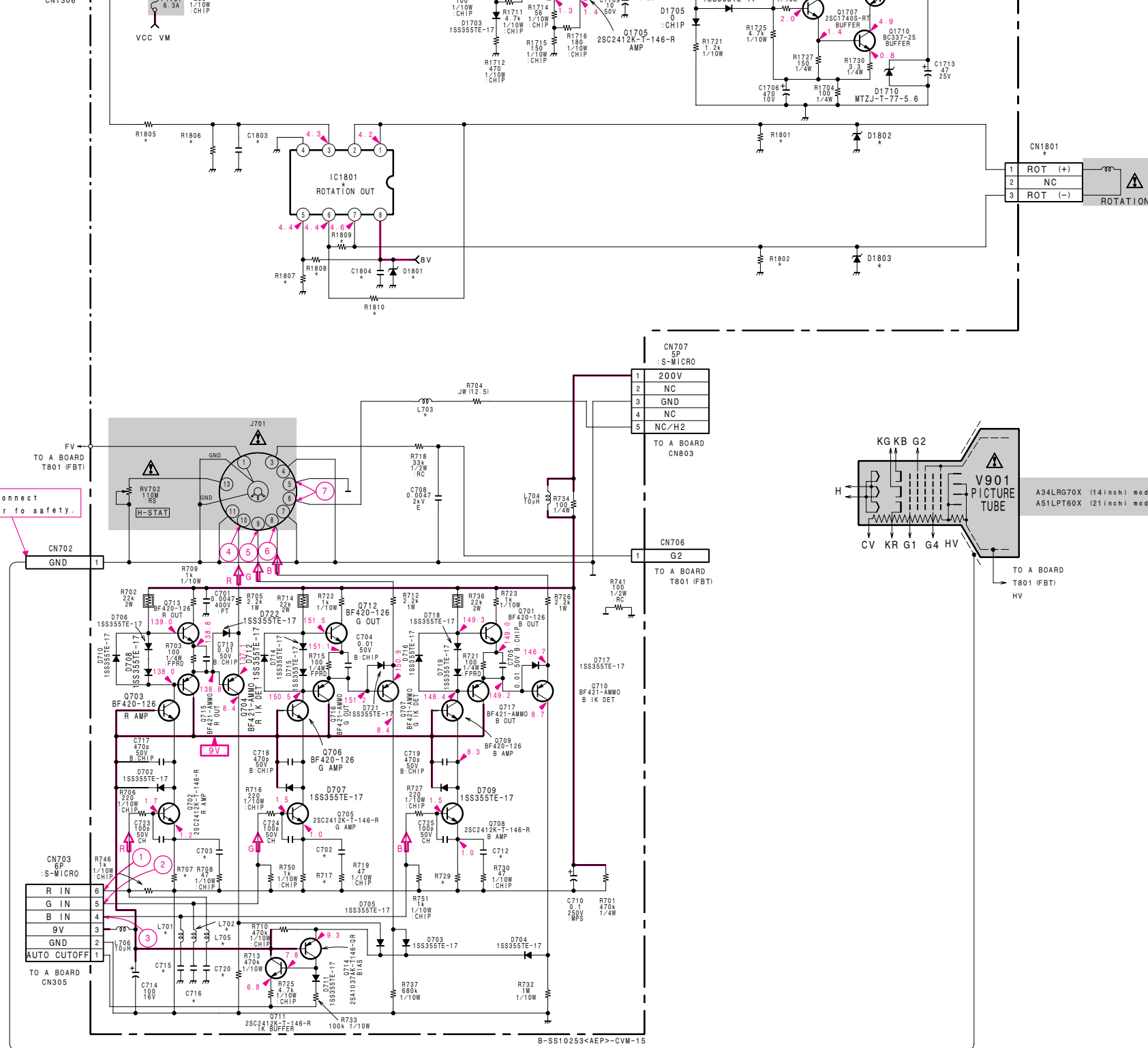

**CVM BOARD \* MARK LIST**

Ref No.	14inch model	21inch model
C702	100p CH:CHIP	150p CH:CHIP
C703	100p CH:CHIP	150p CH:CHIP
C712	100p CH:CHIP	150p CH:CHIP
C715	—	68p CH:CHIP
C716	—	68p CH:CHIP
C720	—	68p CH:CHIP
C1702	—	22p CH:CHIP
C1803	—	0.022 B:CHIP
C1804	—	1 16V B:CHIP
CN1801	—	3P
D1801	—	UDZ-TE-1-10B
D1802	—	UDZ-TE-1-10B
D1803	—	UDZ-TE-1-10B
IC1801	—	M5216P
L701	—	4.7UH
L702	—	4.7UH
L703	27UH	47UH
L705	—	4.7UH
L1703	—	15UH
R707	560 :CHIP	390 :CHIP
R717	560 :CHIP	390 :CHIP
R729	560 :CHIP	390 :CHIP
R1801	—	1K :CHIP
R1802	—	1K :CHIP
R1805	—	10K :CHIP
R1806	—	680K :CHIP
R1807	—	10K :CHIP
R1808	—	10K :CHIP
R1809	—	10K :CHIP
R1810	—	10K :CHIP

—: Not used

Schematic diagram



Schematic diagram



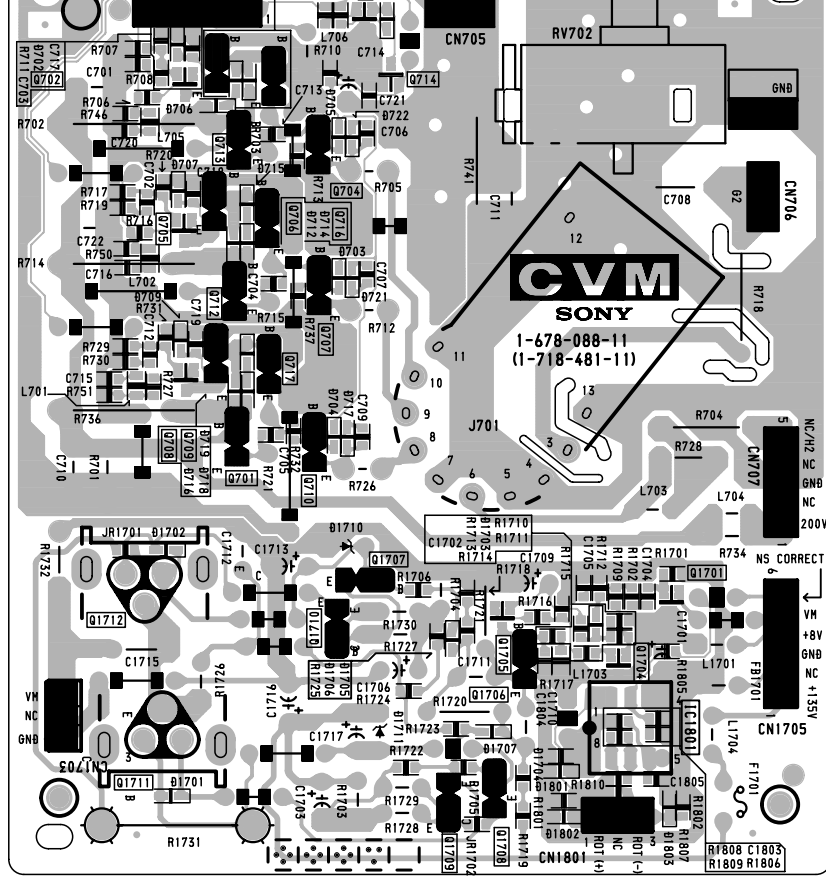

**NOTE:**  
 The circuit indicated as left contains high voltage of over 600 Vp-p. Care must be paid to prevent an electric shock in inspection or repairing.



## TABLE OF CONTENTS

<u>Section</u>	<u>Title</u>	<u>Page</u>	<u>Section</u>	<u>Title</u>	<u>Page</u>
<b>[ VIDEO SECTION]</b>			<b>5. DIAGRAMS</b>		
<b>1. GENERAL</b>			5-1.	Block Diagrams .....	55
1-1.	INTERNAL VIEWS .....	46	5-2.	Circuit Boards Location .....	59
<b>2. DISASSEMBLY</b>			5-3.	Printed Wiring Boards and Schematic Diagrams ....	59
2-1.	Top Cover Removal .....	47	•	H10 Board .....	60
2-2.	VCR Block Assy Removal .....	47	•	MA10 (1/3) Board .....	65
2-3.	H10 Board Removal .....	47	•	MA10 (2/3) Board .....	69
2-4.	MA10 Board Removal .....	47	•	MA10 (3/3) Board .....	73
2-5.	Service Position (MA10 Board) .....	47	5-4.	Semiconductors .....	75
<b>3. CIRCUIT ADJUSTMENTS</b> .....			<b>6. EXPLODED VIEWS</b>		
48			6-3.	Mechanism Deck Assembly (1) .....	79
<b>4. INTERFACE, IC PIN FUNCTION DESCRIPTION</b>			6-4.	Mechanism Deck Assembly (2) .....	80
4-1.	$\mu$ -COM Poart Function Description (MA10 Board IC001) .....	51	6-5.	Mechanism Deck Assembly (3) .....	81
4-2.	System Control-Video Block Interface (MA10 Board IC402) .....	52	<b>7. ELECTRICAL PARTS LIST</b> .....		
4-3.	System Control-Servo Peripheral Circuit Interface (MA10 Board IC402) .....	52	90		
4-4.	System Control-Mechanism Block Interface (MA10 Board IC402) .....	53			
4-5.	System Control-System Control Peripheral Circuit Interface (MA10 Board IC402) .....	53			
4-6.	System Control-Audio Block Interface (MA10 Board IC402) .....	53			
4-7.	Servo/System Control Port Function Description (MA10 Board IC402) .....	54			

# SECTION 1 GENERAL

## 1-1. INTERNAL VIEWS

- Top Side -

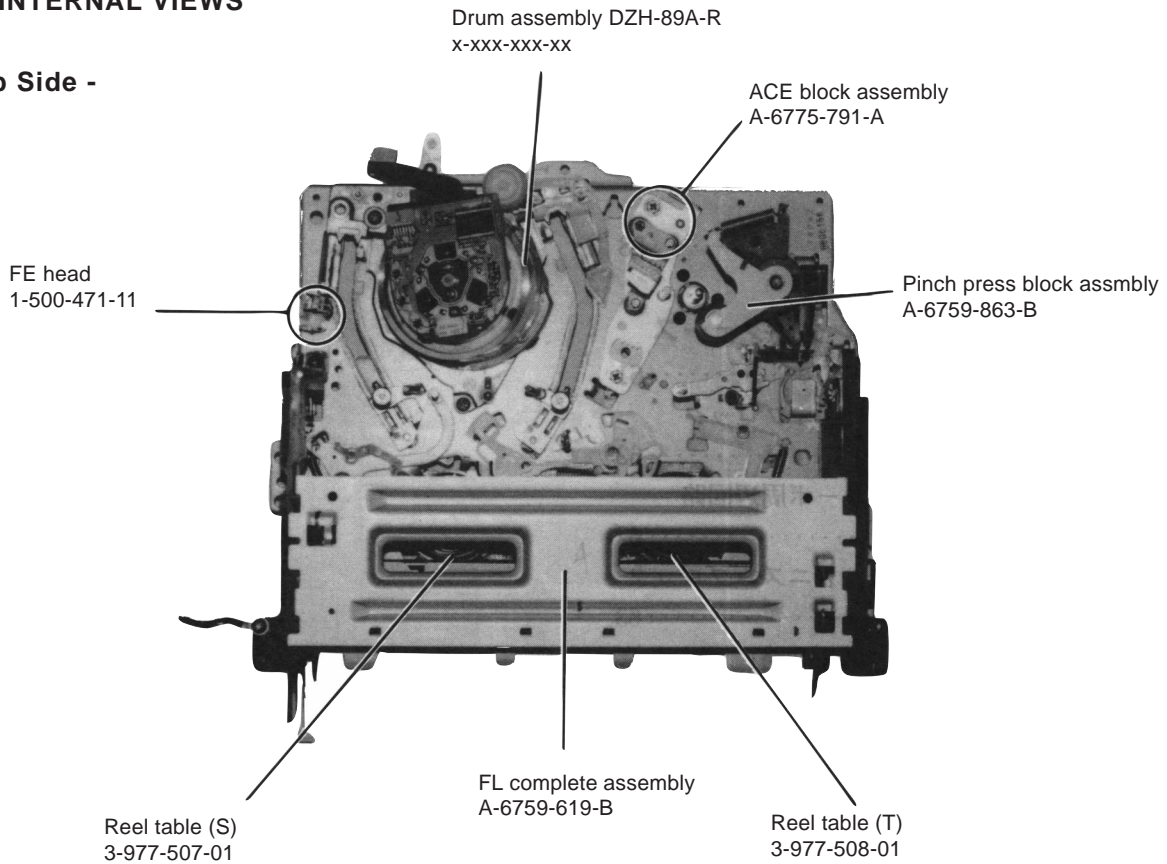

- Bottom Side -

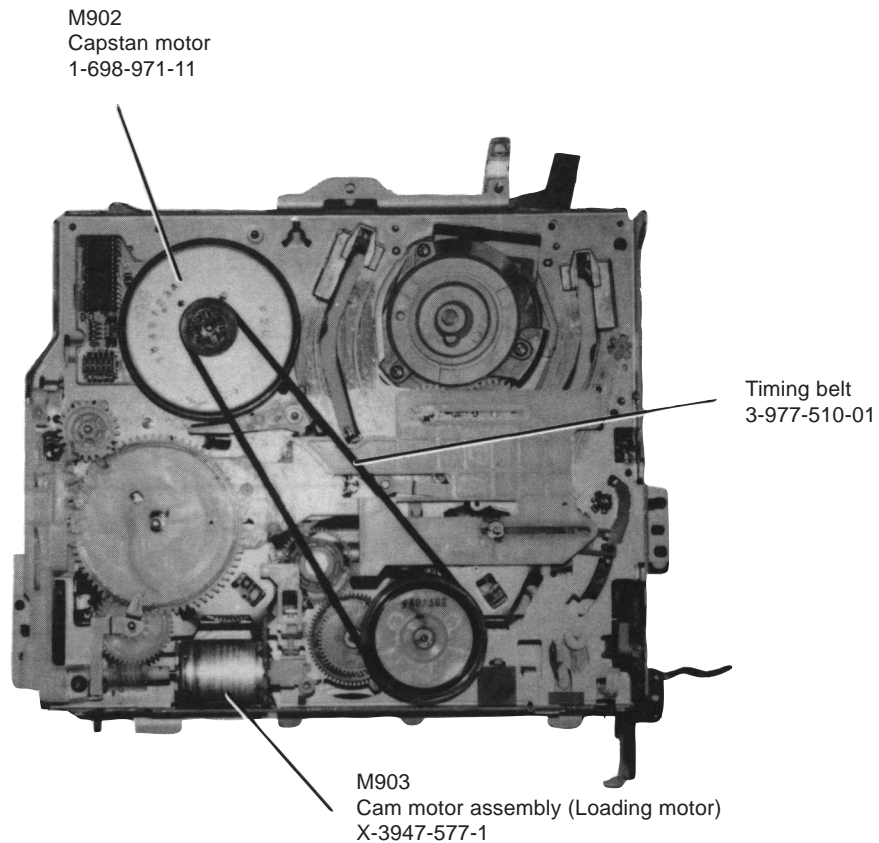

## SECTION 2 DISASSEMBLY

### 2-1. TOP COVER REMOVAL

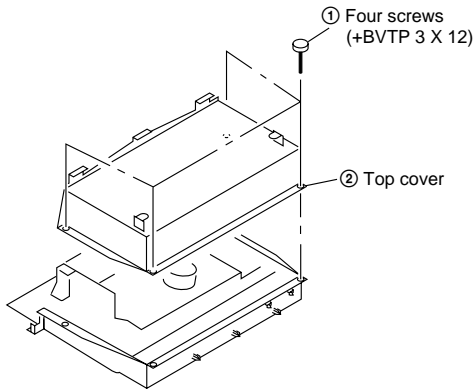

### 2-2. VCR BLOCK ASSY REMOVAL

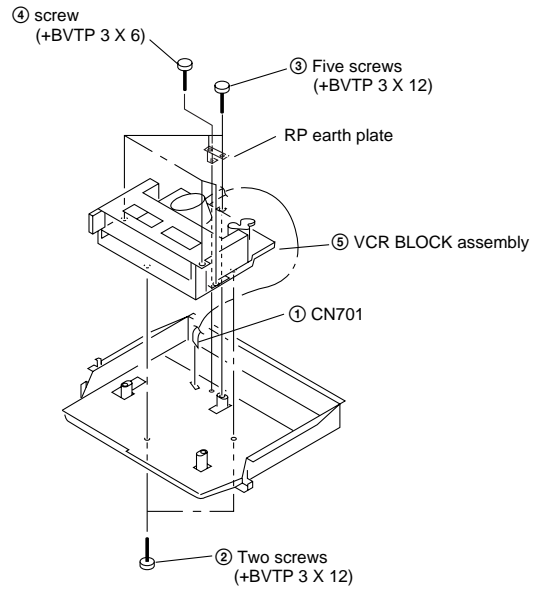

### 2-3. H10 BOARD REMOVAL

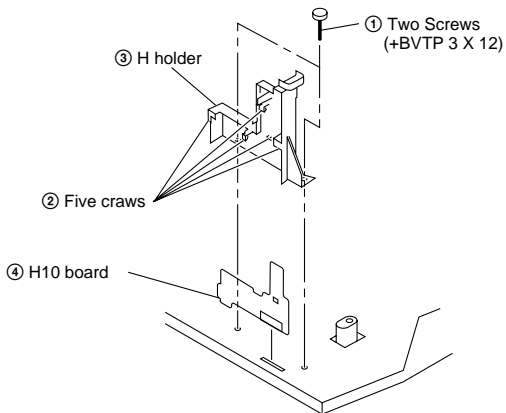

### 2-4. MA10 BOARD REMOVAL

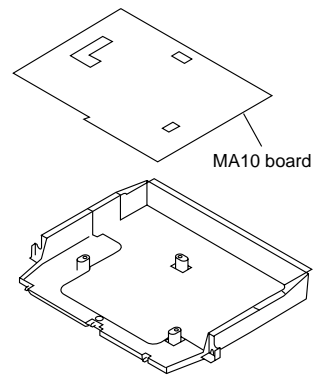

### 2-5. SERVICE POSITION (MA10 BOARD)

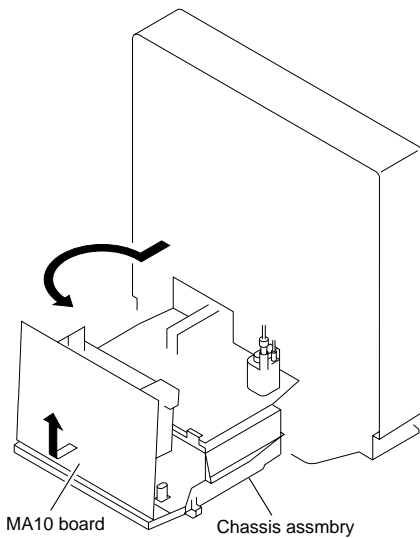

## SECTION 3 CIRCUIT ADJUSTMENTS

Necessary items and indications for total adjustment of electric circuit of this unit will be described in this chapter.

### [ INSTRUMENTS TO BE USED ]

- 1) Color TV
- 2) Signal or dual trace type oscilloscope, band more than 30 MHz, delay, as provided.
- 3) Frequency counter (4 digits or more)
- 4) PAL pattern generator
- 5) Digital voltmeter
- 6) Audio level meter
- 7) Audio generator
- 8) Attenuator
- 9) Distortion meter
- 10) Alignment tape

Part code : H7099052H (MH-2)

### [ CONNECTION ]

Unless otherwise specified, connect and adjust the measurement equipment as follows.

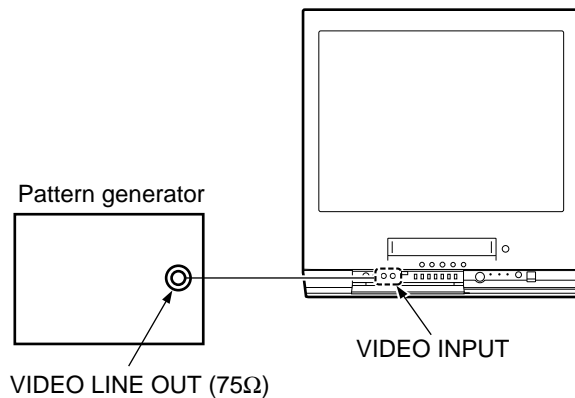

**Fig.3-1**

### [ SET-UP FOR ADJUSTMENT ]

The video signal from the pattern generator is used as adjustment signal for electrical adjustment. This video signal should meet the requirement. Connect the oscilloscope to the video input terminal on the MF 1 board and make sure that the amplitudes of sync signal of video signal, video portion and burst signal are flat at approximately 0.3, 0.7 and 0.3 V, respectively, and that the level ratio of the burst signal and "red signal" are 0.30 : 0.66, Fig.3-2 shows video signals (color bars) used in adjusting the electrical adjustment.

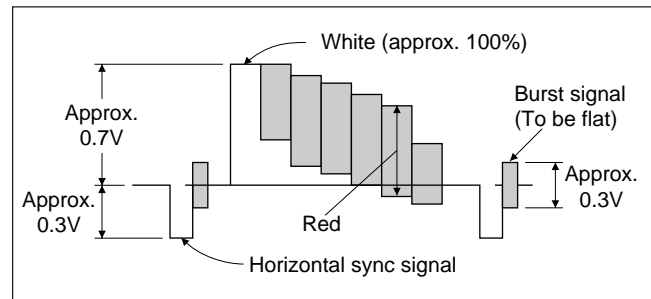

**Fig.3-2**

### Alignment Tape (MH-2)

	Time	Video signal	Audio signal
1	10 minutes	Starir-step	6kHz
2	5 minutes	-	3kHz
3	10 minutes	Color bar	1kHz
4	3 minutes	RF sweep	-

### [ SPECIFIED INPUT/OUTPUT LEVEL IMPEDANCE ]

#### Input/Output terminal

Video input	Pin jack Input signal : 1Vp-p, 75 , unbalanced Sync negative
AUDIO LINE IN	Pin jack Input level : -7.5dBs (0dBs=0.775Vrms) Input impedance : More than 47k

### X'tal OSC CHECK

Mode	PB
Signal	Alignment tape, Stair step
Measurement Point	MA10 board IC802 ②⑨pin(PAL)
Measurement Equipment	Oscilloscope
Specified Value	500±200mVp-p

**Check:** 1)Confirm the frequency is 4.433619MHz±100Hz(PAL).  
2)Confirm the waveform amplitude is 500±200mVp-p.

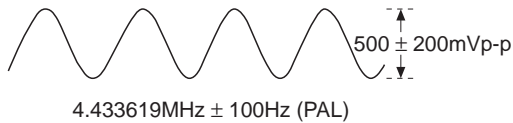

Fig.3-3

### CARRIER DEVIATION CHECK

Mode	E-E
Signal	Color bar
Measurement Point	MA10 board IC802 ①⑩pin
Measurement Equipment	Spectrum Analyzer
Specified Value	$f_2-f_1=1.00\pm 0.08\text{MHz}$

**Check:** Confirm  $f_2-f_1=1.00\pm 0.08\text{MHz}$   
Confirm  $f_1=3.80\pm 0.13\text{MHz(PAL)}$

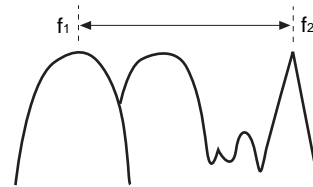

Fig.3-5

### SYNC AGC CHECK

Mode	E-E
Signal	Color bar
Measurement Point	MA10 board Q830 emitter
Measurement Equipment	Oscilloscope
Specified Value	1.0±0.1Vp-p

**Check:** Confirm the waveform amplitude is 1.0±0.1Vp-p.

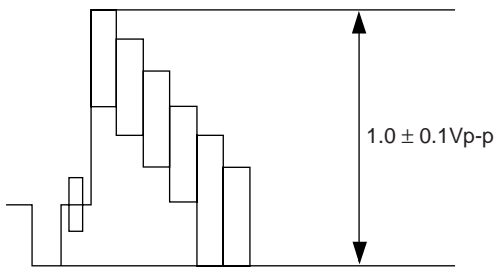

Fig.3-4

### WHITE/DARK CLIP CHECK

Mode	E-E
Signal	Color bar
Measurement Point	MA10 board IC802 ③⑦pin
Measurement Equipment	Oscilloscope
Specified Value	190±20% (White), 55±20% (Dark)

Preparation: Add 3.3k resistor between IC802 ④②pin and GND.

**Check:** Taking the height from sync to white level as 100%, check white clip and dark clip.

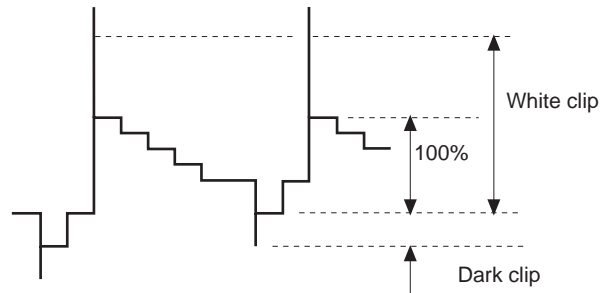

Fig.3-6

### REC Y LEVEL CHECK

Mode	E-E(SP)
Signal	No signal
Measurement Point	MA10 board IC802 ⑱pin
Measurement Equipment	Oscilloscope
Specified Value	$260 \pm 70 \text{mVp-p(PAL)}$

**Check:** Confirm the  $V_{p-p}$  of the waveform is  $220 \pm 70 \text{mVp-p}$ .

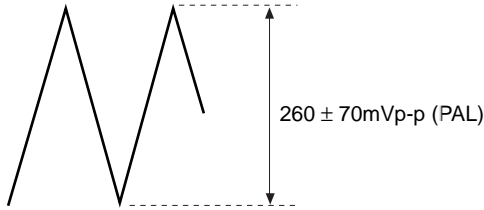

Fig.3-7

### PB Y LEVEL CHECK

Mode	PB
Signal	Color bar
Measurement Point	MA10 board Q830 emitter
Measurement Equipment	Oscilloscope
Specified Value	$1.0 \pm 0.1 \text{Vp-p}$

**Check:** Confirm the  $V_{p-p}$  of the waveform is  $1.0 \pm 0.1 \text{Vp-p}$ .

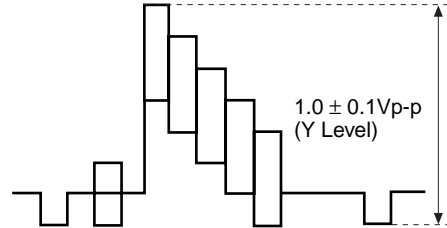

Fig.3-9

### REC CHROMA CHECK

Mode	REC(SP)
Signal	Color bar
Measurement Point	MA10 board IC802 ⑲pin
Measurement Equipment	Oscilloscope
Specified Value	$350 \pm 60 \text{mVp-p(PAL)}$

**Check:** Confirm the  $V_{p-p}$  of the waveform is  $350 \pm 60 \text{mVp-p}$ .

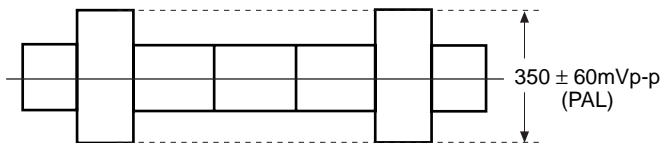

Fig.3-8

### HALF H SHIFT CHECK

Mode	EE
Signal	No signal
Measurement Point	MA10 board IC802 ⑲pin
Measurement Equipment	Spectrum Analyzer
Specified Value	$8.2 \pm 2 \text{kHz}$

**Check:** Confirm the  $1/2f_H$  of the waveform is  $8.2 \pm 2 \text{kHz}$ .

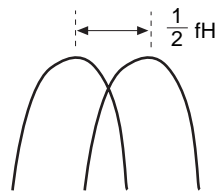

Fig.3-10

## SECTION 4

### INTERFACE, IC PIN FUNCTION DESCRIPTION

#### 4-1. $\mu$ -COM PORT FUNCTION DESCRIPTION (MA10 BOARD IC001)

Pin No.	Signal	I/O	Function
1	S SEL F	I	S-INPUT SELECT (FRONT)
2	S SEL R	I	S-INPUT SELECT (REAR)
3	ST	I	TU STEREO MODE
4	BIL	I	TU BILINGUAL MODE
5	DGC SW	-	DGC ON/OFF CONTROL
6	ST/ MONO	I	SET MODE STEREO/MONO
7	-	-	
8	MAIN /SUB	O	TU MAIN/SUB CONTROL
9	F MONO	O	TU FOCE MONO CONTROL
10	VM SW	O	VM ON/OFF CONTROL
11	GP A	I	"REC PON" SW A
12	GP B	I	"REC PON" SW B
13	GP C	I	"REC PON" SW C
14	ASURA CS	O	CHIP SELECT FOR ASURA
15	SLAVE RESE	O	RESET FOR ASURA
16	J CLK	O	JUST CLOCK DISABLE ("H" : DISAB)
17	FACT	I	FACTORY MODE
18	1TU /2TU	I	SET MODE 1TU/2TU
19	JUST CLOCK	I	JUST CLOCK DET INPUT
20	SIRCS	I	REMOCON SIGNAL IN
21	HSYNC 1	I	H SYNC DET INPUT (REC)
22	HSYNC 0	I	H SYNC DET INPUT (TV)
23	SI	I	SIGNAL DATA INPUT
24	SO	O	SIGNAL DATA OUTPUT
25	SCK	O	SIGNAL CLOCK OUTPUT
26	Vss	-	
27	B INT	I	BUS INT
28	X TAL	-	
29	EXTAL	-	
30	RESET	-	
31	A MUTE	O	AUDIO MUTE
32	CLK OS	O	CHIP SELECT FOR RT CLOCK
33	KEY2	I	KEY SCAN 2
34	KEY1	I	KEY SCAN 1
35	AFT1	I	AFT DET 1
36	AFT0	I	AFT DET 0
37	OVP	I	OVP DET
38	G SW	I	"REC PON" SW
39	XLC	-	
40	EXLC	-	
41	OSD R	-	
42	OSD G	-	
43	OSD B	-	
44	I	-	
45	YS	-	
46	YM	-	
47	SDA1	O	1 <sup>2</sup> C BUS DATA FOR YCJ etc
48	SDA0	O	1 <sup>2</sup> C BUS DATA FOR NVM
49	SCL1	O	1 <sup>2</sup> C BUS CHECK FOR YCJ etc
50	SCL0	O	1 <sup>2</sup> C BUS CHECK FOR NVM
51	LED2	O	POWER LED
52	LED1	O	STBY LED
53	NS	O	NS COIL CONTROL (PWM)
54	VOL	O	VOLUME CONTROL (PWM)
55	MP	-	
56	NC	-	
57	Vdd	-	
58	Vss	-	
59	HPULSE	I	
60	VPULSE	I	
61	CRTPOW	O	CRT POWER ON
62	VCRPOW	O	VCR POWER ON
63	M SW	I	MAIN SW
64	SP MUTE	O	SPEAKER MUTE

#### 4-2. SYSTEM CONTROL-VIDEO BLOCK INTERFACE (MA10 BOARD IC402)

Signal	Pin No.	I/O	STOP	FF	REW	TAPE THREADING	TAPE UNTHREADING	PB	PB · PAUSE	SLOW	X2	PICTURE SEARCH		REC	REC · PAUSE
												CUE	REVIEW		
RF SW P (SW30)	IC402 ①	O	*1	*1	*1	*1	*1	*1	*1	*1	*1	*1	*1	*1	*1
Q VD	IC402 ④	O	L	L	L	L	L	*2	*3	*3	*3	*3	*3	L	L
V SYNC	IC402 ⑥	I	*4	*4	*4	*5	*5	*5	*5	*5	*5	*5	*5	*5	*5

- \*1. 30Hz 50% duty pulse synchronizing with drum rotation.
- \*2. Normally "L" . "H" when the video signal is not detected.
- \*3. V period "H" pulse.
- \*4. "H" in the LP mode. Selected according to the recording mode.
- \*5. Selected according to the tape recording mode.

#### 4-3. SYSTEM CONTROL-SERVO PERIPHERAL CIRCUIT INTERFACE (MA10 BOARD IC402)

Signal	Pin No.	I/O	STOP	FF	REW	TAPE THREADING	TAPE UNTHREADING	PB	PB · PAUSE	SLOW	X2	PICTURE SEARCH		REC	REC · PAUSE
												CUE	REVIEW		
REC CTL	IC402 ⑦	O	HI-Z	HI-Z	HI-Z	HI-Z	HI-Z	HI-Z	HI-Z	HI-Z	HI-Z	HI-Z	HI-Z	*1	HI-Z
CAP STOP	IC402 ⑭	O (O.D)	L	HI-Z (O.D)	HI-Z (O.D)	HI-Z (O.D)	HI-Z (O.D)	HI-Z (O.D)	L	*3	HI-Z (O.D)	HI-Z (O.D)	HI-Z (O.D)	HI-Z (O.D)	HI-Z (O.D)
STEP PLS	IC402 ⑱	O	L	L	L	L	L	L	L	*2	L	L	L	L	L
PB CTL	IC402 ⑲	I	H	*6	*6			*1	H/L	*2	*6	*6	*6	*1	H
DRUM PG	IC402 ⑳	I	*4	*1	*1	*5	*5	*1	*1	*1	*1	*1	*1	*1	*1
DRUM FG	IC402 ㉑	I	*4	*7	*7	*5	*5	*7	*7	*7	*7	*7	*7	*7	*7
CAP FG	IC402 ㉒	I	H/L	*6	*6	*5	*5	*6	H/L	*2	*6	*6	*6	*6	H/L
CAP DA	IC402 ㉓	O	*8	*8	*8	*8	*8	*9	*8	*8	*9	*9	*9	*9	*8
DRUM DA	IC402 ㉔	O	*10	*10	*10	*10	*10	*10	*10	*10	*10	*10	*10	*10	*10
CTL RESET	IC402 ㉕	I/O	HI-Z	HI-Z	HI-Z	HI-Z	HI-Z	HI-Z	HI-Z	*11	HI-Z	HI-Z	HI-Z	HI-Z	HI-Z

- \*1. 30Hz 50% pulse.
- \*2. Pulse in tape running.
- \*3. Reverse logic pulse of STEP PLS.
- \*4. "L" when drum rotation stops.
- \*5. Unstable period pulse.
- \*6. Pulse of Period proportionate to tape speed.
- \*7. 360Hz pulse.
- \*8. Pulse in tape running.
- \*9. Approx. 2 msec. period "H" or "L" pulse.
- \*10. Approx. 1.5 msec. period "H" or "L" pulse.



#### 4-4. SYSTEM CONTROL-MECHANISM BLOCK INTERFACE (MA10 BOARD IC402)

Signal	Pin No.	I/O	EJECTED	CASSETTE		TAPE		STOP	FF	REW	PB	PB · PAUSE	SLOW	X2	PICTURE SEARCH		REC	REC · PAUSE
				LOADING	UNLOADING	THREADING	UNTHREADING								CUE	REVIEW		
CAM UN LOAD	IC402 ⑨	O	HI-Z	H	L	H	L	*7	*7	*7	*7	*7	*7	*7	*7	*7	*7	*7
CAM LOAD	IC402 ⑩	O	L	L	L	L	L	L	L	L	L	L	L	L	L	L	L	L
MODE 1	IC402 ⑫	I	H	L	L	*1	*1	H	H	H	H	H	H	H	H	L	H	H
MODE 2	IC402 ⑬	I	H	L	L	*1	*1	H	H	H	L	L	L	L	L	L	L	L
MODE 3	IC402 ⑭	I	L	L	L	*1	*1	H	L	L	L	L	L	L	L	H	L	L
MODE 4	IC402 ⑮	I	L	H	H	*1	*1	L	H	H	L	L	L	L	L	L	L	L
C IN REC PRF	IC402 ⑰	I	L	*2	*2	*2	*2	*2	*2	*2	*2	*2	*2	*2	*2	*2	*2	*2
T REEL FG	IC402 ⑱	I	H/L	H/L	H/L	H/L	H/L	H/L	*3	*3	*3	H/L	*3	*3	*3	*3	*3	H/L
S REEL FG	IC402 ⑲	I	H/L	H/L	H/L	*3	*3	H/L	*3	*3	*3	H/L	*3	*3	*3	*3	*3	H/L
T/S LED	IC402 ㉑	O (O.D)	*4	*4	*4	*4	*4	*4	*4	*4	*4	*4	*4	*4	*4	*4	*4	*4
CAP STOP	IC402 ㉒	O (O.D)	L	L	L	H	H	L	H	H	H	L	*5	H	H	H	H	L
CAP RVS	IC402 ㉓	O	L			H	L	H/L	H	L	H	H	H/*5	H	H	L	H	H
T SENS	IC402 ㉔	I	*4	*4	*4	*6	*6	*6	*6	*6	*6	*6	*6	*6	*6	*6	*6	*6
S SENS	IC402 ㉕	I	*4	*4	*4	*6	*6	*6	*6	*6	*6	*6	*6	*6	*6	*6	*6	*6

\*1. Uncertainty.

\*2. "L" when the erasing protection tab is bent, "H" when not bent.

\*3. Pulse of period proportionate to reel rotation speed.

\*4. Apporx. 2 msec. period "H" pulse.

\*5. Pulse in tape running.

\*6. Normally "L". 2 msec. period "H" pulse when tape top or tape end is detected.

\*7. "L" when unloading to switchover. "H" when loading. "HI-Z" when CAM motor is stop.

#### 4-5. SYSTEM CONTROL-SYSTEM CONTROL PERIPHERAL CIRCUIT INTERFACE (MA10 BOARD IC402)

Signal	Pin No.	I/O	Function
ASURA RESET	IC402 ④	I	Normally "H". "L" when service interruption is detected or restored.
ASURA CS	IC402 ④	I	Chip select signal from the timer microprocessor. V period "L" pulse.
S IN 0	IC402 ⑤	I	Serial communication data from the timer microprocessor. V period "L" pulse.
S OUT 0	IC402 ⑥	O	Serial communication data to the timer microprocessor. V period "L" pulse.
S CLK	IC402 ⑦	I	Serial communication clock with the timer microprocessor. V period "L" pulse.

#### 4-6. SYSTEM CONTROL-AUDIO BLOCK INTERFACE (MA10 BOARD IC402)

Signal	Pin No.	I/O	STOP	FF	REW	TAPE LOADING	TAPE UNLOADING	PB	PB · PAUSE	SLOW	X2	PICTURE SEARCH		REC	REC · PAUSE
												CUE	REVIEW		
A MUTE	IC402 ⑩	O (O.D)	L	L	L	L	L	*1	H	H	H	H	H	L	L

\*1. 30Hz 50% duty pulse approximately 5 msec. delayed from RF SW P.

#### 4-7. SERVO/SYSTEM CONTROL PORT FUNCTION DESCRIPTION (MA10 BOARD IC402)

Pin No.	Signal	I/O	Function
1	RF SWP	O	RF SWITCHING PULSE
2	-	-	
3	-	-	
4	QVD	O	QUASI VD
5	CTLHYS HIGH	O	CTL CONTROL
6	-	-	
7	REC CTL	O	REC CTL SIGNAL
8	CAM LOAD	O	CAM LOADING
9	CAM UNLOAD	O	CAM UNLOADING
10	CTL RESET	O	CTL CONTROL
11	-	-	
12	-	-	
13	-	-	
14	-	-	
15	-	-	
16	-	-	
17	C IN	I	CASSETTE IN
18	-	-	
19	MODE4	I	MD MODE DET
20	MODE3	I	MD MODE DET
21	MODE2	I	MD MODE DET
22	MODE1	I	MD MODE DET
23	LED6	O	REC PON LED
24	LED5	O	ON TIMER LED
25	LED4	O	REC LED
26	LED3	O	TIMER REC LED
27	-	-	
28	SDA	I/O	I <sup>2</sup> C BUS DATA FOR VIDEO/HIFI
29	-	-	
30	SCL	O	I <sup>2</sup> C BUS CLOCK FOR VIDEO/HIFI
31	-	-	
32	-	-	
33	GND	O	
34	CAP STOP	O	
35	T/S LED	O	T/S LED CONTROL
36	GND	O	
37	GND	O	
38	GND	O	
39	MP	-	
40	ASURA RESET	-	
41	Vss	-	
42	XTAL	-	
43	EXTAL	-	
44	ASURA CS	I	ASURA u-COM CHIP SELECT
45	S IN 0	I	SERIAL DATA IN
46	S OUT 0	O	SERIAL DATA OUT
47	S CLK	I	SERIAL CLOCK
48	GND	O	
49	MUTE	O	AUDIO MUTE
50	POS	I	SWITCHING POSITION ADJ MODE

Pin No.	Signal	I/O	Function
51	GND	O	
52	AVss	-	
53	AV ref	-	
54	AVdd	-	
55	SECAM/SVHS	I	SVHS DET IN
56	GND	O	
57	DEW	I	DEW SENSOR
58	GND	O	
59	-	-	
60	RF ENV	I	VIDEO RF ENVELOPE DET
61	T SENS	I	TAPE TOP SENSOR
62	S SENS	I	TAPE END SENSOR
63	SREEL FG	I	S-REEL FG
64	TREEL FG	I	T-REEL FG
65	GND	O	
66	VSYNC	I	V SYNC SIGNAL IN
67	PB CTL	I	PB CTL SIGNAL
68	DRM PG	I	DRUM PG
69	DRM FG	I	DRUM FG
70	CAP FG	I	CAPSTAN FG
71	-	-	
72	CAP RVS	O	CAPSTAN REVERSE
73	CAP DA	O	CAPSTAN D/A OUTPUT
74	DRM DA	O	DRUM D/A OUTPUT
75	JOG	O	JOG CONTROL
76	S VHS	O	S VHS DET OUT
77	REC COUNT	I	REC CTL COUNT
78	-	-	
79	-	-	
80	SO 1	O	SERIAL DATA OUTPUT FOR RP AMP
81	SCK1	O	SERIAL CLOCK FOR RP AMP
82	GND	O	
83	V PB	O	VIDEO PB MODE
84	CAP PWM	O	CAPSTAN
85	-	-	
86	-	-	
87	-	-	
88	Vss	-	
89	Vdd	-	
90	-	-	
91	-	-	
92	-	-	
93	-	-	
94	-	-	
95	-	-	
96	-	-	
97	-	-	
98	-	-	
99	STEP PLS	O	
100	-	-	

SECTION 5  
DIAGRAMS

5-1. BLOCK DIAGRAMS

VIDEO BLOCK

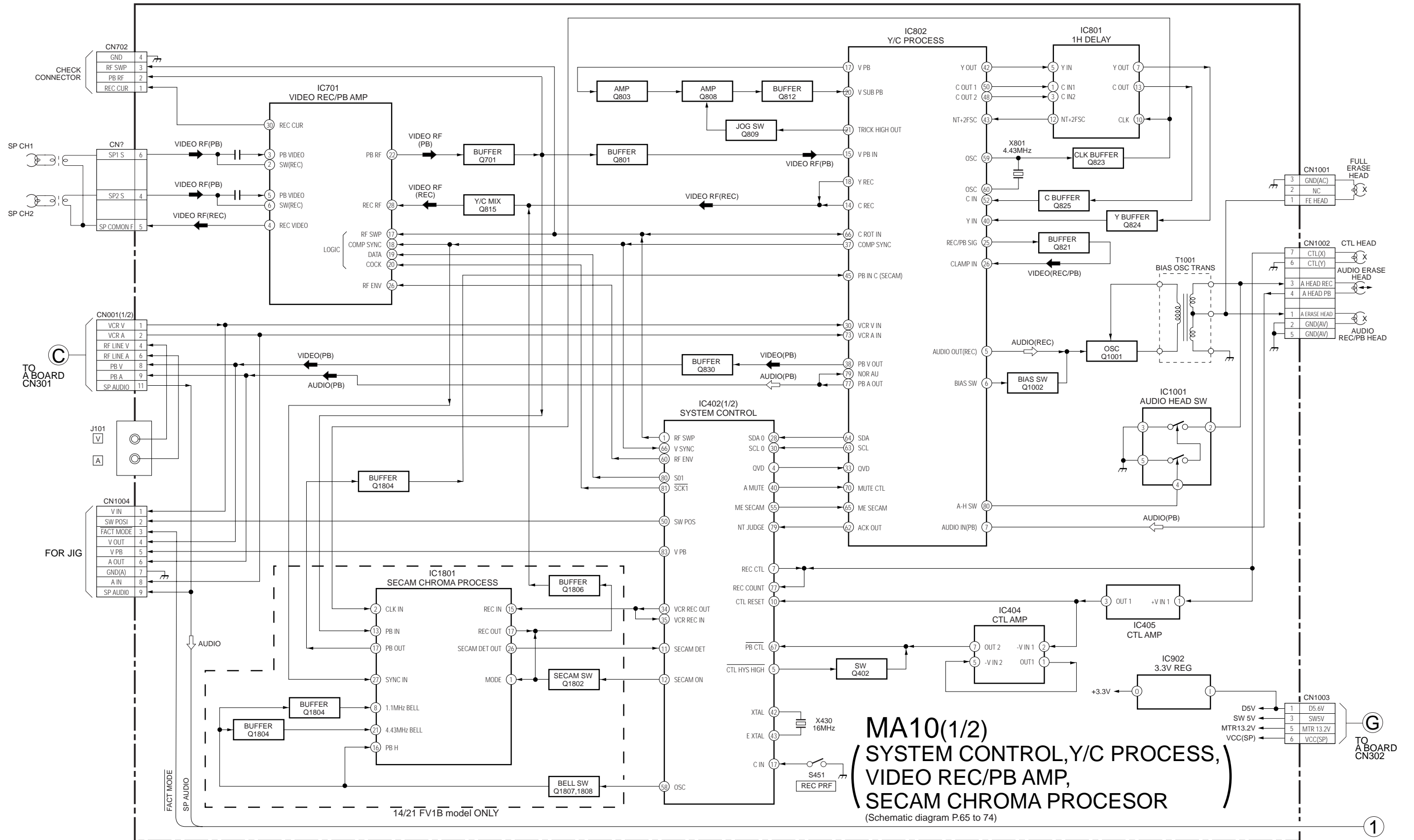



## 5-2. CIRCUIT BOARDS LOCATION

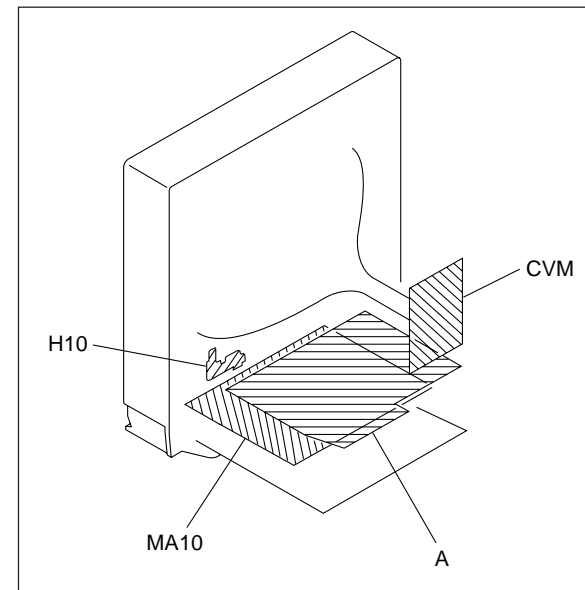

## 5-3. PRINTED WIRING BOARDS AND SCHEMATIC DIAGRAMS

### Note:

- All capacitors are in  $\mu\text{F}$  unless otherwise noted. pF:  $\mu\text{F}$   
Capacitors without voltage indication are all 50V.
- All resistors are in ohms.  
k = 1000, M = 1000k
- Indication of resistance, which does not have one for rating electrical power, is as follows.

Pitch: 5 mm  
Rating electrical power: 1/4W(CHIP:1/10W)

- : nonflammable resistor.
- : fusible resistor.
- $\Delta$  : internal component.
- : panel designation and adjustment for repair.
- All variable and adjustable resistors have characteristic curve B, unless otherwise noted.
- $\#$  : earth-chassis.

- Readings are taken with a color-bar signal input.
- Readings are taken with a 10M digital multimeter.
- Voltage variations may be noted due to normal production tolerances.
- All voltages are in V.
- no mark : REC/PB  
( ) : REC  
< > : PB
- Circled numbers are waveform reference.
- : B + line
- : B - line.
- : signal path.

**Note:** The components identified by shading and mark  $\Delta$  are critical for safety. Replace only with part number specified.

### Reference information

RESISTOR	: RN	METAL FILM
	: RC	SOLID
	: FPRD	NONFRAMMABLE CARBON
	: FUSE	NONFRAMMABLE FUSIBLE
	: RW	NONFRAMMABLE WIREWOUND
	: RS	NONFRAMMABLE METAL OXIDE
	: RB	NONFRAMMABLE CEMENT
	: *	ADJUSTMENT RESISTOR
COIL	: LF-8L	MICRO INDUCTOR
CAPACITOR	: TA	TANTALUM
	: PS	STYROL
	: PP	POLYPROPYLENE
	: PT	MYLAR
	: MPS	METALIZED POLYESTER
	: MPP	METALIZED POLYPROPYLENE
	: ALB	BIPOLAR
	: ALT	HIGH TEMPERATURE
	: ALR	HIGH RIPPLE

### Terminal name of semiconductors in silk screen printed circuit (\* )

Device	Printed symbol	Terminal name	Circuit
① Transistor		Collector Base Emitter	
② Transistor		Collector Base Emitter	
③ Diode		Cathode Anode	
④ Diode		Cathode Anode (NC)	
⑤ Diode		Cathode Anode (NC)	
⑥ Diode		Common Anode Cathode	
⑦ Diode		Common Anode Cathode	

(Chip semiconductors that are not actually used are included.)

Ver.1.6

**Note:** Les composants identifiés par la marque  $\Delta$  sont critiques pour la sécurité. Ne les remplacer que par une pièce portant le numéro spécifié.

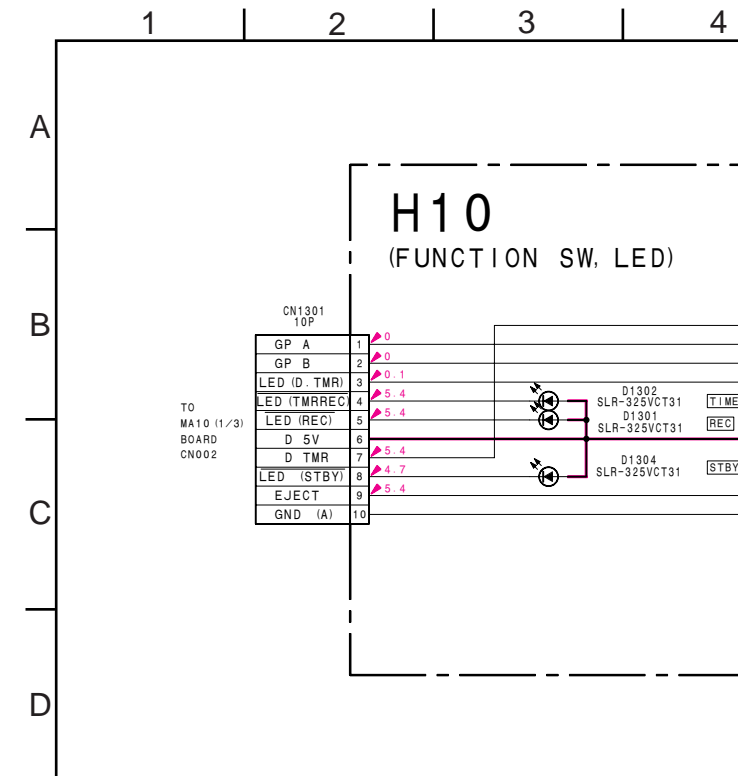

3 | 4 | 5 | 6

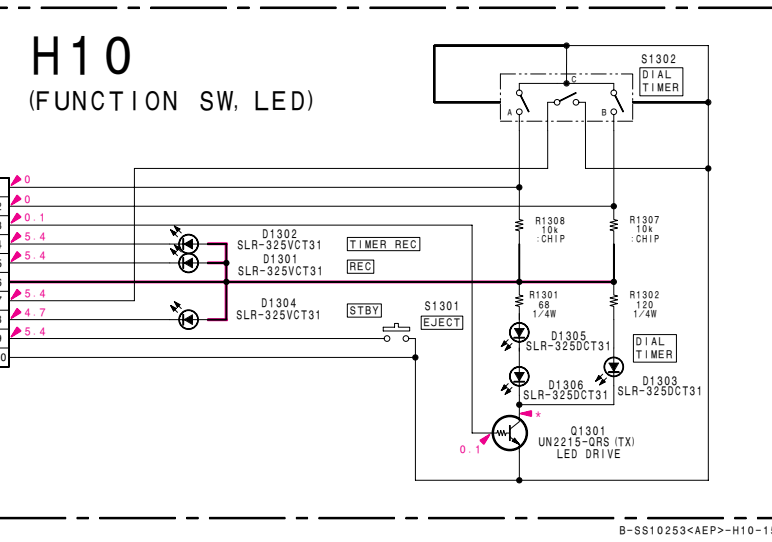

## H10

[FUNCTION SW, LED]

– H10 BOARD –

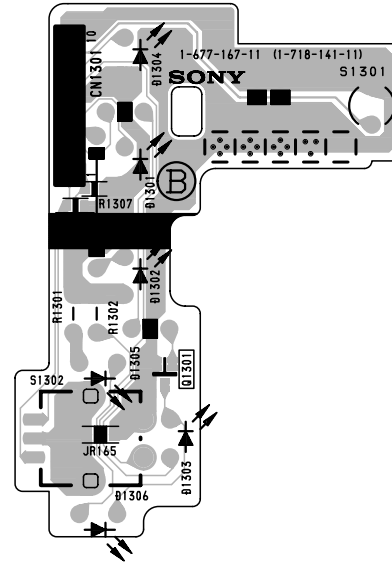

# MA10 (1/3)

[SYSTEM CONTROL, MAIN MICON]  
[VCR SERVO, AUDIO]

# MA10 (2/3)

[Y/C PROCESS, SECAM CHROMA PROCESS]

# MA10 (3/3)

[AC IN, VIDEO REC/PB AMP]

## - MA10 BOARD -

### MA10 BOARD

IC				
IC001	C-6	Q904	J-8	①
IC002	B-6	Q1001	A-2	-
IC003	C-7	Q1002	B-2	①
IC005	J-4	Q1801	G-3	①
IC201	K-2	Q1802	H-2	①
IC252	A-4	Q1804	H-2	①
IC401	D-7	Q1805	G-2	①
IC402	G-7	Q1806	H-2	①
IC403	E-4	Q1807	G-3	①
IC404	A-3	Q1808	G-3	①
IC405	A-3	<b>DIODE</b>		
IC701	J-2	D001	C-5	*
IC801	E-2	D002	B-6	-
IC802	C-3	D004	B-7	-
IC901	I-7	D005	B-8	-
IC902	I-8	D006	C-8	-
IC1001	B-1	D007	B-8	-
IC1101	A-9	D008	B-6	-
IC1801	F-2	D009	-	-
<b>TRANSISTOR</b>		D201	A-7	-
Q003	B-7	D202	A-7	-
Q005	C-4	D251	A-4	-
Q006	C-4	D252	B-4	-
Q008	C-5	D253	B-4	-
Q009	C-8	D254	B-4	-
Q201	L-3	D402	E-4	-
Q402	A-4	D403	E-7	-
Q451	G-6	D405	G-1	-
Q452	B-5	D406	B-5	-
Q453	J-5	D407	B-5	-
Q701	I-2	D432	F-7	-
Q801	F-4	D433	H-7	-
Q803	D-4	D451	F-5	-
Q808	D-4	D901	H-8	-
Q809	D-3	D902	J-7	-
Q812	D-4	D903	J-7	⑧
Q815	C-3	D904	J-7	-
Q821	D-3	D905	I-8	-
Q822	C-1	D1101	J-8	-
Q824	E-2	D1102	J-9	-
Q825	E-1	D1103	J-9	-
Q830	E-2	D1104	J-9	-
Q901	J-8	D1105	J-9	-
Q902	I-8	D1106	B-5	-
Q903	I-6	D1107	B-5	-
		D1108	A-5	-
		D1109	A-5	-
		D1110	B-9	-

\*: Refer to Terminal name of semiconductors  
in silk screen printed circuit (see page 59).

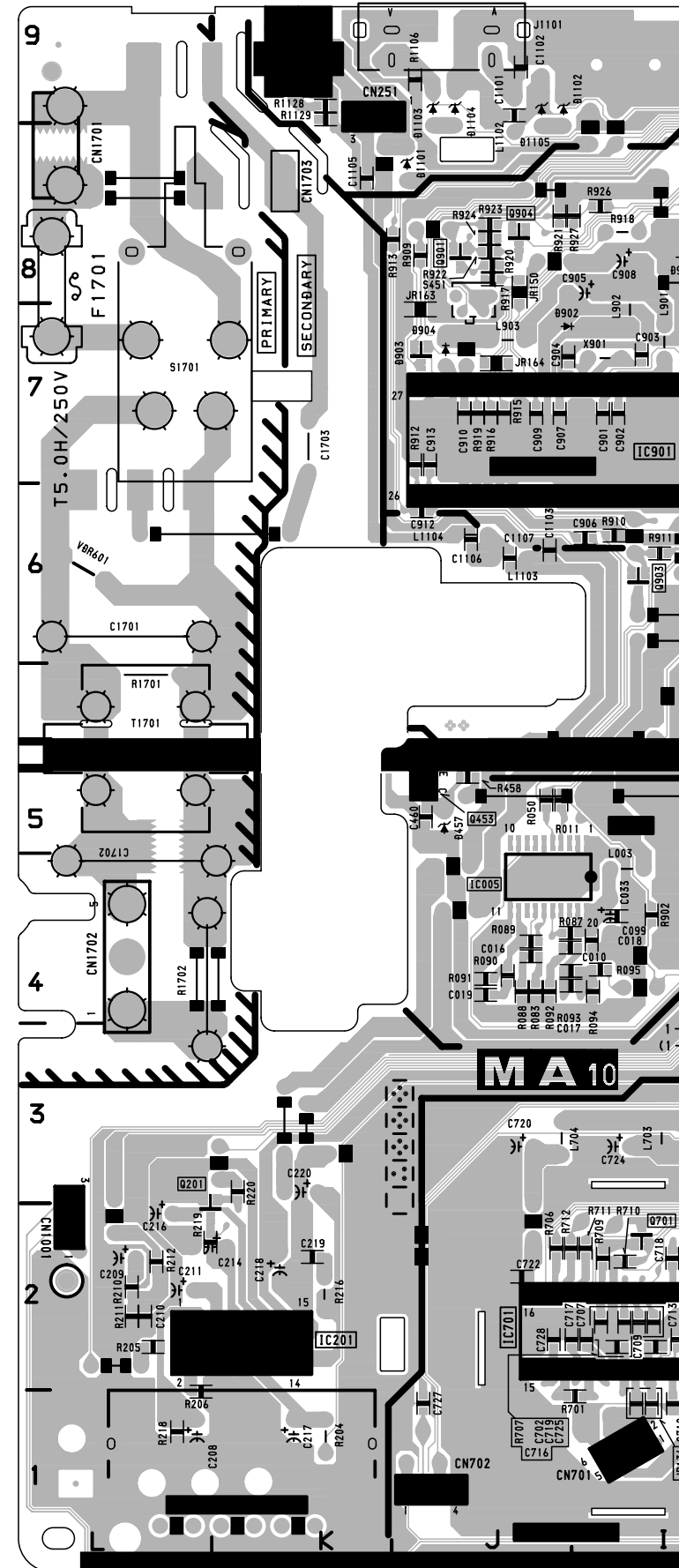

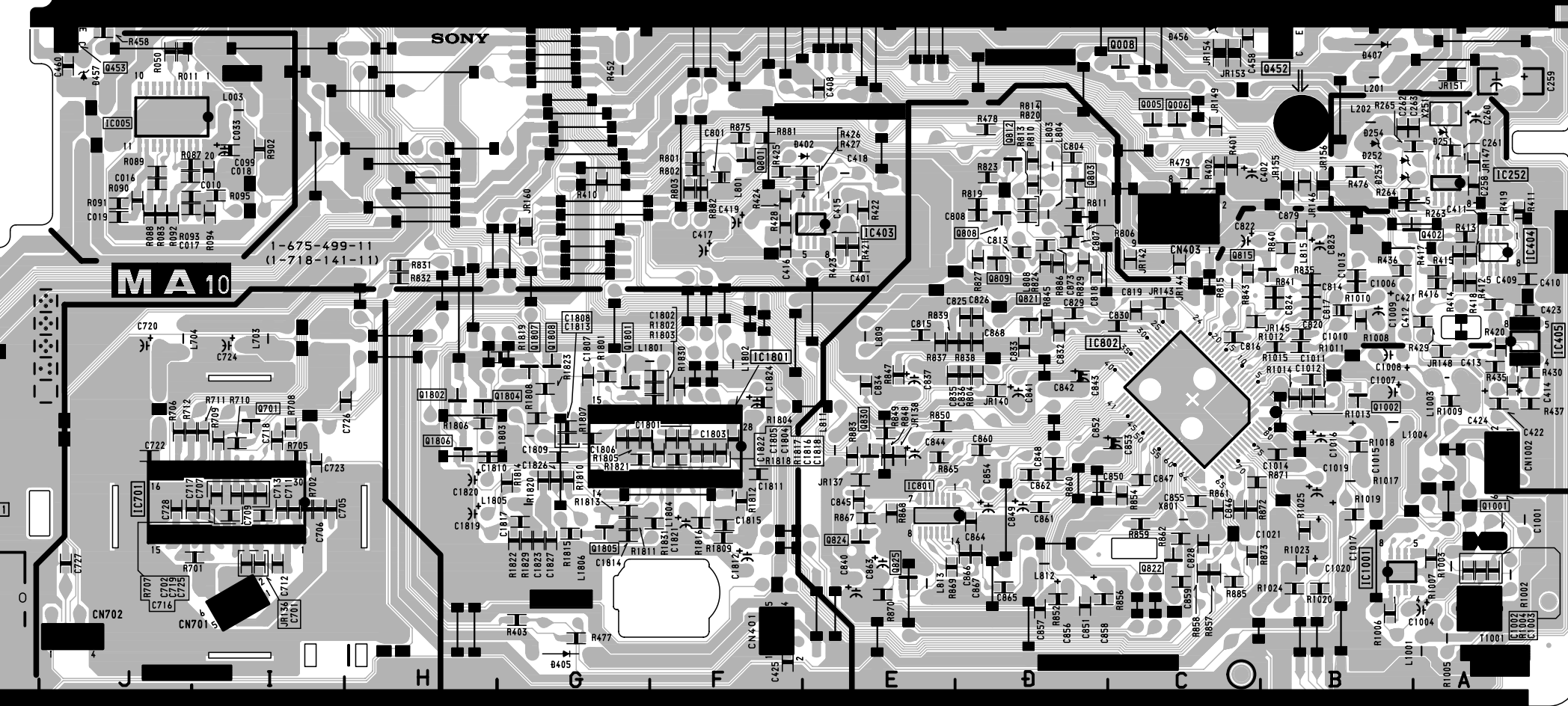
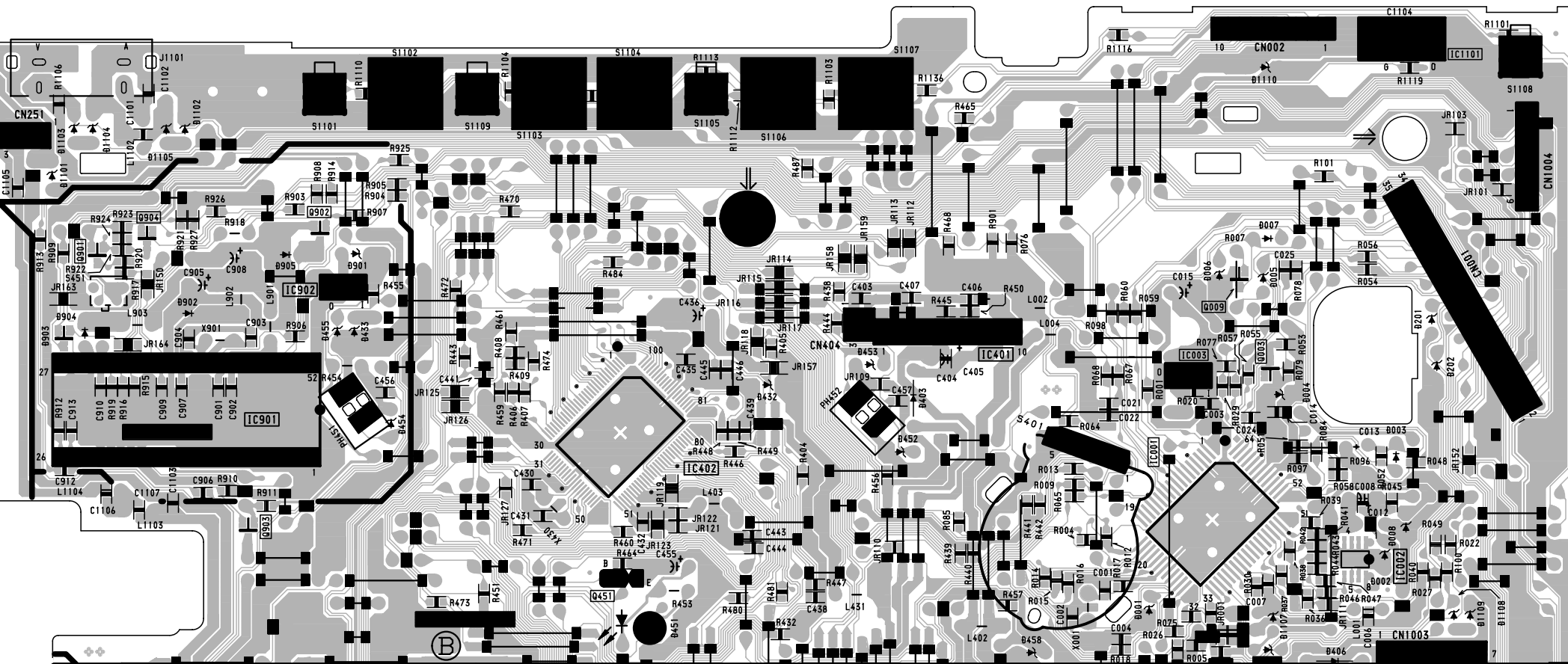



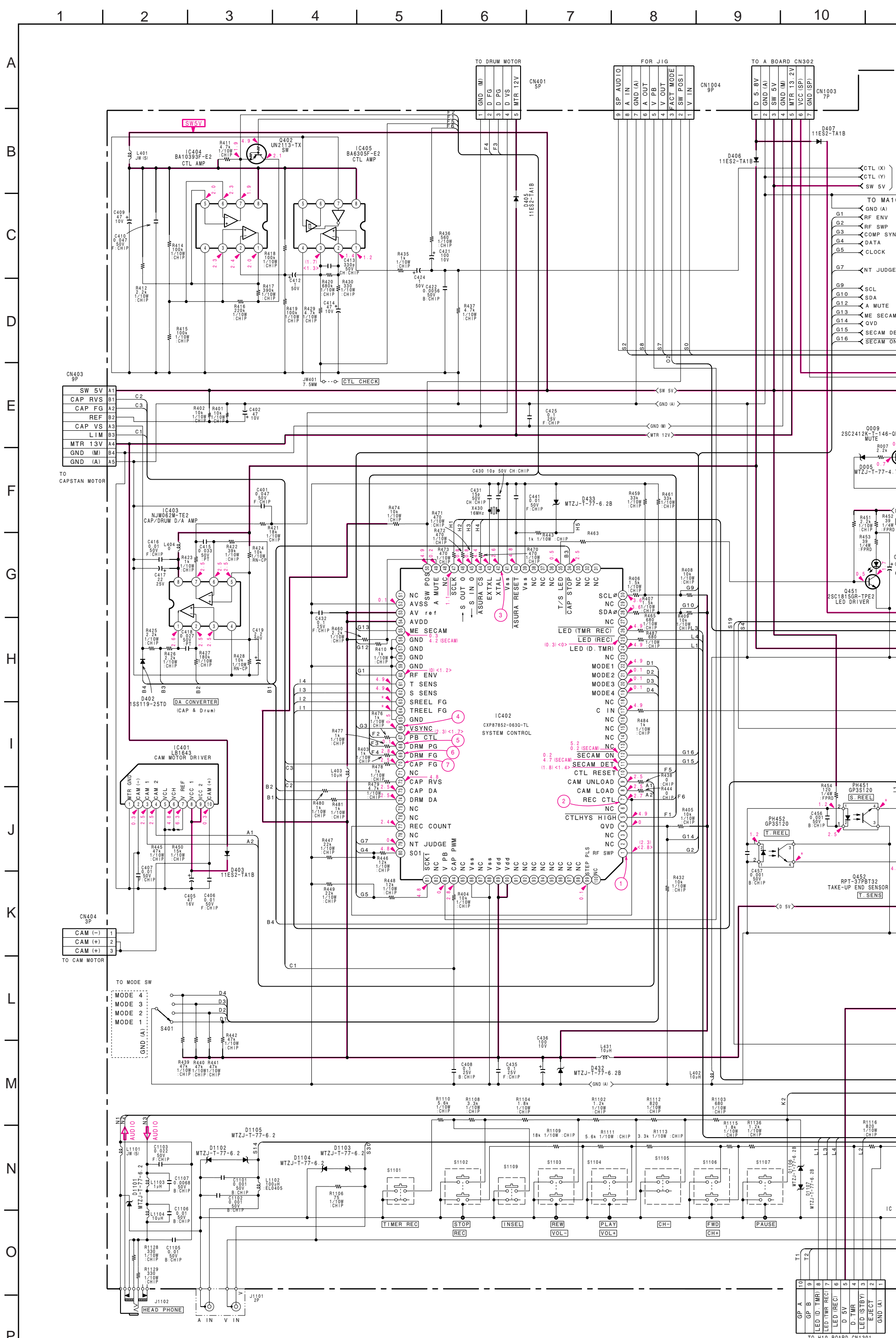

SW 5V	A1
CAP RVS	B1
CAP FG	A2
REF	B2
CAP VS	A3
LIM	B3
MTR 13V	A4
GND (M)	B4
GND (A)	A5

CAM (-)	1
CAM (+)	2
CAM (+)	3

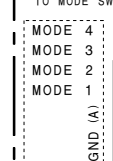

GP A	10
GP B	9
LED (D. TMR)	8
LED (D. REC)	7
D. 5V	6
D. TMR	5
LED (D. TMR)	4
EJECT	3
GND (A)	1

# MA10 (1/3) (SYSTEM CONTROL, MAIN μ-COM, VCR SERVO, A

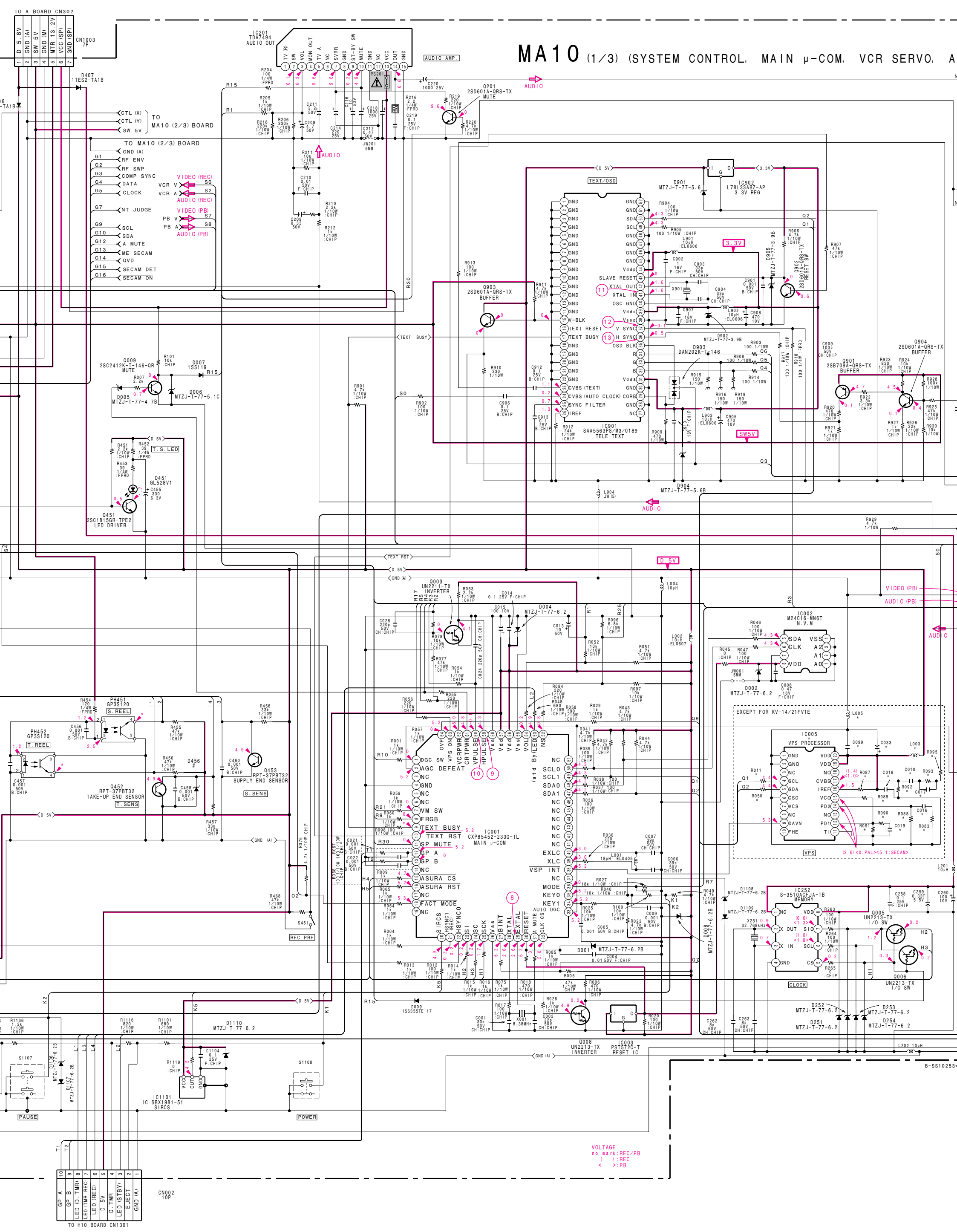

- TO MA10 (2/3) BOARD
- G1 GND (A)
  - G2 RF ENV
  - G3 RF SWP
  - G4 COMP SYNC
  - G5 DATA
  - G6 CLOCK
  - G7 NT JUDGE
  - G9 SCL
  - G10 SDA
  - G12 A MUTE
  - G13 ME SECAM
  - G14 QVD
  - G15 SECAM DET
  - G16 SECAM ON
- VIDEO (REC) S0
- VCR V S2
- AUDIO (REC) S7
- VIDEO (PB) S8
- PB V S7
- PB A S8
- AUDIO (PB)

- TO H10 BOARD CN1301
- T1 GP A
  - T2 GP B
  - T3 LED (O. TMR)
  - T4 LED (TMR REC)
  - T5 LED (REC)
  - T6 D. TMR
  - T7 LED (S. BY)
  - T8 EJECT
  - T9
  - T10 GND (A)

VOLTAGE  
no mark: REC/PB  
( ) : REC  
< > : PB

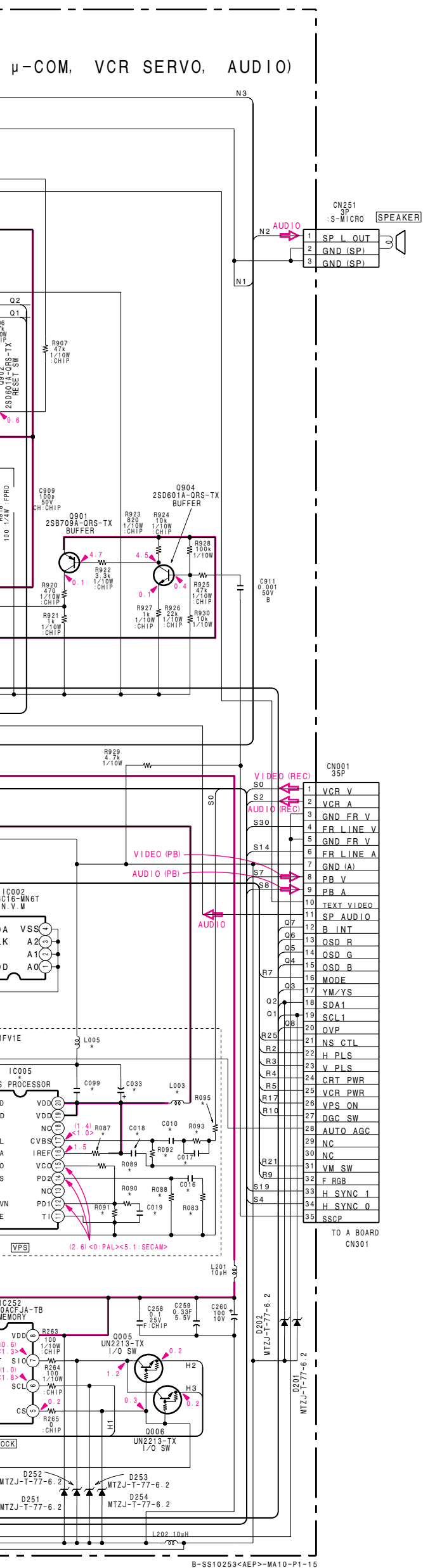

**MA10(1/3) BOARD \* MARK LIST**

Ref No.	FR/AEP/UK model	ESP model
C010	0.033 25V B:CHIP	—
C016	0.022 B:CHIP	—
C017	150p CH:CHIP	—
C018	0.047 25V B:CHIP	—
C019	0.033 25V B:CHIP	—
C033	100 10V	—
C099	0.1 25V F:CHIP	—
IC005	SDA5650X-GEG	—
L003	10μH	—
L005	JW(5)	—
R011	100 :CHIP	—
R050	100 :CHIP	—
R083	6.8k :CHIP	—
R087	100k :CHIP	—
R088	1.2M :CHIP	—
R089	100 :CHIP	—
R090	6.8k :CHIP	—
R091	1.2M :CHIP	—
R092	1M :CHIP	—
R093	2.2k :CHIP	—
R095	0 :CHIP	—

—: Not used

**MA10(1/3) BOARD WAVEFORMS**

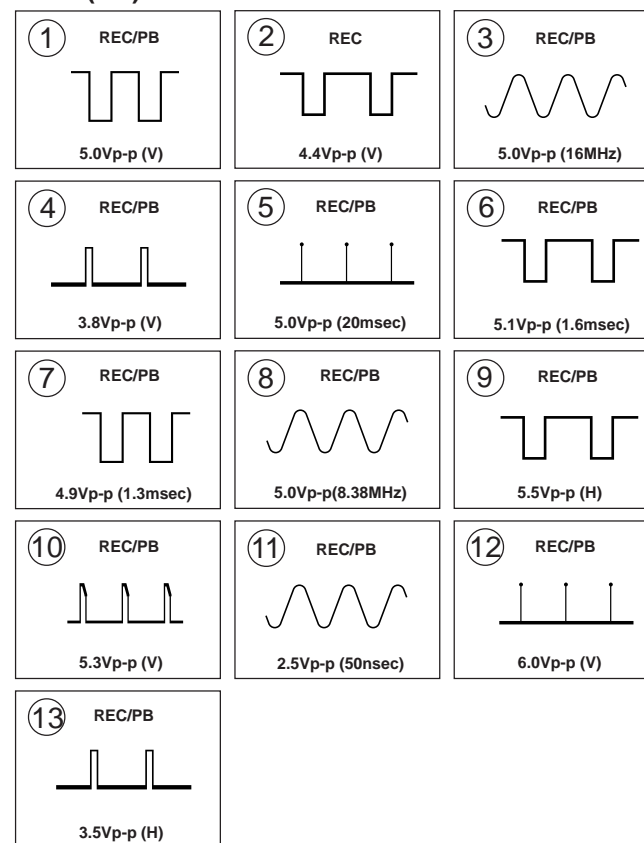

**MA10(2/3) BOARD WAVEFORMS**

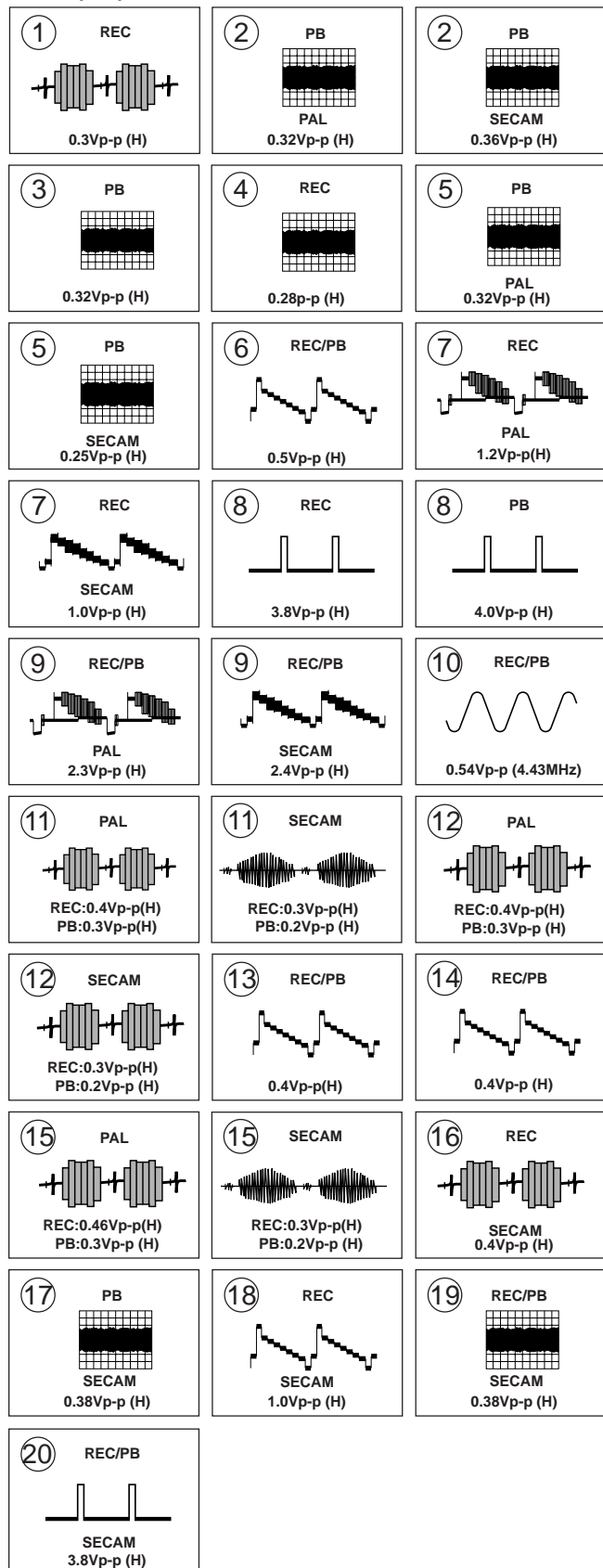

**MA10(2/3) BOARD \* MARK LIST**

Ref No.	FR model	AEP/UK/ESP model
C1801	0.01 B:CHIP	—
C1802	150p CH:CHIP	—
C1803	220p CH:CHIP	—
C1804	0.0047 B:CHIP	—
C1805	0.0047 B:CHIP	—
C1806	0.1 25V B:CHIP	—
C1807	0.01 B:CHIP	—
C1808	0.01 B:CHIP	—
C1809	0.001 B:CHIP	—
C1810	0.01 F:CHIP	—
C1811	0.01 F:CHIP	—
C1812	47 10V	—
C1813	82p CH:CHIP	—
C1814	680p CH:CHIP	—
C1815	0.01 B:CHIP	—
C1816	220p CH:CHIP	—
C1817	0.1 25V B:CHIP	—
C1818	0.022 B:CHIP	—
C1819	10	—
C1820	0.47	—
C1821	1	—
C1822	0.01 B:CHIP	—
C1824	2.2	—
C1826	100p CH:CHIP	—
IC1801	LA7337	—
L1801	6.8μH	—
L1802	22μH	—
L1803	68μH	—
L1804	27μH	—
L1805	JW(5)	—
L1806	47μH	—
Q1801	2SA1162-YG-TE85L	—
Q1802	UN211L-TX	—
Q1804	2SC2712-YG-TE85L	—
Q1805	2SC2712-YG-TE85L	—
Q1806	2SC2712-YG-TE85L	—
Q1807	UN2213-TX	—
Q1808	UN2111-TX	—
R1801	47k :CHIP	—
R1802	8.2k :CHIP	—
R1803	9.1k :CHIP	—
R1804	20k :CHIP	—
R1805	27k :CHIP	—
R1806	8.2k :CHIP	—
R1807	1k :CHIP	—
R1808	39k :CHIP	—
R1809	27k :CHIP	—
R1810	470 :CHIP	—
R1811	5.6k :CHIP	—
R1812	22k :CHIP	—
R1813	15k :CHIP	—
R1814	10k :CHIP	—
R1815	47k :CHIP	—
R1816	2.7k :CHIP	—
R1817	47k :CHIP	—
R1818	47k :CHIP	—
R1819	10k :CHIP	—
R1820	0 :CHIP	—
R1821	27k :CHIP	—
R1822	39k :CHIP	—
R1823	10k :CHIP	—
R1831	0 :CHIP	—

—: Not used

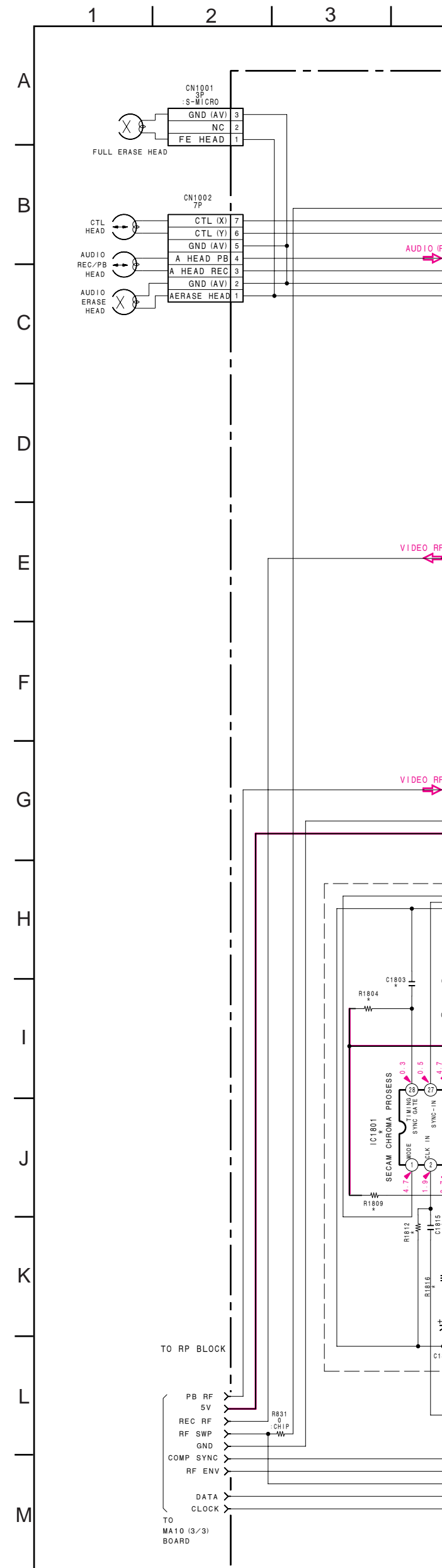

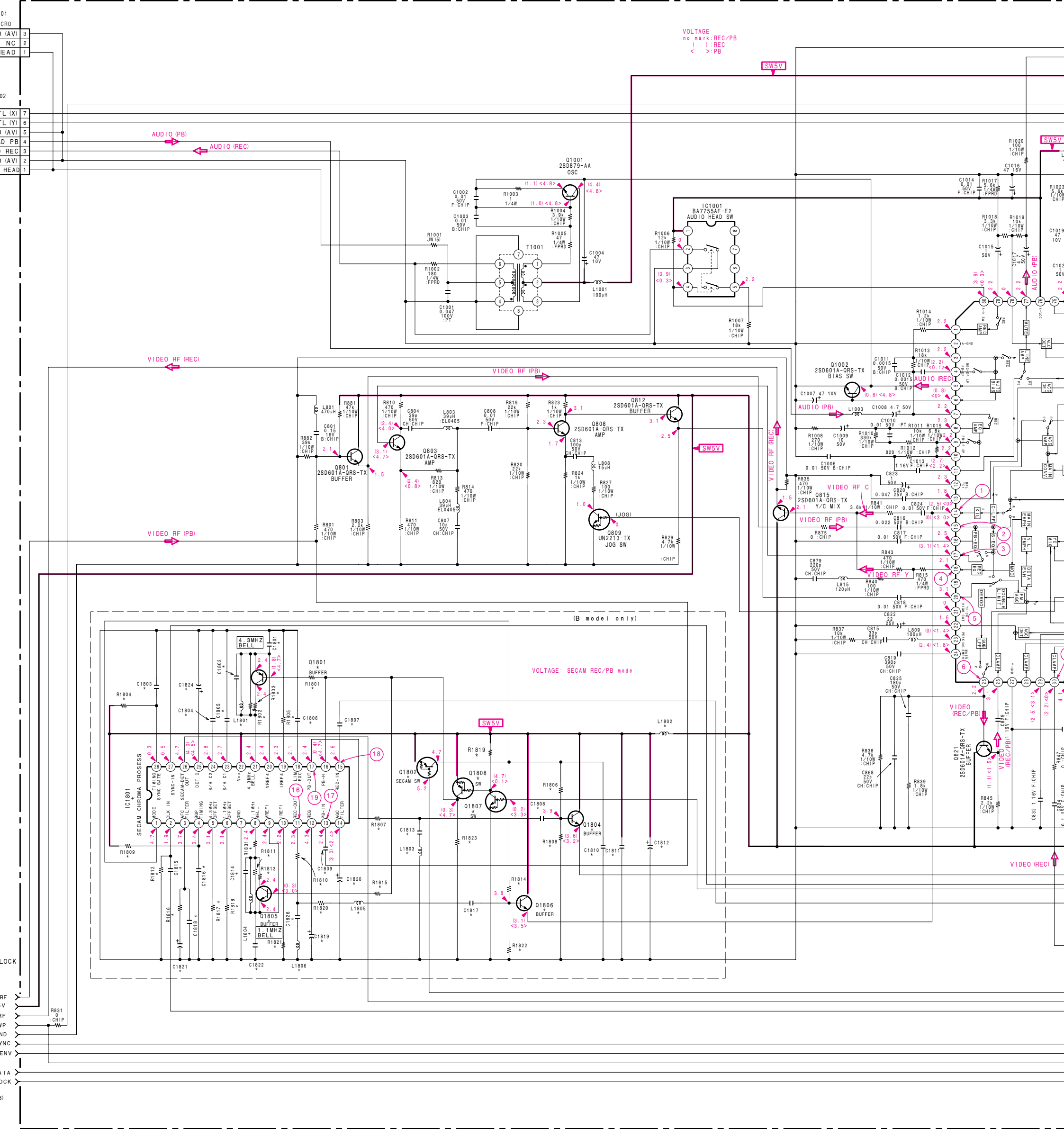

# MA10 (2/3) (Y/C PROCESS, SECAM CHROMA PROCESS)

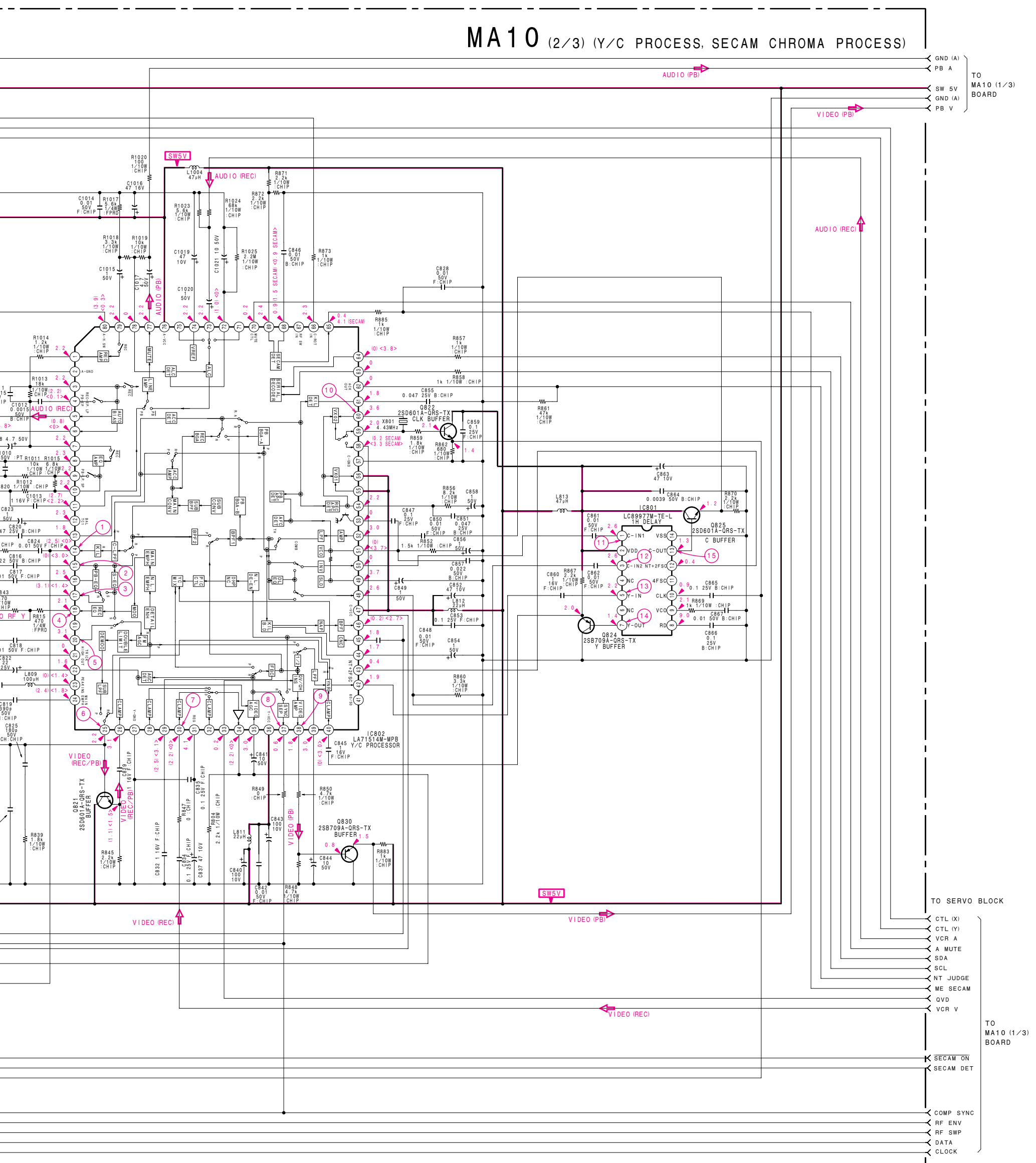

GND (A)  
PB A  
SW 5V  
GND (A)  
PB V

TO  
MA10 (1/3)  
BOARD

TO SERVO BLOCK

CTL (X)  
CTL (Y)  
VCR A  
A MUTE  
SDA  
SCL  
NT JUDGE  
ME SECAM  
QVD  
VCR V

TO  
MA10 (1/3)  
BOARD

SECAM ON  
SECAM DET

COMP SYNC  
RF ENV  
RF SWP  
DATA  
CLOCK

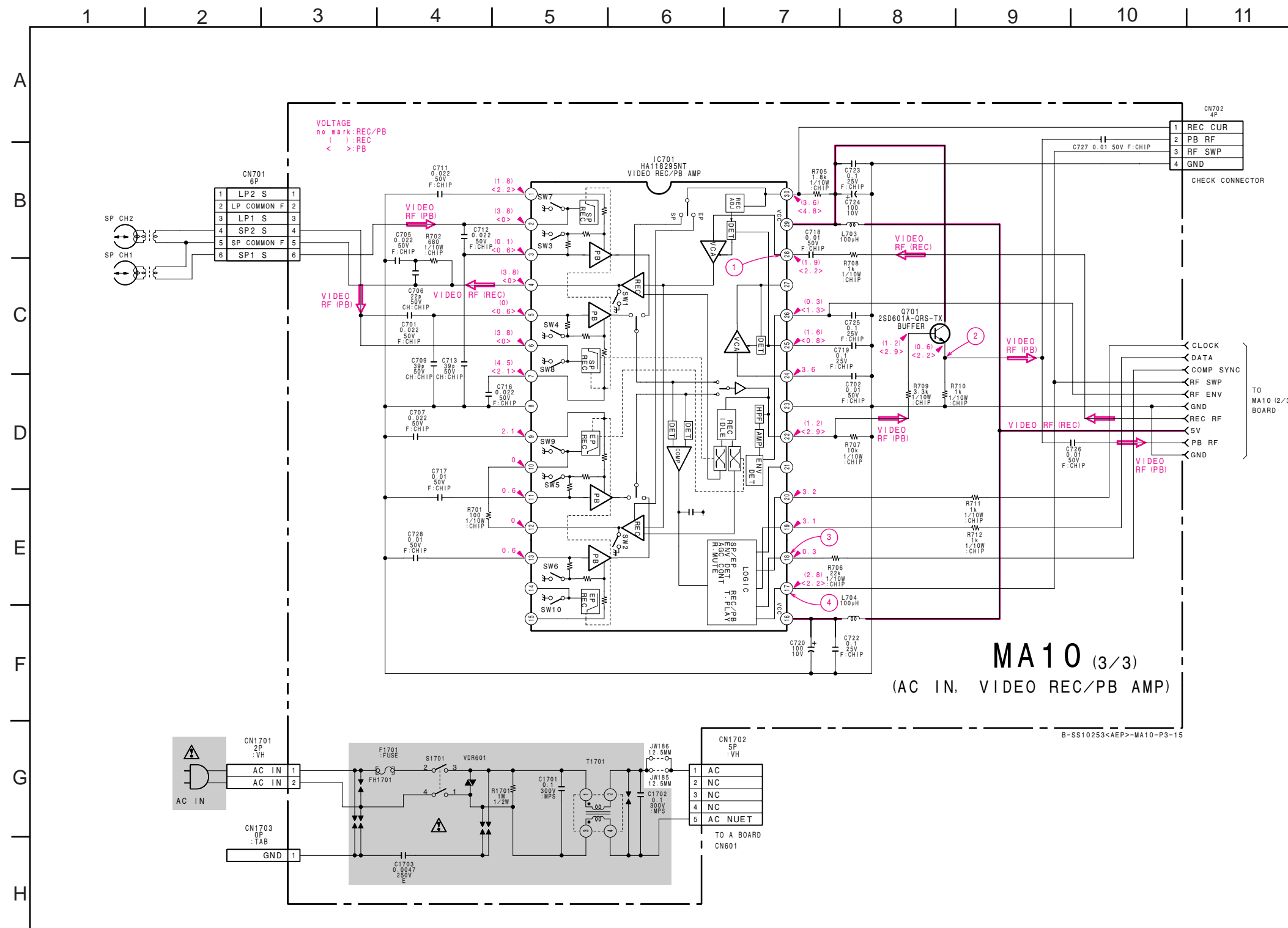

• MA10 (3/3) BOARD WAVEFORMS

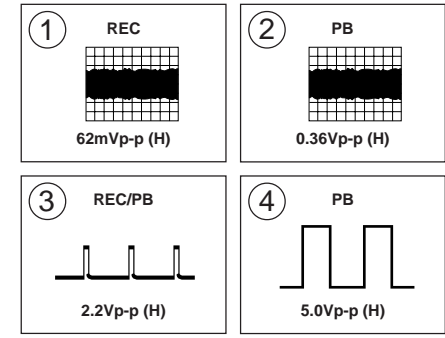

5-4.SEMICONDUCTORS

IC

BA10393F-E2  
BA6305F-E2  
BA7755AF-E2  
M24C16-MN6T  
NJM062M  
S-3510ACFJA-TB

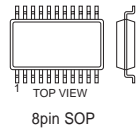

CXA1855Q

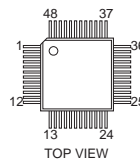

CXA2139S

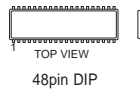

CXP85452-233Q-TL

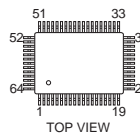

CXP87852-063Q-TL

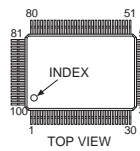

GP3S120

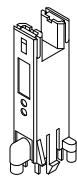

HA118295NT

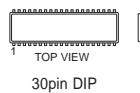

LA6393DLL  
M5216P

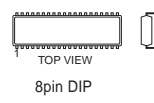

LA71514M-MPB

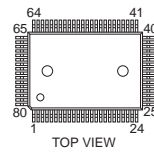

LA7337

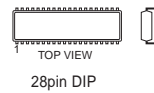

LA7840L

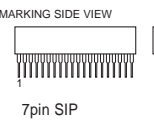

LB1643

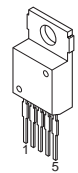

LC89978M-TE-L

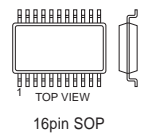

L78L33ABZ-AP



MC33364DR2

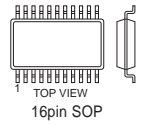

PC123F2

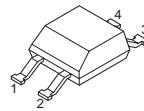

PQ05RD11  
PQ09RD11

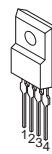

PQ30RV11

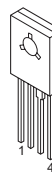

PST572C

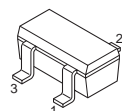

SAA5563PS/M3/0189

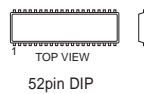

SBX1981-51(21)

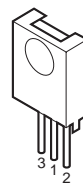

SDA5650-GEG

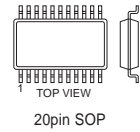

SE-135N-LF4

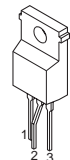

SI-3120C

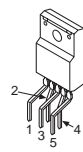

STR-F6654-LF135

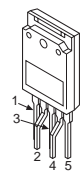

TDA7494

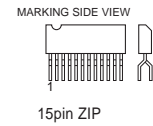

μPC1093J-1-T

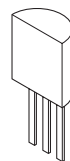

μPC574J

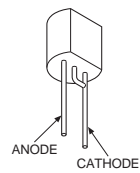

TRANSISTOR

BC327-25  
BC337-25  
2SA1091O  
2SC1815-GR  
2SD879

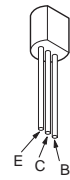

BF420-126

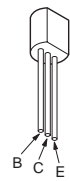

BU4508DX-ON5210  
2SC5388



DTC114TK  
UN211L  
UN2113  
UN2211  
UN2213  
2SA1037AK-T146-R  
2SA1162-G  
2SC1623-L5L6  
2SC2712-YG  
2SD601A-Q

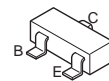

RPT-37PBT32  
RPT-37PB3F

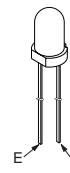

2SA1837  
2SC4793

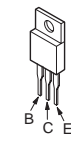

2SA933AS-QT  
2SC2785-HFE

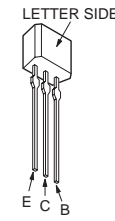

2SK2251-01  
2SK2733(LBS4SONY)

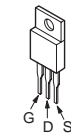

DIODE

AK04V0  
D1NL20U  
D1NL20U-TR2  
D2S6MF  
EGP20G  
EL1Z  
ERA22-08  
ERC06-15S  
GP08D  
RG1C-LFC1  
1SS133T-77

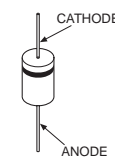

DAN202K

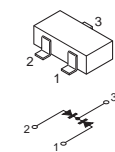

DAP202K

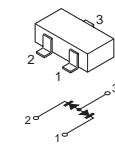

DTZ10B  
DTZ-TT11-16B  
MA111  
1SS355TE-17

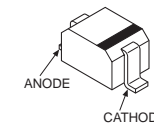

D2SB60F

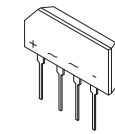

D4SB60L

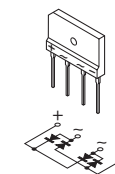

EGP30D

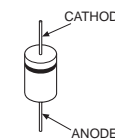

MTZJ-13  
MTZJ-4.3B  
MTZJ-4.7C  
MTZJ-5.1C  
MTZJ-6.2B  
RD10ESB2  
RD18ES-B2  
RD3.9ES-B2  
RD39ES-B2  
RD5.6ESB2  
RD6.2ESB-2  
RD6.8ES-B2  
RD8.2ES-B3  
RD9.1ES-B3  
1SS119-25  
11ES2

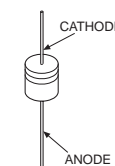

RU4AM-T3

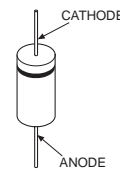

RN1Z-LF-B1  
RN3Z-LF014-302

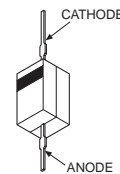

UDZS-TE17-5.6B  
UDZS-TE17-9.1B

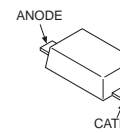

GL528V1

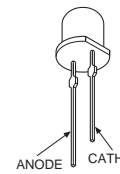

SLR-325DCT31  
SLR-325VCT31

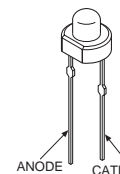



# SECTION 6 EXPLODED VIEWS

The components identified by shading and mark  $\triangle$  are critical for safety. Replace only with part number specified.

Les composants identifiés par la marque  $\triangle$  sont critiques pour la sécurité. Ne les remplacer que par une pièce portant le numéro spécifié.

**NOTE:**

- Items with no part number and no description are not stocked because they are seldom required for routine service.

- The construction parts of an assembled part are indicated with a collation number in the remark column.
- Items marked " \* " are not stocked since they are seldom required for routine service. Some delay should be anticipated when ordering these items.

**6-1. PICTURE TUBE**

- : 7-685-648-79 +BVTP 3X12
- ▲ : 7-685-663-71 +BVTP 4X16
- : 7-685-663-79 +BVTP 4X16

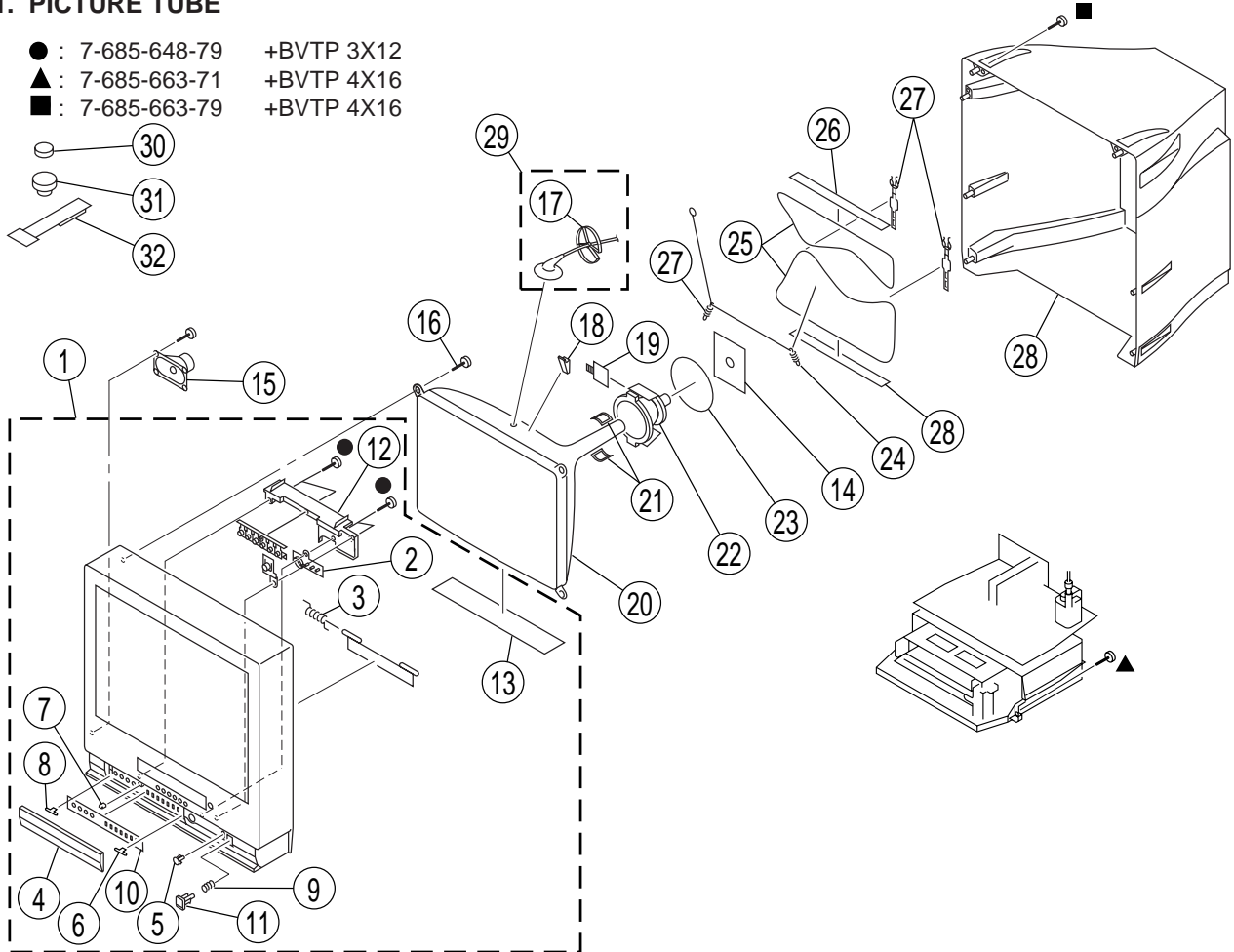

REF. NO.	PART NO.	DESCRIPTION	REMARK
1	X-4200-633-1	BEZNET ASSY (14FV1D, 14FV1E)	2-13
1	X-4200-643-1	BEZNET ASSY (14FV1B)	2-13
1	X-4200-644-1	BEZNET ASSY (14FV1U)	2-13
1	X-4200-628-1	BEZNET ASSY (21FV1D, 21FV1E)	2-13
1	X-4200-638-1	BEZNET ASSY (21FV1U)	2-13
1	X-4200-639-1	BEZNET ASSY (21FV1B)	2-13
2	4-205-325-01	GUIDE, LIGHT	
3	4-050-155-01	SPRING, FL	
4	4-205-318-01	DOOR, CONTROL	
5	4-205-326-01	WINDOW, REMOTE	
6	3-703-035-11	SHAFT, LID	
7	4-072-192-01	CHATCHER, PUSH	
8	4-045-250-01	DAMPER	
9	4-204-426-01	SPRING	
10	4-205-387-01	LABEL CONTROL (AEP/ESP/UK model)	
10	4-205-387-11	LABEL CONTROL (FR model)	
11	4-205-323-01	BUTTON, POWER	
12	4-205-319-01	TRAY, CASSETTE	
13	* 4-203-553-11	SHEET, BLOTTING (21inch model)	
14	* A-1639-006-A	CVM BOARD COMPLETE (14inch model)	
14	* A-1639-005-A	CVM BOARD COMPLETE (21inch model)	
15	1-529-474-11	SPEAKER (5CM) (14inch model)	
15	1-529-710-11	SPEAKER (5X9CM) (21inch model)	
16	4-365-808-01	SCREW (5), TAPPING	
17	4-203-097-01	HOLDER, HV (14inch model)	

REF. NO.	PART NO.	DESCRIPTION	REMARK
18	4-074-601-01	SPACER, DY (14inch model)	
18	4-704-495-01	SPACER, DY (21inch model)	
19	2-163-920-01	PLATE, TLH CORRECTION	
20	$\triangle$ 8-738-570-05	PICTURE TUBE (A34LRG70X) (14inch model)	
20	$\triangle$ 8-738-836-05	PICTURE TUBE (A51LPT60X) (21inch model)	
21	$\triangle$ 1-416-864-12	COIL, VM (14inch model)	
22	$\triangle$ 8-451-401-21	DEFLECTION YOKE (Y14RSA-L) (21inch model)	
22	$\triangle$ 8-451-505-41	DEFLECTION YOKE (Y21RSA-L) (21inch model)	
23	$\triangle$ 1-452-728-61	COIL, NA ROTATION (RT-154) (21inch model)	
24	4-369-318-21	SPRING, TENSION	
25	$\triangle$ 1-419-548-11	COIL, DEGAUSSING (14inch model)	
25	$\triangle$ 1-419-772-11	COIL, DEGAUSSING (21inch model)	
26	4-203-390-11	CUSHION, DGC (21inch model)	
27	4-205-377-01	HOLDER, DGC (14inch model)	
27	4-204-900-01	BAND, DGC (21inch model)	
28	4-205-314-01	REAR COVER (14) (14inch model)	
28	4-205-316-01	REAR COVER (21) (21inch model)	
29	$\triangle$ 1-251-317-32	CAP ASSY, HIGH VOLTAGE 17 (14inch model)	
30	1-452-032-00	MAGNET, DISK ; 10mmø	
31	1-452-094-00	MAGNET, ROTABLE DISK ; 15mmø	
32	4-051-736-21	PIECE A(90), CONV. CORRECT	

## 6-2. CHASSIS

- : 7-685-648-79 +BVTP 3X12  
 △ : 7-682-147-01 +P 3X6

The components identified by shading and mark △ are critical for safety.  
 Replace only with part number specified.

Les composants identifiés par la marque △ sont critiques pour la sécurité.  
 Ne les remplacer que par une pièce portant le numéro spécifié.

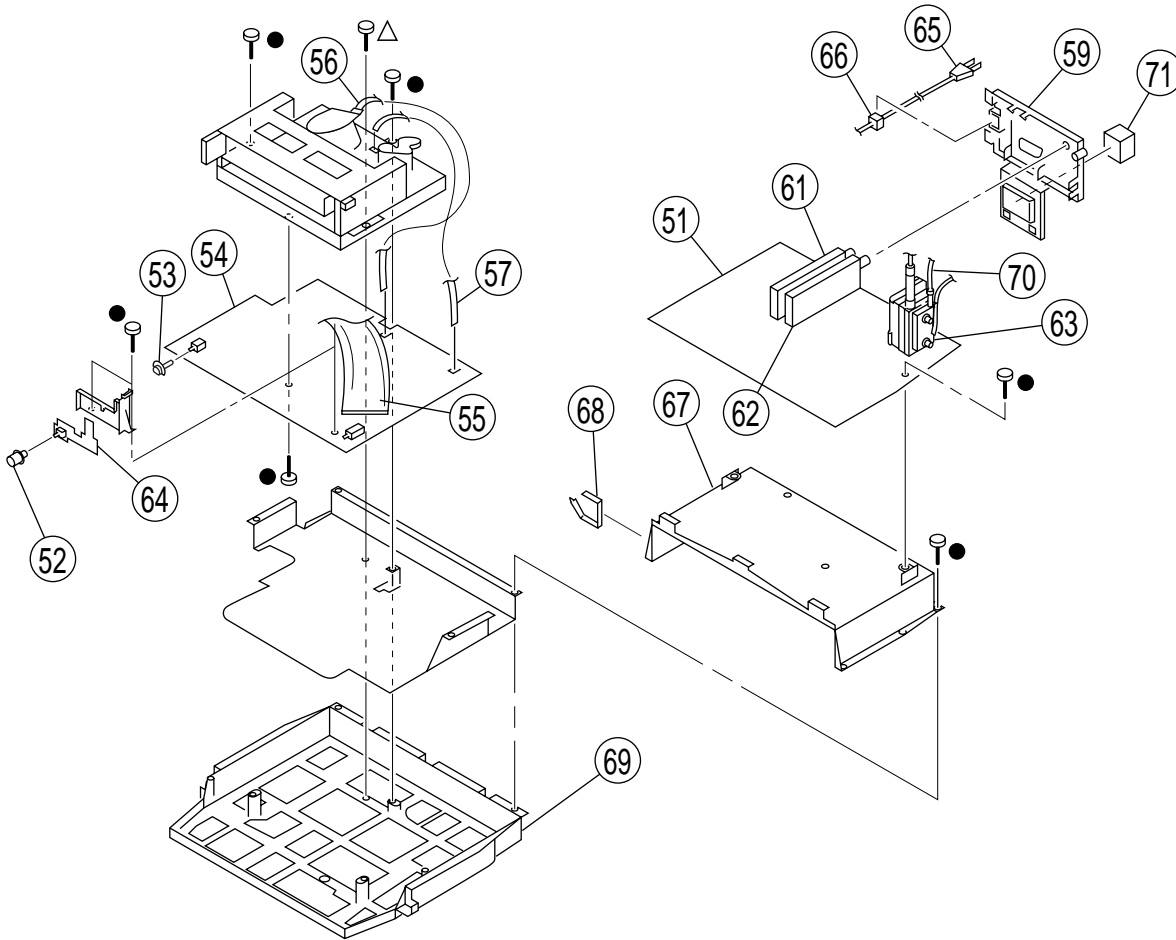

REF. NO.	PART NO.	DESCRIPTION	REMARK	REF. NO.	PART NO.	DESCRIPTION	REMARK
51	* A-1632-904-A	A BOARD, COMPLETE	(14FV1D,14FV1E)	60	3-979-508-01	SCREW +HXA TPSW 3X8	
51	* A-1632-910-A	A BOARD, COMPLETE	(14FV1B)	61	8-598-536-00	FRONTED BTF-EF412 (VTR)	(FR model)
51	* A-1632-911-A	A BOARD, COMPLETE	(14FV1U)	61	8-598-532-00	FRONTED BTF-EC402 (VTR)	(AEP/ESP model)
51	* A-1632-900-A	A BOARD, COMPLETE	(21FV1D,21FV1E)	61	8-598-528-00	FRONTED BTF-EU602 (VTR)	(UK model)
51	* A-1632-907-A	A BOARD, COMPLETE	(21FV1B)	62	8-598-536-00	FRONTED BTF-EF412 (TV)	(FR model)
51	* A-1632-906-A	A BOARD, COMPLETE	(21FV1U)	62	8-598-532-00	FRONTED BTF-EC402 (TV)	(AEP/ESP model)
52	4-205-324-01	BUTTON, RECORDING		62	8-598-528-00	FRONTED BTF-EU602 (TV)	(UK model)
53	4-205-332-01	BUTTON, MAIN POWER		63	△ 8-598-852-00	TRANSFORMER ASSY, FLYBACK (NX-1912/M)	(14inch model)
54	* A-1635-042-A	MA10 BOARD, COMPLETE	(14FV1D,14FV1U)	63	△ 1-453-314-11	TRANSFORMER ASSY, FLYBACK	(21inch model)
54	* A-1635-043-A	MA10 BOARD, COMPLETE	(14FV1E)	64	* A-1646-216-A	H10 BOARD, COMPLETE	
54	* A-1635-044-A	MA10 BOARD, COMPLETE	(14FV1B)	65	△ 1-765-286-11	CORD, POWER	(AEP,ESP,FR model)
54	* A-1635-042-A	MA10 BOARD, COMPLETE	(21FV1D,21FV1U)	65	△ 1-776-860-12	POWER CORD, FILTER (UK)	(UK model)
54	* A-1635-043-A	MA10 BOARD, COMPLETE	(21FV1E)	66	4-022-115-00	HOLDER, AC CORD	
54	* A-1635-044-A	MA10 BOARD, COMPLETE	(21FV1B)	67	* 4-205-333-01	COVER, TOP	
55	1-900-905-61	CONNECTOR ASSY 35P		68	* 4-316-015-00	HOLDER, WIRE	
56	1-900-905-74	CONNECTOR ASSY, MICRO 5P	(21inch model)	69	* 4-205-327-01	BRACKET, MAIN	
57	1-900-905-56	CONNECTOR ASSY 7P		70	△ 1-900-900-24	LEAD ASSY, FOCUS	
58	1-900-905-60	CONNECTOR ASSY 5P		71	1-419-494-44	COIL, CHOKE 56.0MM	(21inch model)
59	4-205-331-01	BOARD TERMINAL					

### 6-3. MECHANISM DECK ASSEMBLY (1)

▲ : 7-685-646-79 +BVTP 3X8

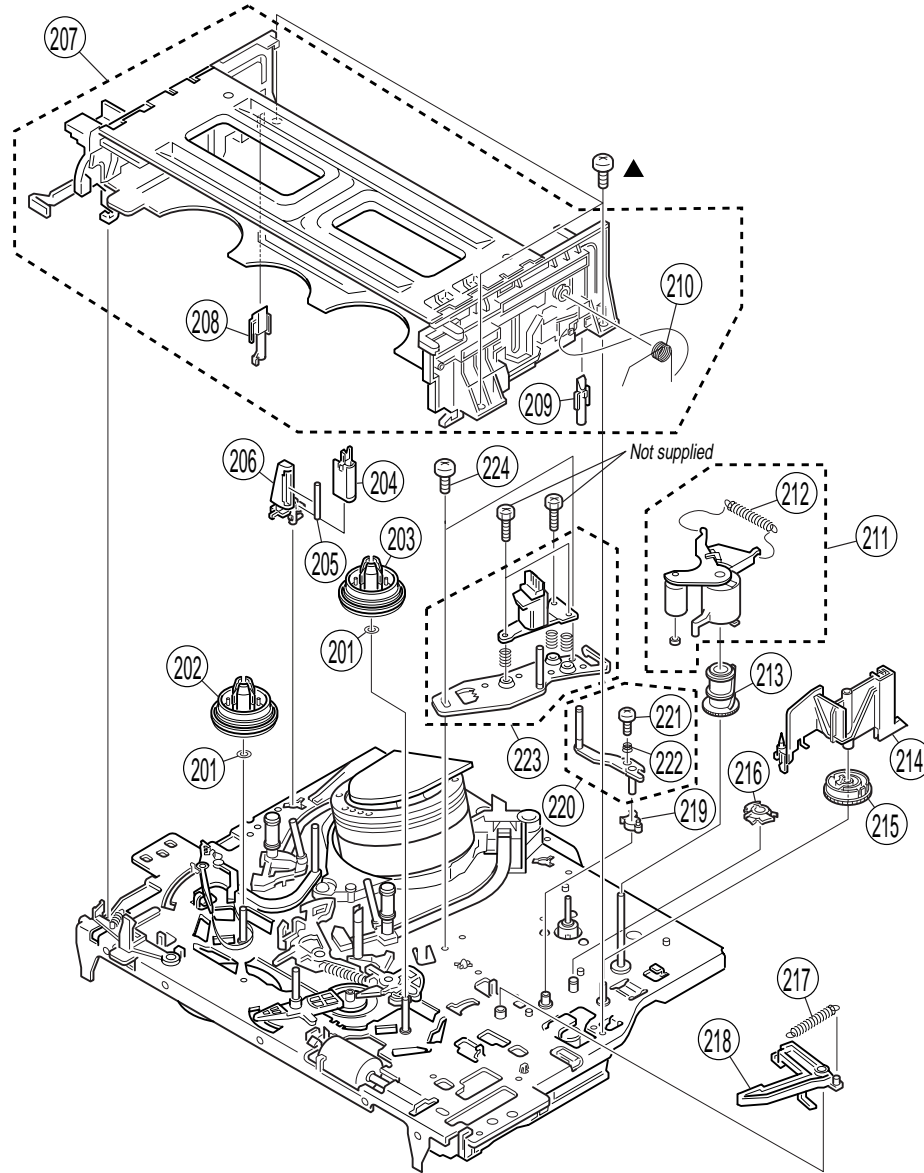

REF. NO.	PART NO.	DESCRIPTION	REMARK	REF. NO.	PART NO.	DESCRIPTION	REMARK
201	3-977-509-01	WASHER, THRUST		213	3-977-447-01	GEAR, ELEVATOR	
202	3-977-507-01	TABLE, REEL (S)		214	3-977-514-01	OPENER, LID	
203	3-977-508-01	TABLE, REEL (T)		215	3-977-441-03	GEAR, PINCH PRESSING	
204	1-500-471-11	HEAD, FE		216	3-977-445-02	GEAR, TG8 ARM DRIVING	
205	3-977-495-01	SHAFT TG2		217	3-062-763-01	SPRING, EXTENSION (RVS BRAKE)	
206	3-977-494-01	HOLDER, FEH		218	X-3947-582-1	ARM ASSY, RVS BRAKE	
207	A-6759-619-B	FL COMPLETE ASSY	208-210	219	3-977-446-01	GEAR, TG8 ARM	
208	3-977-535-01	PLATE, LUMINOUS (END SENSOR)		220	X-3947-590-1	TG8 ASSY	221, 222
209	3-977-536-01	PLATE, LUMINOUS (TOP SENSOR)		221	3-059-300-03	LOCK ACE SCREW	
210	3-970-471-01	SPRING (DECK OPEN), TORSION		222	3-059-958-01	SPRING, TG8	
211	A-6759-863-B	PRESS BLOCK ASSY, PINCH	212	223	A-6775-791-A	ACE BLOCK ASSY (ALPS) (EURO3)	
212	3-958-455-01	SPRING (PINCH), TENSION		224	3-979-508-01	SCREW +HEXA TP SW 3X8	

## 6-4. MECHANISM DECK ASSEMBLY (2)

▲ : 7-685-646-79 +BVTP 3X8

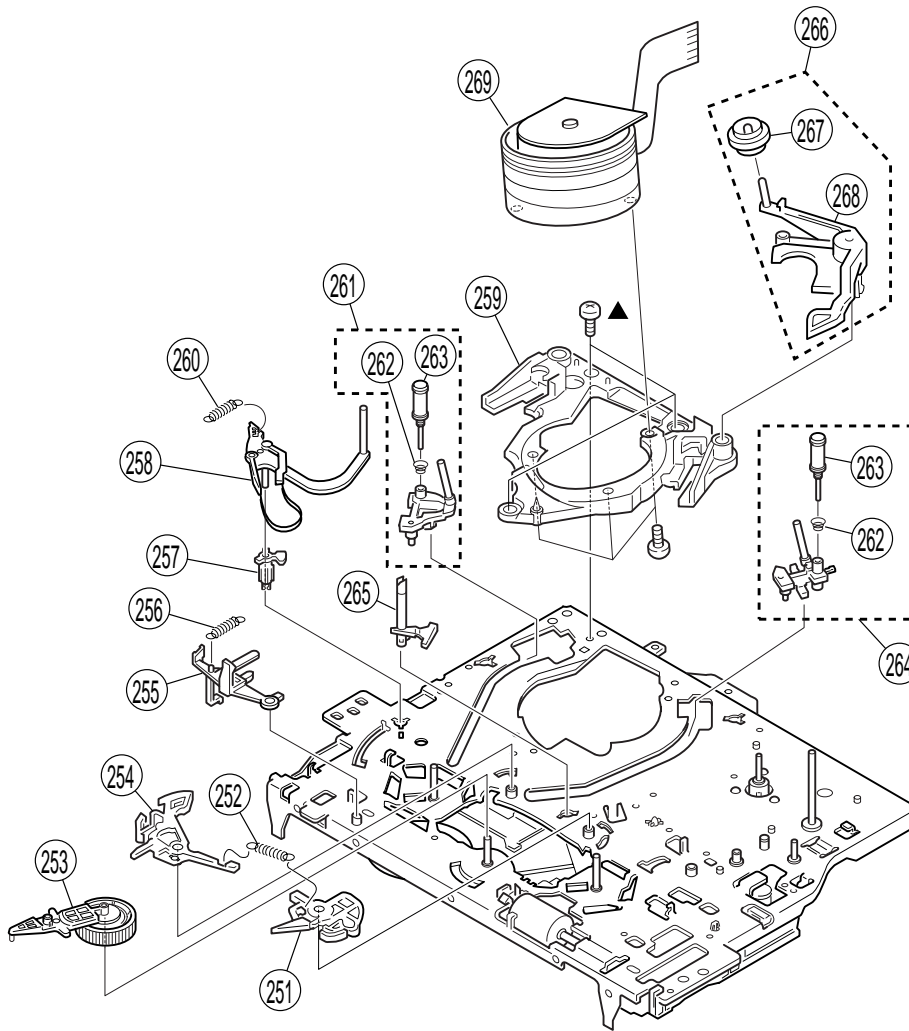

REF. NO.	PART NO.	DESCRIPTION	REMARK	REF. NO.	PART NO.	DESCRIPTION	REMARK
251	X-3947-581-4	BRAKE ASSY, MAIN(T)		261	A-6775-922-A	SHUTTLE (S) BLOCK ASSY, ST	262,263
252	3-977-462-01	SPRING, EXTENTION. (MAIN BRAKE)		262	3-965-178-01	SPRING	
253	X-3947-573-1	ARM ASSY, PENDULUM		263	X-3948-050-1	ROLLER ASSY, GUIDE	
254	X-3947-580-5	BRAKE ASSY, MAIN(S)		264	A-6750-328-G	SHUTTLE (T) BLOCK ASSY	262,263
255	3-050-810-04	LEVER, REC. PROOF		265	3-977-501-01	PLATE, LUMINOUS	
256	3-976-767-01	SPRING, TENS. (REC. PROOF)		266	A-6746-074-G	ROLLER BLOCK ASSY, HC	267,268
257	3-977-487-01	BOSS, TG1 FULCRUM		267	X-3947-255-1	ROLLER ASSY, HC	
258	X-3950-427-1	TG1 ASSY (SD)		268	3-975-724-07	ARM, HC	
259	3-969-632-04	BASE, DRUM		269	x-xxx-xxx-xx	DRUM ASSY (XXX)	
260	3-977-488-01	SPRING (POWER TENSION)					

## 6-5. MECHANISM DECK ASSEMBLY (3)

▲ : 7-685-646-79 +BVTP 3X8  
 □ : 7-685-133-19 +BVTP 2.6

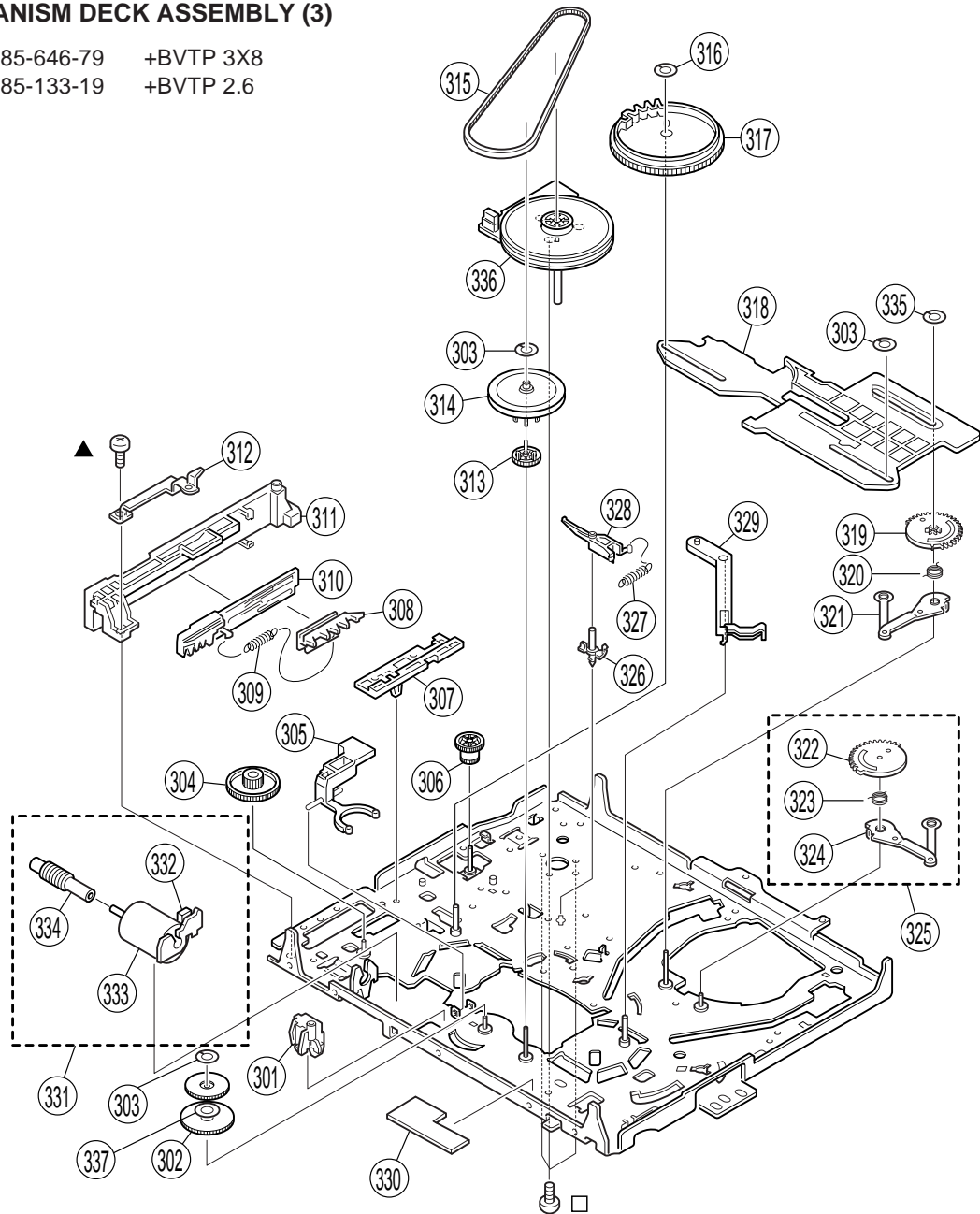

REF. NO.	PART NO.	DESCRIPTION	REMARK	REF. NO.	PART NO.	DESCRIPTION	REMARK
301	3-977-437-01	RETAINER, CAM MOTOR		320	3-977-456-03	SPRING, TORSION (LOAD T)	
302	X-3947-584-1	ASSY, REEL DIRECT		321	X-3948-132-2	LEVER ASSY, LOADING(T)	
303	3-977-443-01	WASHER, STOPPER		322	3-977-451-01	GEAR, LOADING(S)	
304	3-977-438-01	WORM - WHEEL		323	3-977-452-01	SPRING, TORSION (LOAD S)	
305	3-977-506-01	ARM, LIMITTER SELECTION		324	X-3948-133-1	LEVER ASSY, LOADING(S)	
306	3-977-444-01	GEAR, PINCH TRANSMISSION		325	A-6759-616-A	GEAR BLOCK ASSY, LOADING(S)322-324	
307	3-977-515-01	GUIDE, FL SLIDER		326	3-977-468-01	SHAFT, CAPSTAN BRAKE	
308	3-977-517-01	PLATE, SLIDE, FL		327	3-977-467-02	SPRING, CAP BRAKE	
309	3-977-519-01	SPRING, TENS. (LIMIT, FL)		328	X-3947-583-1	BRAKE ASSY, CAPSTAN	
310	3-977-518-02	PLATE, LIMITTER, FL		329	3-977-489-01	ARM, TG1 DRIVING	
311	3-977-516-01	HOLDER, FL SLIDER		330	3-989-917-01	SPACER (REC PROOF)	
312	3-977-877-01	PLATE, RETAINER		331	X-3947-577-1	MOTOR ASSY, CAM (LOADING)	332-334
313	3-977-504-01	GEAR, CLUTCH		332	1-766-723-21	CONNECTOR, BOARD TO BOAR 3P	
314	X-3947-585-1	GEAR ASSY, PULLEY		333	1-541-309-11	MOTOR, L (RF-370C)	
315	3-977-510-01	BELT, RUBBER		334	3-977-436-01	WORM	
316	3-056-952-11	WASHER, STOPPER		335	3-056-824-01	WASHER, STOPPER	
317	3-977-439-01	GEAR, CAM		336	1-698-971-11	MOTOR, DC	
318	3-977-442-01	SLIDER		337	3-974-477-01	WASHER, (GEAR, LIMITTER)	
319	3-977-455-01	GEAR, LOADING(T)					

## SECTION 7

# ELECTRICAL PARTS LIST

A

**NOTE:**

The components identified by shading and mark  $\triangle$  are critical for safety. Replace only with part number specified.

Les composants identifiés par la marque  $\triangle$  sont critiques pour la sécurité. Ne les remplacer que par une pièce portant le numéro spécifié.

• Items marked " \* " are not stocked since they are seldom required for routine service. Some delay should be anticipated when ordering these items.

• All variable and adjustable resistors have characteristic curve B, unless otherwise noted.

**RESISTORS**

• All resistors are in ohms  
• F : nonflammable

When indicating parts by reference number, please include the board name.

• CAPACITORS  
PF :  $\mu\mu$  F

• There are some cases the reference number on one board overlaps on the other board. Therefore, when ordering parts by the reference number, please include the board name.

## TV BLOCK

REF. NO.	PART NO.	DESCRIPTION	REMARK	REF. NO.	PART NO.	DESCRIPTION	REMARK
	* A-1632-910-AA BOARD, COMPLETE (KV-14FV1B)	*****		C308	1-107-823-11	CERAMIC CHIP 0.47UF	10.00% 16V (21inch model)
	* A-1632-904-AA BOARD, COMPLETE (KV-14FV1D/14FV1E)	*****		C309	1-126-965-11	ELECT 22UF	20.00% 50V
				C310	1-126-964-11	ELECT 10UF	20.00% 50V
				C311	1-104-664-11	ELECT 47UF	20.00% 25V
	* A-1632-911-AA BOARD, COMPLETE (KV-14FV1U)	*****		C312	1-126-963-11	ELECT 4.7UF	20.00% 50V
				C313	1-115-339-11	CERAMIC CHIP 0.1UF	10.00% 50V
				C315	1-104-664-11	ELECT 47UF	20.00% 25V
	* A-1632-907-AA BOARD, COMPLETE (KV-21FV1B)	*****		C317	1-126-964-11	ELECT 10UF	20.00% 50V
				C318	1-104-665-11	ELECT 100UF	20.00% 25V
	* A-1632-900-AA BOARD, COMPLETE (KV-21FV1D/21FV1E)	*****		C319	1-163-038-11	CERAMIC CHIP 0.1UF	25V
				C320	1-163-031-11	CERAMIC CHIP 0.01UF	50V
				C321	1-163-038-11	CERAMIC CHIP 0.1UF	25V
				C322	1-163-031-11	CERAMIC CHIP 0.01UF	50V
	* A-1632-906-AA BOARD, COMPLETE (KV-21FV1U)	*****		C323	1-163-031-11	CERAMIC CHIP 0.01UF	50V
	1-555-110-00 CABLE, PIN (TU101-CP101)			C325	1-104-664-11	ELECT 47UF	20.00% 25V
	4-382-854-01 SCREW (M3X8), P, SW (+)			C326	1-126-960-11	ELECT 1UF	20.00% 50V
	(IC501, IC603, IC605, IC608, IC610, Q802)			C327	1-163-009-11	CERAMIC CHIP 0.001UF	10.00% 50V
	4-382-854-11 SCREW (M3X10), P, SW (+) (IC606)			C328	1-107-714-11	ELECT 10UF	20.00% 16V
				C329	1-163-113-00	CERAMIC CHIP 68PF	5.00% 50V
	<CAPACITOR>			C330	1-104-665-11	ELECT 100UF	20.00% 25V
C101	1-163-021-91	CERAMIC CHIP 0.01UF	10.00% 50V	C333	1-163-021-91	CERAMIC CHIP 0.01UF	10.00% 50V
C102	1-126-964-11	ELECT 10UF	20.00% 50V	C335	1-163-021-91	CERAMIC CHIP 0.01UF	10.00% 50V
C103	1-163-021-91	CERAMIC CHIP 0.01UF	10.00% 50V	C339	1-163-038-11	CERAMIC CHIP 0.1UF	25V
C104	1-104-664-11	ELECT 47UF	20.00% 25V	C401	1-126-964-11	ELECT 10UF	20.00% 50V
C105	1-164-004-11	CERAMIC CHIP 0.1UF	10.00% 25V	C402	1-126-964-11	ELECT 10UF	20.00% 50V
C106	1-104-664-11	ELECT 47UF	20.00% 25V	C403	1-126-964-11	ELECT 10UF	20.00% 50V
C107	1-163-021-91	CERAMIC CHIP 0.01UF	10.00% 50V	C404	1-126-964-11	ELECT 10UF	20.00% 50V
C108	1-126-964-11	ELECT 10UF	20.00% 50V	C405	1-104-664-11	ELECT 47UF	20.00% 25V
C109	1-163-021-91	CERAMIC CHIP 0.01UF	10.00% 50V	C406	1-164-346-11	CERAMIC CHIP 1UF	16V
C110	1-104-664-11	ELECT 47UF	20.00% 25V	C407	1-164-346-11	CERAMIC CHIP 1UF	16V
C111	1-164-004-11	CERAMIC CHIP 0.1UF	10.00% 25V	C408	1-163-009-11	CERAMIC CHIP 0.001UF	10.00% 50V
C112	1-104-664-11	ELECT 47UF	20.00% 25V	C410	1-104-664-11	ELECT 47UF	20.00% 25V
C113	1-163-113-00	CERAMIC CHIP 68PF	5.00% 50V	C412	1-164-505-11	CERAMIC CHIP 2.2UF	16V
C114	1-163-113-00	CERAMIC CHIP 68PF	5.00% 50V	C413	1-126-935-11	ELECT 470UF	20.00% 6.3V
C115	1-163-113-00	CERAMIC CHIP 68PF	5.00% 50V	C414	1-164-346-11	CERAMIC CHIP 1UF	16V
C116	1-164-346-11	CERAMIC CHIP 1UF	16V	C418	1-164-346-11	CERAMIC CHIP 1UF	16V
C117	1-164-346-11	CERAMIC CHIP 1UF	16V	C419	1-163-021-91	CERAMIC CHIP 0.01UF	10.00% 50V
C118	1-164-004-11	CERAMIC CHIP 0.1UF	10.00% 25V	C420	1-163-021-91	CERAMIC CHIP 0.01UF	10.00% 50V
C119	1-164-004-11	CERAMIC CHIP 0.1UF	10.00% 25V	C421	1-163-021-91	CERAMIC CHIP 0.01UF	10.00% 50V
C120	1-163-809-11	CERAMIC CHIP 0.047UF	10.00% 25V	C501	1-126-934-11	ELECT 220UF	20.00% 16V
C121	1-104-760-11	CERAMIC CHIP 0.047UF	10.00% 50V	C502	1-126-960-11	ELECT 1UF	20.00% 50V
C122	1-163-253-11	CERAMIC CHIP 120PF	5.00% 50V	C504	1-107-910-11	ELECT 100UF	20.00% 50V
C123	1-163-253-11	CERAMIC CHIP 120PF	5.00% 50V	C505	1-115-339-11	CERAMIC CHIP 0.1UF	10.00% 50V
C124	1-163-113-00	CERAMIC CHIP 68PF	5.00% 50V	C507	1-107-910-11	ELECT 100UF	20.00% 50V
C301	1-126-963-11	ELECT 4.7UF	20.00% 50V	C508	1-106-220-00	MYLAR 0.1UF	10.00% 100V
C302	1-163-233-11	CERAMIC CHIP 18PF	5.00% 50V	C509	1-137-194-81	FILM 0.47UF	5.00% 50V
C303	1-126-964-11	ELECT 10UF	20.00% 50V (21inch model)	C510	1-163-031-11	CERAMIC CHIP 0.01UF	50V
C304	1-163-233-11	CERAMIC CHIP 18PF	5.00% 50V	C511	1-102-244-00	CERAMIC 220PF	10.00% 500V
C306	1-163-259-91	CERAMIC CHIP 220PF	5.00% 50V	C513	1-126-941-11	ELECT 470UF	20.00% 25V
C307	1-126-957-11	ELECT 0.22UF	20.00% 50V	C514	1-163-031-11	CERAMIC CHIP 0.01UF	50V
C308	1-115-185-11	CERAMIC CHIP 0.033UF	10.00% 50V (14inch model)	C515	1-107-652-11	ELECT 10UF	20.00% 250V
				C601	1-104-664-11	ELECT 47UF	20.00% 25V
				C602	$\triangle$ 1-117-699-51	CERAMIC 0.001UF	250V
				C603	$\triangle$ 1-117-699-51	CERAMIC 0.001UF	250V

The components identified by shading and mark  $\Delta$  are critical for safety. Replace only with part number specified.

Les composants identifiés par la marque  $\Delta$  sont critiques pour la sécurité. Ne les remplacer que par une pièce portant le numéro spécifié.



REF. NO.	PART NO.	DESCRIPTION	REMARK	REF. NO.	PART NO.	DESCRIPTION	REMARK
C604	$\Delta$ 1-117-699-51	CERAMIC	0.001UF 250V	C808	1-163-275-11	CERAMIC CHIP	0.001UF 5.00% 50V
C605	1-125-991-11	ELECT	180UF 20% 450V	C809	1-163-038-11	CERAMIC CHIP	0.1UF 25V
C606	1-136-165-00	FILM	0.1UF 5.00% 50V	C810	1-162-318-11	CERAMIC	0.001UF 10.00% 500V
C607	$\Delta$ 1-117-699-51	CERAMIC	0.001UF 250V	C812	1-107-366-11	MYLAR	0.022UF 10.00% 200V
C609	1-107-929-11	ELECT	10UF 20.00% 100V				(14inch model)
C610	1-104-664-11	ELECT	47UF 20.00% 25V	C812	1-136-196-11	MYLAR	0.033UF 10.00% 250V
C612	1-126-943-11	ELECT	2200UF 20.00% 25V				(21inch model)
C614	1-130-785-11	MYLAR	0.47UF 10.00% 100V	C813	1-117-721-11	CERAMIC CHIP	4700PF 5.00% 25V
C615	1-130-785-11	MYLAR	0.47UF 10.00% 100V				(14inch model)
C616	1-107-681-41	ELECT	33UF 20.00% 450V	C813	1-164-690-91	CERAMIC CHIP	0.0022UF 5.00% 50V
C617	1-104-664-11	ELECT	47UF 20.00% 25V				(21inch model)
C618	1-163-005-11	CERAMIC CHIP	470PF 10.00% 50V	C817	1-102-114-00	CERAMIC	470PF 10.00% 50V
C619	1-164-645-11	CERAMIC	1000PF 10.00% 500V				(14inch model)
C620	1-126-941-11	ELECT	470UF 20.00% 25V	C818	1-163-263-11	CERAMIC CHIP	330PF 5.00% 50V
C621	1-104-664-11	ELECT	47UF 20.00% 25V				(14inch model)
C622	1-104-664-11	ELECT	47UF 20.00% 25V	C818	1-163-021-91	CERAMIC CHIP	0.01UF 10.00% 50V
C623	1-126-969-11	ELECT	220UF 20.00% 50V				(21inch model)
C624	1-164-645-11	CERAMIC	1000PF 10.00% 500V	C819	1-115-522-11	FILM	1UF 5.00% 250V
C625	1-126-972-11	ELECT	1000UF 20.00% 50V	C820	1-106-375-12	MYLAR	0.022UF 99% 200V
C626	1-126-944-21	ELECT	3300UF 20.00% 25V				(14inch model)
C627	1-164-645-11	CERAMIC	1000PF 10.00% 500V	C820	1-106-383-00	MYLAR	0.047UF 10.00% 200V
C628	1-163-009-11	CERAMIC CHIP	0.001UF 10.00% 50V				(21inch model)
C630	1-162-134-11	CERAMIC	470PF 10.00% 2KV	C821	$\Delta$ 1-162-116-51	CERAMIC	680PF 10.00% 2KV
C631	1-163-021-91	CERAMIC CHIP	0.01UF 10.00% 50V				(14inch model)
C632	1-127-759-51	ELECT	100UF 20% 160V	C821	$\Delta$ 1-162-134-51	CERAMIC	470PF 10.00% 2KV
C633	1-163-021-91	CERAMIC CHIP	0.01UF 10.00% 50V				(21inch model)
C635	1-102-050-00	CERAMIC	0.01UF 500V	C822	1-136-207-11	MYLAR	0.047UF 10.00% 250V
C636	1-163-005-11	CERAMIC CHIP	470PF 10.00% 50V	C823	1-162-131-11	CERAMIC	220PF 10.00% 2KV
C638	1-109-880-11	FILM	0.0015UF 3.00% 2KV	C824	$\Delta$ 1-117-637-31	FILM	5600PF 3.00% 1.2KV
C639	1-163-017-00	CERAMIC CHIP	0.0047UF 10.00% 50V				(14inch model)
C640	1-163-001-11	CERAMIC CHIP	220PF 10.00% 50V	C824	$\Delta$ 1-117-643-21	FILM	9100PF 3.00% 1.2KV
C641	1-102-114-00	CERAMIC	470PF 10.00% 50V				(21inch model)
C642	1-130-338-91	FILM	0.01UF 5.00% 630V	C826	1-137-417-11	MYLAR	0.0047UF 10.00% 200V
C643	1-117-699-11	CERAMIC	0.001UF 250V				
C644	1-163-005-11	CERAMIC CHIP	470PF 10.00% 50V	C827	$\Delta$ 1-129-716-51	FILM	0.015UF 5.00% 630V
C645	1-104-664-11	ELECT	47UF 20.00% 25V				(14inch model)
C646	1-126-943-11	ELECT	2200UF 20.00% 25V	C827	$\Delta$ 1-135-840-51	FILM	0.036UF 3% 400V
C647	1-104-665-11	ELECT	100UF 20.00% 25V				(21inch model)
C648	1-164-004-11	CERAMIC CHIP	0.1UF 10.00% 25V	C830	1-102-030-00	CERAMIC	330PF 10.00% 500V
C649	$\Delta$ 1-117-699-51	CERAMIC	0.001UF 250V				
C650	1-137-605-11	MYLAR	0.01UF 10.00% 250V	<CONNECTOR>			
C655	1-126-942-61	ELECT	1000UF 20.00% 25V	CN301	1-785-386-11	SOCKET, CONNECTOR	35P
C657	1-104-664-11	ELECT	47UF 20.00% 25V	CN302	* 1-564-510-11	PLUG, CONNECTOR	7P
C659	1-161-964-51	CERAMIC	0.0047UF 250V	CN304	* 1-564-508-11	PLUG, CONNECTOR	5P
C660	1-104-666-11	ELECT	220UF 20.00% 25V	CN305	* 1-564-509-11	PLUG, CONNECTOR	6P
C661	1-115-339-11	CERAMIC CHIP	0.1UF 10.00% 50V	CN306	* 1-564-509-11	PLUG, CONNECTOR	6P
C662	1-128-551-11	ELECT	22UF 20.00% 25V	CN601	* 1-691-291-11	PIN, CONNECTOR (PC BOARD)	5P
C663	1-104-665-11	ELECT	100UF 20.00% 25V	CN602	* 1-508-786-00	PIN, CONNECTOR (5mm PITCH)	2P
C664	1-104-665-11	ELECT	100UF 20.00% 25V	CN603	* 1-508-765-00	PIN, CONNECTOR (5mm PITCH)	3P
C665	1-104-665-11	ELECT	100UF 20.00% 25V	CN604	1-695-915-11	TAB (CONTACT)	
C666	1-126-933-11	ELECT	100UF 20.00% 16V	CN606	* 1-691-960-11	PIN, CONNECTOR (PC BOARD)	3P
C667	1-102-106-00	CERAMIC	100PF 10.00% 50V				(21inch model)
C668	1-126-949-11	ELECT	220UF 20.00% 35V	CN801	* 1-580-798-11	CONNECTOR PIN (DY)	6P
C669	1-104-664-11	ELECT	47UF 20.00% 25V	CN803	* 1-564-508-11	PLUG, CONNECTOR	5P
C670	1-104-664-11	ELECT	47UF 20.00% 25V	<COMPOSITION CIRCUIT BLOCK>			
C801	1-106-371-00	MYLAR	0.015UF 99% 200V	CP101	1-251-658-11	SPLITTER RF	
			(14inch model)				
C801	1-107-364-11	MYLAR	0.01UF 10.00% 400V	<DIODE>			
			(21inch model)	D101	8-719-914-43	DIODE DAN202K	
C802	1-126-941-11	ELECT	470UF 20.00% 25V	D102	8-719-069-55	ZENER DIODE UDZS-TE17-5.6B	
C803	1-119-859-11	FILM	0.36UF 5.00% 250V	D103	8-719-069-55	ZENER DIODE UDZS-TE17-5.6B	
			(14inch model)	D301	8-719-109-89	ZENER DIODE RD5.6ESB2	
C803	1-117-667-11	FILM	0.47UF 5.00% 250V	D302	8-719-109-89	ZENER DIODE RD5.6ESB2	
			(21inch model)	D304	8-719-110-14	ZENER DIODE RD9.1ES-B3	
C804	1-104-664-11	ELECT	47UF 20.00% 25V	D305	8-719-911-19	DIODE 1SS119-25	
C805	1-123-024-21	ELECT	33UF 160V	D307	8-719-911-19	DIODE 1SS119-25	
C806	1-162-117-00	CERAMIC	100PF 10.00% 500V	D308	8-719-110-14	ZENER DIODE RD9.1ES-B3	
			(14inch model)	D313	8-719-110-14	ZENER DIODE RD9.1ES-B3	
C806	1-102-228-00	CERAMIC	470PF 10.00% 500V				
			(21inch model)	D314	8-719-914-44	DIODE DAP202	(21inch model)
C807	1-107-650-11	ELECT	3.3UF 20.00% 250V				



The components identified by shading and mark  $\Delta$  are critical for safety. Replace only with part number specified.

Les composants identifiés par la marque  $\Delta$  sont critiques pour la sécurité. Ne les remplacer que par une pièce portant le numéro spécifié.

REF. NO.	PART NO.	DESCRIPTION	REMARK	REF. NO.	PART NO.	DESCRIPTION	REMARK
D401	8-719-069-60	ZENER DIODE UDZS-TE17-9.1B		FB605	1-410-397-21	FERRITE 1.1UH	
D402	8-719-110-17	ZENER DIODE RD10ESB2		FB606	1-410-397-21	FERRITE 1.1UH	
D404	8-719-109-97	ZENER DIODE RD6.8ES-B2		FB607	1-410-397-21	FERRITE 1.1UH	
D405	8-719-110-14	ZENER DIODE RD9.1ES-B3		FB608	1-410-397-21	FERRITE 1.1UH	
D406	8-719-110-14	ZENER DIODE RD9.1ES-B3		FB609	1-410-397-21	FERRITE 1.1UH	
D407	8-719-109-97	ZENER DIODE RD6.8ES-B2		FB610	1-410-397-21	FERRITE 1.1UH	
D408	8-719-110-14	ZENER DIODE RD9.1ES-B3					
D409	8-719-921-86	ZENER DIODE MTZJ-13		FB611	1-410-397-21	FERRITE 1.1UH	
D410	8-719-921-54	ZENER DIODE MTZJ-6.2B		FB613	1-410-397-21	FERRITE 1.1UH	
D411	8-719-921-54	ZENER DIODE MTZJ-6.2B		FB614	1-410-397-21	FERRITE 1.1UH	
D412	8-719-109-97	ZENER DIODE RD6.8ES-B2		FB620	1-410-397-21	FERRITE 1.1UH	
D413	8-719-109-97	ZENER DIODE RD6.8ES-B2					
D414	8-719-109-97	ZENER DIODE RD6.8ES-B2					
D501	8-719-110-49	ZENER DIODE RD18ES-B2					
D502	8-719-109-89	ZENER DIODE RD5.6ESB2		IC301	8-752-090-41	IC CXA2139S	
D503	8-719-908-03	DIODE GP08D		IC401	8-752-068-45	IC CXA1855Q	
D506	8-719-302-43	DIODE EL1Z		IC501	8-759-444-83	IC LA7840L	
D507	8-719-302-43	DIODE EL1Z		IC601	8-759-471-81	IC PQ05RD11	
D601	$\Delta$ 8-719-510-63	DIODE D4SB60L-F		IC602	8-759-678-14	IC MC33364DR2	
D602	$\Delta$ 8-719-510-35	DIODE D2SBA60F		IC603	8-759-098-24	IC PQ30RV11	
D604	8-719-911-19	DIODE 1SS119-25		IC604	8-759-098-24	IC PQ30RV11	
D605	8-719-979-50	DIODE EGP30D		IC605	8-749-921-21	IC SI3120C	
D606	8-719-063-74	DIODE D1NL20U-TR2		IC606	$\Delta$ 8-749-016-20	IC STR-F6654-LF1357	
D607	8-719-911-19	DIODE 1SS119-25		IC607	$\Delta$ 8-749-016-19	IC SE135N-LF4	
D608	8-719-110-49	ZENER DIODE RD18ES-B2		IC608	8-759-459-99	IC PQ09RD11	
D609	8-719-064-47	DIODE RN1Z-LF-B1		IC609	8-759-098-24	IC PQ30RV11	
D610	8-719-064-47	DIODE RN1Z-LF-B1		IC610	8-759-098-24	IC PQ30RV11	
D611	8-759-157-40	HTC $\mu$ PC574J		IC611	8-759-198-31	IC uPC1093J-1-T	
D612	8-719-312-10	DIODE RU4AM-T3		IC801	8-759-659-67	IC LA6393DLL	
D613	8-719-978-69	ZENER DIODE DTZ-TT11-16B					
D614	8-719-911-19	DIODE 1SS119-25					
D615	8-719-911-19	DIODE 1SS119-25		J401	1-695-551-11	SOCKET 21P	
D616	8-719-063-74	DIODE D1NL20U-TR2					
D617	8-719-077-12	DIODE RG1C-LFC1					
D618	8-719-063-74	DIODE D1NL20U-TR2					
D619	8-719-043-76	DIODE AK04V0					
D620	8-719-063-74	DIODE D1NL20U-TR2		JR2	1-216-295-11	SHORT 0	
D621	8-719-063-70	DIODE D1NL20U		JR3	1-216-295-11	SHORT 0	
D622	8-719-911-19	DIODE 1SS119-25		JR4	1-216-296-91	SHORT 0	
D623	8-719-073-01	DIODE MA111-(K8).S0		JR5	1-216-295-11	SHORT 0	
D624	8-719-109-72	ZENER DIODE RD3.9ES-B2		JR6	1-216-296-91	SHORT 0	
D625	8-719-067-78	DIODE RN3Z-LF014-302		JR7	1-216-295-11	SHORT 0	
D626	8-719-948-45	DIODE ERA22-08		JR9	1-216-296-91	SHORT 0	
D627	8-719-023-07	DIODE D2S6MF		JR10	1-216-295-11	SHORT 0	
D628	8-719-911-19	DIODE 1SS119-25		JR12	1-216-295-11	SHORT 0	
D629	8-719-911-19	DIODE 1SS119-25		JR13	1-216-296-91	SHORT 0	
D631	8-719-073-01	DIODE MA111-(K8).S0		JR14	1-216-296-91	SHORT 0	
D632	8-719-911-19	DIODE 1SS119-25		JR15	1-216-296-91	SHORT 0	
D633	8-719-911-19	DIODE 1SS119-25		JR16	1-216-296-91	SHORT 0	
D634	8-719-110-88	ZENER DIODE RD39ES-B2		JR17	1-216-296-91	SHORT 0	
D635	8-719-063-70	DIODE D1NL20U		JR18	1-216-296-91	SHORT 0	
D636	8-719-991-33	DIODE 1SS133T-77		JR19	1-216-296-91	SHORT 0	
D637	8-719-982-11	ZENER DIODE MTZJ-4.3B		JR20	1-216-296-91	SHORT 0	
D638	8-719-911-19	DIODE 1SS119-25		JR23	1-216-295-11	SHORT 0	
D639	8-719-110-09	ZENER DIODE RD8.2ES-B3		JR24	1-216-295-11	SHORT 0	
D801	8-719-302-43	DIODE EL1Z		JR25	1-216-295-11	SHORT 0	
D803	8-719-302-43	DIODE EL1Z		JR26	1-216-295-11	SHORT 0	
D804	8-719-908-03	DIODE GP08D		JR130	1-216-295-11	SHORT 0	
D805	8-719-921-44	ZENER DIODE MTZJ-5.1C					
D807	8-719-908-03	DIODE GP08D					
D810	8-719-945-80	DIODE ERC06-15S					
D811	8-719-979-85	DIODE EGP20G		L102	1-408-611-31	INDUCTOR 47UH	
D812	8-719-110-14	ZENER DIODE RD9.1ES-B3		L103	1-408-611-31	INDUCTOR 47UH	
				L104	1-412-002-31	INDUCTOR CHIP 4.7UH	
				L105	1-412-002-31	INDUCTOR CHIP 4.7UH	
				L106	1-408-607-31	INDUCTOR 22UH	
				L107	1-412-002-31	INDUCTOR CHIP 4.7UH	
				L108	1-412-002-31	INDUCTOR CHIP 4.7UH	
				L302	1-414-856-11	INDUCTOR 10UH	
				L303	1-414-856-11	INDUCTOR 10UH	
				L304	1-410-396-41	FERRITE 0.45UH	
FB601	1-410-397-21	FERRITE 1.1UH					
FB602	1-410-397-21	FERRITE 1.1UH					
FB603	1-410-397-21	FERRITE 1.1UH					
FB604	1-410-397-21	FERRITE 1.1UH					



The components identified by shading and mark  $\Delta$  are critical for safety. Replace only with part number specified.

Les composants identifiés par la marque  $\Delta$  sont critiques pour la sécurité. Ne les remplacer que par une pièce portant le numéro spécifié.



REF. NO.	PART NO.	DESCRIPTION	REMARK	REF. NO.	PART NO.	DESCRIPTION	REMARK
L401	1-408-615-31	INDUCTOR 100UH		R107	1-216-025-11	RES-CHIP 100	5% 1/10W
L402	1-408-599-31	INDUCTOR 4.7UH		R108	1-216-025-11	RES-CHIP 100	5% 1/10W
L403	1-414-856-11	INDUCTOR 10UH		R109	1-216-025-11	RES-CHIP 100	5% 1/10W
L501	1-412-533-21	INDUCTOR 47UH		R110	1-216-069-00	RES-CHIP 6.8K	5% 1/10W
L601	1-412-525-31	INDUCTOR 10UH		R111	1-216-121-11	RES-CHIP 1M	5% 1/10W
L602	1-412-533-21	INDUCTOR 47UH		R118	1-216-033-00	RES-CHIP 220	5% 1/10W
L603	1-412-525-31	INDUCTOR 10UH		R119	1-216-105-91	RES-CHIP 220K	5% 1/10W
L604	1-406-983-11	INDUCTOR 1MH		R120	1-216-081-00	RES-CHIP 22K	5% 1/10W
L605	1-412-534-31	INDUCTOR 56UH		R121	1-216-073-00	RES-CHIP 10K	5% 1/10W
L801	1-412-531-31	INDUCTOR 33UH		R122	1-216-073-00	RES-CHIP 10K	5% 1/10W
L802	$\Delta$ 1-419-551-11	COIL, HORIZONTAL LINEARITY (14inch model)		R123	1-216-077-91	RES-CHIP 15K	5% 1/10W
L802	$\Delta$ 1-419-552-11	COIL, HORIZONTAL LINEARITY (21inch model)		R124	1-216-033-00	RES-CHIP 220	5% 1/10W
L803	1-406-677-11	INDUCTOR 10MH		R125	1-216-081-00	RES-CHIP 22K	5% 1/10W
L804	1-412-553-11	INDUCTOR 3.3MH		R126	1-216-105-91	RES-CHIP 220K	5% 1/10W
L805	1-406-989-21	INDUCTOR 10MH	(14inch model)	R127	1-216-073-00	RES-CHIP 10K	5% 1/10W
L805	1-459-111-00	INDUCTOR 10MH	(21inch model)	R128	1-216-073-00	RES-CHIP 10K	5% 1/10W
L808	1-406-984-11	INDUCTOR 1.5MH	(14inch model)	R129	1-216-077-91	RES-CHIP 15K	5% 1/10W
L808	1-419-263-11	COIL, WITH CORE	(21inch model)	R151	1-216-295-11	SHORT 0	
				R152	1-163-021-91	CERAMIC CHIP 0.01UF	10.00% 50V
		<PHOTO COUPLER>		R159	1-216-025-11	RES-CHIP 100	5% 1/10W
PH601	$\Delta$ 8-749-016-21	PHOTO COUPLER TCET1103G		R160	1-216-025-11	RES-CHIP 100	5% 1/10W
PH602	$\Delta$ 8-749-016-21	PHOTO COUPLER TCET1103G		R301	1-216-085-00	RES-CHIP 33K	5% 1/10W (14inch model)
				R301	1-216-057-00	RES-CHIP 2.2K	5% 1/10W (21inch model)
		<IC LINK>		R303	1-216-073-00	RES-CHIP 10K	5% 1/10W
PS601	$\Delta$ 1-532-686-91	LINK, IC (2.7A/150V)		R304	1-216-025-11	RES-CHIP 100	5% 1/10W
PS602	$\Delta$ 1-532-686-91	LINK, IC (2.7A/150V)		R305	1-216-073-00	RES-CHIP 10K	5% 1/10W
PS603	$\Delta$ 1-532-686-91	LINK, IC (2.7A/150V)		R306	1-216-073-00	RES-CHIP 10K	5% 1/10W (21inch model)
PS604	$\Delta$ 1-532-686-91	LINK, IC (2.7A/150V)		R307	1-216-081-00	RES-CHIP 22K	5% 1/10W
				R308	1-216-073-00	RES-CHIP 10K	5% 1/10W (21inch model)
		<TRANSISTOR>		R309	1-216-073-00	RES-CHIP 10K	5% 1/10W
Q101	8-729-026-50	TRANSISTOR 2SA1037AK-T-146-QR		R311	1-216-073-00	RES-CHIP 10K	5% 1/10W (21inch model)
Q102	8-729-026-50	TRANSISTOR 2SA1037AK-T-146-QR		R312	1-216-675-91	METAL CHIP 10K	0.50% 1/10W
Q301	8-729-120-28	TRANSISTOR 2SC1623-L5L6		R313	1-216-061-00	RES-CHIP 3.3K	5% 1/10W
Q302	8-729-120-28	TRANSISTOR 2SC1623-L5L6		R314	1-216-025-11	RES-CHIP 100	5% 1/10W
Q303	8-729-120-28	TRANSISTOR 2SC1623-L5L6		R315	1-216-025-11	RES-CHIP 100	5% 1/10W
Q304	8-729-422-27	TRANSISTOR 2SD601A-Q		R316	1-216-025-11	RES-CHIP 100	5% 1/10W
Q305	8-729-120-28	TRANSISTOR 2SC1623-L5L6 (21inch model)		R317	1-216-025-11	RES-CHIP 100	5% 1/10W
Q306	8-729-120-28	TRANSISTOR 2SC1623-L5L6		R318	1-216-025-11	RES-CHIP 100	5% 1/10W
Q401	8-729-216-22	TRANSISTOR 2SA1162-G		R319	1-216-025-11	RES-CHIP 100	5% 1/10W
Q402	8-729-120-28	TRANSISTOR 2SC1623-L5L6		R320	1-216-049-11	RES-CHIP 1K	5% 1/10W
Q403	8-729-120-28	TRANSISTOR 2SC1623-L5L6		R321	1-216-025-11	RES-CHIP 100	5% 1/10W
Q404	8-729-216-22	TRANSISTOR 2SA1162-G		R322	1-216-041-00	RES-CHIP 470	5% 1/10W
Q405	8-729-120-28	TRANSISTOR 2SC1623-L5L6		R323	1-216-049-11	RES-CHIP 1K	5% 1/10W
Q501	8-729-421-22	TRANSISTOR UN2211		R324	1-216-025-11	RES-CHIP 100	5% 1/10W
Q502	8-729-120-28	TRANSISTOR 2SC1623-L5L6		R325	1-216-041-00	RES-CHIP 470	5% 1/10W
Q601	8-729-120-28	TRANSISTOR 2SC1623-L5L6		R326	1-216-049-11	RES-CHIP 1K	5% 1/10W
Q602	8-729-120-28	TRANSISTOR 2SC1623-L5L6		R327	1-216-025-11	RES-CHIP 100	5% 1/10W
Q603	8-729-026-50	TRANSISTOR 2SA1037AK-T-146-QR		R328	1-216-041-00	RES-CHIP 470	5% 1/10W
Q604	8-729-120-28	TRANSISTOR 2SC1623-L5L6		R329	1-216-049-11	RES-CHIP 1K	5% 1/10W
Q605	8-729-053-40	TRANSISTOR 2SK2733(LBS4SONY)		R330	1-216-025-11	RES-CHIP 100	5% 1/10W
Q606	8-729-120-28	TRANSISTOR 2SC1623-L5L6		R331	1-216-065-91	RES-CHIP 4.7K	5% 1/10W
Q608	8-729-120-28	TRANSISTOR 2SC1623-L5L6		R332	1-216-085-00	RES-CHIP 33K	5% 1/10W
Q609	8-729-120-28	TRANSISTOR 2SC1623-L5L6		R334	1-216-057-00	RES-CHIP 2.2K	5% 1/10W
Q611	8-729-200-17	TRANSISTOR 2SA1091-O		R335	1-247-807-31	CARBON 100	5% 1/4W
Q612	8-729-120-28	TRANSISTOR 2SC1623-L5L6		R336	1-216-057-00	RES-CHIP 2.2K	5% 1/10W
Q801	8-729-038-82	TRANSISTOR 2SK2251-01		R337	1-216-057-00	RES-CHIP 2.2K	5% 1/10W
Q802	8-729-051-82	TRANSISTOR BU4508DX-ON5210		R338	1-216-057-00	RES-CHIP 2.2K	5% 1/10W
Q803	8-729-038-82	TRANSISTOR 2SK2251-01		R340	1-216-097-11	RES-CHIP 100K	5% 1/10W
		<RESISTOR>		R341	1-247-807-31	CARBON 100	5% 1/4W
R101	1-216-069-00	RES-CHIP 6.8K	5% 1/10W	R342	1-216-025-11	RES-CHIP 100	5% 1/10W
R102	1-216-025-11	RES-CHIP 100	5% 1/10W	R343	1-247-807-31	CARBON 100	5% 1/4W
R103	1-216-025-11	RES-CHIP 100	5% 1/10W	R344	1-216-077-91	RES-CHIP 15K	5% 1/10W
R104	1-216-025-11	RES-CHIP 100	5% 1/10W	R346	1-216-073-00	RES-CHIP 10K	5% 1/10W
R105	1-216-025-11	RES-CHIP 100	5% 1/10W	R347	1-216-049-11	RES-CHIP 1K	5% 1/10W
R106	1-216-025-11	RES-CHIP 100	5% 1/10W	R349	1-216-295-11	SHORT 0	

The components identified by shading and mark  $\Delta$  are critical for safety. Replace only with part number specified.

Les composants identifiés par la marque  $\Delta$  sont critiques pour la sécurité. Ne les remplacer que par une pièce portant le numéro spécifié.

**A**

REF. NO.	PART NO.	DESCRIPTION	REMARK	REF. NO.	PART NO.	DESCRIPTION	REMARK
R350	1-216-077-91	RES-CHIP	15K 5% 1/10W	R518	1-216-073-00	RES-CHIP	10K 5% 1/10W
R351	1-216-073-00	RES-CHIP	10K 5% 1/10W	R519	1-249-382-11	CARBON	1.2 5% 1/4W
R352	1-216-041-00	RES-CHIP	470 5% 1/10W	R520	1-216-089-11	RES-CHIP	47K 5% 1/10W
R353	1-216-041-00	RES-CHIP	470 5% 1/10W	R601	1-216-033-00	RES-CHIP	220 5% 1/10W
R354	1-216-041-00	RES-CHIP	470 5% 1/10W	R602	1-216-689-11	METAL CHIP	39K 0.50% 1/10W
R355	1-216-041-00	RES-CHIP	470 5% 1/10W	R603	$\Delta$ 1-218-265-21	METAL	8.2M 5% 1W
R357	1-216-057-00	RES-CHIP	2.2K 5% 1/10W	R605	$\Delta$ 1-220-778-11	FUSIBLE	0.1 10% 1/2W
R358	1-216-059-00	RES-CHIP	2.7K 5% 1/10W	R606	1-247-895-91	CARBON	470K 5% 1/4W
R359	1-216-073-00	RES-CHIP	10K 5% 1/10W	R607	1-216-683-11	METAL CHIP	22K 0.50% 1/10W
R364	1-216-045-00	RES-CHIP	680 5% 1/10W	R608	1-216-077-91	RES-CHIP	15K 5% 1/10W
R365	1-216-073-00	RES-CHIP	10K 5% 1/10W	R609	1-215-917-11	METAL OXIDE	1K 5% 3W
R401	1-216-025-11	RES-CHIP	100 5% 1/10W	R610	1-216-654-11	METAL CHIP	1.3K 0.50% 1/10W
R402	1-216-025-11	RES-CHIP	100 5% 1/10W	R611	1-216-077-91	RES-CHIP	15K 5% 1/10W
R403	1-216-033-00	RES-CHIP	220 5% 1/10W	R612	1-249-480-11	CARBON	3.3 5% 1/2W
R404	1-216-057-00	RES-CHIP	2.2K 5% 1/10W	R613	1-216-037-00	RES-CHIP	330 5% 1/10W
R405	1-216-295-11	SHORT	0	R614	1-249-417-11	CARBON	1K 5% 1/4W
R406	1-216-033-00	RES-CHIP	220 5% 1/10W	R615	1-216-073-00	RES-CHIP	10K 5% 1/10W
R407	1-216-053-00	RES-CHIP	1.5K 5% 1/10W	R616	1-249-417-11	CARBON	1K 5% 1/4W
R408	1-216-033-00	RES-CHIP	220 5% 1/10W	R617	1-216-049-11	RES-CHIP	1K 5% 1/10W
R409	1-216-057-00	RES-CHIP	2.2K 5% 1/10W	R618	1-216-049-11	RES-CHIP	1K 5% 1/10W
R410	1-216-089-11	RES-CHIP	47K 5% 1/10W	R619	1-216-073-00	RES-CHIP	10K 5% 1/10W
R411	1-216-025-11	RES-CHIP	100 5% 1/10W	R620	1-216-077-91	RES-CHIP	15K 5% 1/10W
R412	1-216-025-11	RES-CHIP	100 5% 1/10W	R621	1-249-401-11	CARBON	47 5% 1/4W
R413	1-216-022-00	RES-CHIP	75 5% 1/10W	R622	1-216-073-00	RES-CHIP	10K 5% 1/10W
R414	1-216-022-00	RES-CHIP	75 5% 1/10W	R623	1-216-049-11	RES-CHIP	1K 5% 1/10W
R415	1-216-022-00	RES-CHIP	75 5% 1/10W	R624	1-216-057-00	RES-CHIP	2.2K 5% 1/10W
R416	1-216-022-00	RES-CHIP	75 5% 1/10W	R625	1-216-041-00	RES-CHIP	470 5% 1/10W
R417	1-216-025-11	RES-CHIP	100 5% 1/10W	R626	1-216-065-91	RES-CHIP	4.7K 5% 1/10W
R418	1-216-025-11	RES-CHIP	100 5% 1/10W	R627	1-249-377-11	CARBON	0.47 5% 1/4W
R419	1-216-025-11	RES-CHIP	100 5% 1/10W	R628	1-216-017-91	RES-CHIP	47 5% 1/10W
R420	1-216-025-11	RES-CHIP	100 5% 1/10W	R629	1-216-049-11	RES-CHIP	1K 5% 1/10W
R421	1-216-022-00	RES-CHIP	75 5% 1/10W	R630	1-247-903-00	CARBON	1M 5% 1/4W
R422	1-216-067-00	RES-CHIP	5.6K 5% 1/10W	R631	1-216-013-00	RES-CHIP	33 5% 1/10W
R423	1-216-081-00	RES-CHIP	22K 5% 1/10W	R632	1-216-081-00	RES-CHIP	22K 5% 1/10W
R424	1-247-804-11	CARBON	75 5% 1/4W	R633	1-216-077-91	RES-CHIP	15K 5% 1/10W
R425	1-216-113-00	RES-CHIP	470K 5% 1/10W	R634	1-216-049-11	RES-CHIP	1K 5% 1/10W
R426	1-216-067-00	RES-CHIP	5.6K 5% 1/10W	R635	1-216-077-91	RES-CHIP	15K 5% 1/10W
R427	1-216-037-00	RES-CHIP	330 5% 1/10W	R636	1-215-927-00	METAL OXIDE	47K 5% 3W
R428	1-216-081-00	RES-CHIP	22K 5% 1/10W	R637	1-216-009-91	RES-CHIP	22 5% 1/10W
R429	1-216-037-00	RES-CHIP	330 5% 1/10W	R638	1-249-405-11	CARBON	100 5% 1/4W
R431	1-216-065-91	RES-CHIP	4.7K 5% 1/10W	R639	1-216-055-00	RES-CHIP	1.8K 5% 1/10W
R432	1-216-057-00	RES-CHIP	2.2K 5% 1/10W	R640	1-216-061-00	RES-CHIP	3.3K 5% 1/10W
R434	1-216-097-11	RES-CHIP	100K 5% 1/10W	R641	1-216-025-11	RES-CHIP	100 5% 1/10W
R435	1-216-057-00	RES-CHIP	2.2K 5% 1/10W	R642	1-216-675-91	METAL CHIP	10K 0.50% 1/4W
R436	1-216-095-00	RES-CHIP	82K 5% 1/10W	R643	1-216-695-11	METAL CHIP	68K 0.50% 1/4W
R437	1-216-057-00	RES-CHIP	2.2K 5% 1/10W	R644	1-216-057-00	RES-CHIP	2.2K 5% 1/10W
R438	1-216-067-00	RES-CHIP	5.6K 5% 1/10W	R645	1-216-665-11	METAL CHIP	3.9K 0.50% 1/10W
R439	1-216-067-00	RES-CHIP	5.6K 5% 1/10W	R646	1-216-045-00	RES-CHIP	680 5% 1/10W
R441	1-216-025-11	RES-CHIP	100 5% 1/10W	R647	1-249-389-11	CARBON	4.7 5% 1/4W
R442	1-216-033-00	RES-CHIP	220 5% 1/10W	R648	1-216-361-00	METAL OXIDE	0.22 5% 2W
R443	1-216-025-11	RES-CHIP	100 5% 1/10W	R649	1-216-361-00	METAL OXIDE	0.22 5% 2W
R444	1-216-025-11	RES-CHIP	100 5% 1/10W	R650	1-216-089-11	RES-CHIP	47K 5% 1/10W
R445	1-249-413-11	CARBON	470 5% 1/4W	R651	1-216-013-00	RES-CHIP	33 5% 1/10W
R446	1-216-041-00	RES-CHIP	470 5% 1/10W	R652	1-216-045-00	RES-CHIP	680 5% 1/10W
R447	1-216-025-11	RES-CHIP	100 5% 1/10W	R653	1-216-669-11	METAL CHIP	5.6K 0.50% 1/10W
R448	1-216-089-11	RES-CHIP	47K 5% 1/10W	R655	1-216-073-00	RES-CHIP	10K 5% 1/10W
R449	1-216-089-11	RES-CHIP	47K 5% 1/10W	R656	1-216-077-91	RES-CHIP	15K 5% 1/10W
R502	1-216-089-11	RES-CHIP	47K 5% 1/10W	R657	1-215-469-00	METAL	100K 1% 1/4W
R503	1-216-081-00	RES-CHIP	22K 5% 1/10W	R658	1-216-073-00	RES-CHIP	10K 5% 1/10W
R504	1-216-097-11	RES-CHIP	100K 5% 1/10W	R659	1-216-077-91	RES-CHIP	15K 5% 1/10W
R507	1-216-049-11	RES-CHIP	1K 5% 1/10W	R660	1-216-033-00	RES-CHIP	220 5% 1/10W
R508	1-216-049-11	RES-CHIP	1K 5% 1/10W	R661	1-216-033-00	RES-CHIP	220 5% 1/10W
R510	1-216-097-11	RES-CHIP	100K 5% 1/10W	R662	1-249-409-11	CARBON	220 5% 1/4W
R512	1-215-888-00	METAL OXIDE	220 5% 2W	R663	1-249-409-11	CARBON	220 5% 1/4W
R513	1-216-065-91	RES-CHIP	4.7K 5% 1/10W	R665	1-260-123-11	CARBON	100K 5% 1/2W
R514	1-216-073-00	RES-CHIP	10K 5% 1/10W	R666	1-216-057-00	RES-CHIP	2.2K 5% 1/10W
R515	1-216-377-11	METAL OXIDE	4.7 5% 2W	R667	1-216-051-00	RES-CHIP	1.2K 5% 1/10W
R516	1-249-385-11	CARBON	2.2 5% 1/4W	R668	1-216-488-11	METAL OXIDE	18K 5% 3W
R517	1-216-065-91	RES-CHIP	4.7K 5% 1/10W	R669	1-216-665-11	METAL CHIP	3.9K 0.50% 1/10W
				R670	1-216-679-11	METAL CHIP	15K 0.50% 1/10W

The components identified by shading and mark  $\Delta$  are critical for safety. Replace only with part number specified.

Les composants identifiés par la marque  $\Delta$  sont critiques pour la sécurité. Ne les remplacer que par une pièce portant le numéro spécifié.

**A CVM**

REF. NO.	PART NO.	DESCRIPTION	REMARK	REF. NO.	PART NO.	DESCRIPTION	REMARK
R671	1-216-033-00	RES-CHIP	220 5% 1/10W	R838	1-215-886-11	METAL OXIDE	100 5% 2W (21inch model)
R673	1-216-113-00	RES-CHIP	470K 5% 1/10W	R839	1-216-349-00	METAL OXIDE	1 5% 1W
R674	1-216-488-11	METAL OXIDE	18K 5% 3W	R841	1-260-338-51	CARBON	6.8K 5% 1/2W
R675	1-216-049-11	RES-CHIP	1K 5% 1/10W	R842	1-215-898-11	METAL OXIDE	10K 5% 2W
R676	1-216-101-00	RES-CHIP	150K 5% 1/10W	R843	1-260-083-11	CARBON	47 5% 1/2W
R677	1-202-962-11	CEMENTED	3.3 5% 10W (14inch model)			<RELAY>	
R678	1-216-081-00	RES-CHIP	22K 5% 1/10W	RY601	$\Delta$ 1-755-198-12	RELAY, AC POWER	
R679	1-216-368-11	METAL OXIDE	0.82 5% 2W	RY602	$\Delta$ 1-755-198-12	RELAY, AC POWER	
R680	1-247-883-00	CARBON	150K 5% 1/4W	RY603	$\Delta$ 1-755-245-11	RELAY, AC POWER	
R681	1-216-065-91	RES-CHIP	4.7K 5% 1/10W			<SWITCH>	
R682	1-247-885-00	CARBON	180K 5% 1/4W	S801	1-572-707-11	SWITCH, LEVER (H-CENT)	
R683	1-247-711-11	CARBON	680 5% 1/4W			<TRANSFORMER>	
R684	1-216-073-00	RES-CHIP	10K 5% 1/10W	T602	$\Delta$ 1-435-635-11	TRANSFORMER, CONVERTER (SRT)	
R685	1-216-081-00	RES-CHIP	22K 5% 1/10W	T604	$\Delta$ 1-435-634-11	TRANSFORMER, CONVERTER (SRT)	
R686	1-216-049-11	RES-CHIP	1K 5% 1/10W	T801	$\Delta$ 8-598-852-00	TRANSFORMER ASSY, FLYBACK (NX-1912/M)	
R687	1-216-073-00	RES-CHIP	10K 5% 1/10W	T801	$\Delta$ 1-453-314-11	TRANSFORMER ASSY, FLYBACK	(14inch model)
R688	1-249-435-11	CARBON	33K 5% 1/4W	T803	1-437-210-11	TRANSFORMER, HORIZONTAL DRIVE	(21inch model)
R689	1-216-049-11	RES-CHIP	1K 5% 1/10W			<THERMISTOR>	
R801	1-218-768-11	METAL CHIP	470K 0.50% 1/10W (14inch model)	TH601	$\Delta$ 1-803-586-11	THERMISTOR, NTC	
R801	1-218-764-11	METAL CHIP	330K 0.50% 1/10W (21inch model)	THP601	$\Delta$ 1-809-827-11	THERMISTOR, POSITIVE	
R802	1-216-447-00	METAL OXIDE	27 5% 2W (14inch model)			<TUNER>	
R802	1-215-884-11	METAL OXIDE	47 5% 2W (21inch model)	TU101	8-598-528-00	FRONTEND BTF-EU602 (VTR)	(UK model)
R803	1-249-377-11	CARBON	0.47 5% 1/4W	TU101	8-598-532-00	FRONTEND BTF-EC402 (VTR)	(AEP/ESP model)
R805	1-214-775-00	METAL	82K 1% 1/4W (14inch model)	TU101	8-598-536-00	FRONTEND BTF-EF412 (VTR)	(FR model)
R805	1-214-765-00	METAL	33K 1% 1/4W (21inch model)	TU102	8-598-528-00	FRONTEND BTF-EU602 (TV)	(UK model)
R806	1-249-377-11	CARBON	0.47 5% 1/4W	TU102	8-598-532-00	FRONTEND BTF-EC402 (TV)	(AEP/ESP model)
R807	1-215-887-00	METAL OXIDE	150 5% 2W	TU102	8-598-536-00	FRONTEND BTF-EF412 (TV)	(FR model)
R808	1-214-775-00	METAL	82K 1% 1/4W (14inch model)			<CRYSTAL>	
R808	1-214-907-00	METAL	56K 1% 1/2W (21inch model)	X301	1-567-504-11	OSCILLATOR, CRYSTAL	
R809	1-216-085-00	RES-CHIP	33K 5% 1/10W	X302	1-567-505-11	OSCILLATOR, CRYSTAL	
R810	1-216-683-11	METAL CHIP	22K 0.50% 1/10W (21inch model)			*****	
R811	1-216-057-00	RES-CHIP	2.2K 5% 1/10W			* A-1639-006-ACVM BOARD, COMPLETE (14inch model)	
R812	1-216-687-11	METAL CHIP	33K 0.50% 1/10W			*****	
R814	1-216-295-11	SHORT	0			* A-1639-005-ACVM BOARD, COMPLETE (21inch model)	
R816	1-216-687-11	METAL CHIP	33K 0.50% 1/10W			*****	
R817	1-216-057-00	RES-CHIP	2.2K 5% 1/10W			4-352-844-01	PIN, LEAD, COATING (LP701, LP702, LP703)
R818	1-216-681-11	METAL CHIP	18K 0.50% 1/10W			4-382-854-01	SCREW (M3X8), P, SW (+) (Q1711, Q1712)
R821	1-249-391-11	CARBON	6.8 5% 1/4W			<CAPACITOR>	
R822	1-249-411-11	CARBON	330 5% 1/4W	C701	1-137-043-11	MYLAR	0.0047UF 10.00% 400V
R823	1-216-677-11	METAL CHIP	12K 0.50% 1/10W	C702	1-163-251-11	CERAMIC CHIP	100PF 5.00% 50V (14inch model)
R824	1-218-753-11	METAL CHIP	110K 0.50% 1/10W (14inch model)	C702	1-163-255-11	CERAMIC CHIP	150PF 5.00% 50V (21inch model)
R824	1-216-699-91	METAL CHIP	100K 0.50% 1/10W (21inch model)	C703	1-163-251-11	CERAMIC CHIP	100PF 5.00% 50V (14inch model)
R825	1-216-073-00	RES-CHIP	10K 5% 1/10W	C703	1-163-255-11	CERAMIC CHIP	150PF 5.00% 50V (21inch model)
R826	1-215-892-11	METAL OXIDE	1K 5% 2W	C704	1-163-021-91	CERAMIC CHIP	0.01UF 10.00% 50V
R827	1-216-073-00	RES-CHIP	10K 5% 1/10W	C705	1-163-021-91	CERAMIC CHIP	0.01UF 10.00% 50V
R828	1-216-097-11	RES-CHIP	100K 5% 1/10W				
R830	1-216-689-11	METAL CHIP	39K 0.50% 1/10W (14inch model)				
R830	1-216-691-11	METAL CHIP	47K 0.50% 1/10W (21inch model)				
R831	1-218-769-11	METAL CHIP	510K 0.50% 1/10W (14inch model)				
R831	1-216-696-11	METAL CHIP	75K 0.50% 1/10W (21inch model)				
R832	1-216-675-91	METAL CHIP	10K 0.50% 1/10W (14inch model)				
R832	1-216-661-11	METAL CHIP	2.7K 0.50% 1/10W (21inch model)				
R833	1-216-699-91	METAL CHIP	100K 0.50% 1/10W				
R835	1-216-057-00	RES-CHIP	2.2K 5% 1/10W				
R837	1-216-683-11	METAL CHIP	22K 0.50% 1/10W				



The components identified by shading and mark  $\Delta$  are critical for safety. Replace only with part number specified.

Les composants identifiés par la marque  $\Delta$  sont critiques pour la sécurité. Ne les remplacer que par une pièce portant le numéro spécifié.

REF. NO.	PART NO.	DESCRIPTION	REMARK
C708	1-162-114-00	CERAMIC 0.0047UF	2KV
C710	1-136-189-00	MYLAR 0.1UF	10.00% 250V
C712	1-163-251-11	CERAMIC CHIP 100PF	5.00% 50V (14inch model)
C712	1-163-255-11	CERAMIC CHIP 150PF	5.00% 50V (21inch model)
C713	1-163-021-91	CERAMIC CHIP 0.01UF	10.00% 50V
C714	1-104-665-11	ELECT 100UF	20.00% 16V
C715	1-163-113-00	CERAMIC CHIP 68PF	5.00% 50V (21inch model)
C716	1-163-113-00	CERAMIC CHIP 68PF	5.00% 50V (21inch model)
C717	1-163-005-11	CERAMIC CHIP 470PF	10.00% 50V
C718	1-163-005-11	CERAMIC CHIP 470PF	10.00% 50V
C719	1-163-005-11	CERAMIC CHIP 470PF	10.00% 50V
C720	1-163-113-00	CERAMIC CHIP 68PF	5.00% 50V (21inch model)
C723	1-163-251-11	CERAMIC CHIP 100PF	5.00% 50V
C724	1-163-251-11	CERAMIC CHIP 100PF	5.00% 50V
C725	1-163-251-11	CERAMIC CHIP 100PF	5.00% 50V
C1701	1-104-665-11	ELECT 100UF	20.00% 16V
C1702	1-163-235-11	CERAMIC CHIP 22PF	5.00% 50V (21inch model)
C1703	1-126-925-11	ELECT 470UF	20.00% 10V
C1704	1-163-021-91	CERAMIC CHIP 0.01UF	10.00% 50V
C1705	1-163-239-11	CERAMIC CHIP 33PF	5.00% 50V
C1706	1-126-925-11	ELECT 470UF	20.00% 10V
C1709	1-126-964-11	ELECT 10UF	20.00% 50V
C1710	1-106-375-12	MYLAR 0.022UF	10.00% 250V
C1711	1-106-375-12	MYLAR 0.022UF	10.00% 250V
C1712	1-136-203-11	MYLAR 0.01UF	10.00% 250V
C1713	1-104-664-11	ELECT 47UF	20.00% 25V
C1715	1-104-999-11	MYLAR 0.1UF	5.00% 200V
C1716	1-107-639-11	ELECT 47UF	20.00% 160V
C1717	1-104-664-11	ELECT 47UF	20.00% 25V
C1803	1-163-033-91	CERAMIC CHIP 0.022UF	50V (21inch model)
C1804	1-164-346-11	CERAMIC CHIP 1UF	16V (21inch model)
<CONNECTOR>			
CN702	1-695-915-11	TAB (CONTACT)	
CN703	* 1-564-509-11	PLUG, CONNECTOR 6P	
CN706	1-695-915-11	TAB (CONTACT)	
CN707	* 1-564-508-11	PLUG, CONNECTOR 5P	
CN1703	* 1-564-506-11	PLUG, CONNECTOR 3P	
CN1705	* 1-564-509-11	PLUG, CONNECTOR 6P	
CN1801	* 1-564-506-11	PLUG, CONNECTOR 3P	(21inch model)
<DIODE>			
D702	8-719-988-61	DIODE 1SS355TE-17	
D703	8-719-988-61	DIODE 1SS355TE-17	
D704	8-719-988-61	DIODE 1SS355TE-17	
D705	8-719-988-61	DIODE 1SS355TE-17	
D706	8-719-988-61	DIODE 1SS355TE-17	
D707	8-719-988-61	DIODE 1SS355TE-17	
D708	8-719-988-61	DIODE 1SS355TE-17	
D709	8-719-988-61	DIODE 1SS355TE-17	
D710	8-719-988-61	DIODE 1SS355TE-17	
D711	8-719-988-61	DIODE 1SS355TE-17	
D712	8-719-988-61	DIODE 1SS355TE-17	
D714	8-719-988-61	DIODE 1SS355TE-17	
D715	8-719-988-61	DIODE 1SS355TE-17	
D716	8-719-988-61	DIODE 1SS355TE-17	
D717	8-719-988-61	DIODE 1SS355TE-17	
D718	8-719-988-61	DIODE 1SS355TE-17	
D719	8-719-988-61	DIODE 1SS355TE-17	
D721	8-719-988-61	DIODE 1SS355TE-17	
D722	8-719-988-61	DIODE 1SS355TE-17	

REF. NO.	PART NO.	DESCRIPTION	REMARK
D1703	8-719-988-61	DIODE 1SS355TE-17	
D1704	1-216-295-11	SHORT 0	
D1705	1-216-295-11	SHORT 0	
D1706	8-719-988-61	DIODE 1SS355TE-17	
D1707	8-719-988-61	DIODE 1SS355TE-17	
D1710	8-719-109-89	ZENER DIODE RD5.6ESB2	
D1711	8-719-109-89	ZENER DIODE RD5.6ESB2	
D1801	8-719-977-28	ZENER DIODE DTZ10B	(21inch model)
D1802	8-719-977-28	ZENER DIODE DTZ10B	(21inch model)
D1803	8-719-977-28	ZENER DIODE DTZ10B	(21inch model)
<FUSE>			
F1701	$\Delta$ 1-576-470-21	LINK, FUSE (6.3A)	
<FERRITE BEAD>			
FB1701	1-412-911-11	FERRITE 0UH	
<IC>			
IC1801	8-759-603-37	IC M5216P	(21inch model)
<JACK>			
J701	$\Delta$ 1-251-595-11	SOCKET, PICTURE TUBE	
<COIL>			
L701	1-412-947-11	INDUCTOR 4.7UH	(21inch model)
L702	1-412-947-11	INDUCTOR 4.7UH	(21inch model)
L703	1-412-530-31	INDUCTOR 27UH	(14inch model)
L703	1-412-533-21	INDUCTOR 47UH	(21inch model)
L704	1-414-183-41	INDUCTOR 10UH	
L705	1-412-947-11	INDUCTOR 4.7UH	(21inch model)
L706	1-414-183-41	INDUCTOR 10UH	
L1701	1-414-183-41	INDUCTOR 10UH	
L1703	1-412-953-11	INDUCTOR 15UH	(21inch model)
L1704	1-412-545-11	INDUCTOR 470UH	
<TRANSISTOR>			
Q701	8-729-046-28	TRANSISTOR BF420-126	
Q702	8-729-120-28	TRANSISTOR 2SC1623-L5L6	
Q703	8-729-046-28	TRANSISTOR BF420-126	
Q704	8-729-200-17	TRANSISTOR 2SA1091-O	
Q705	8-729-120-28	TRANSISTOR 2SC1623-L5L6	
Q706	8-729-046-28	TRANSISTOR BF420-126	
Q707	8-729-200-17	TRANSISTOR 2SA1091-O	
Q708	8-729-120-28	TRANSISTOR 2SC1623-L5L6	
Q709	8-729-046-28	TRANSISTOR BF420-126	
Q710	8-729-200-17	TRANSISTOR 2SA1091-O	
Q711	8-729-120-28	TRANSISTOR 2SC1623-L5L6	
Q712	8-729-046-28	TRANSISTOR BF420-126	
Q713	8-729-046-28	TRANSISTOR BF420-126	
Q714	8-729-026-49	TRANSISTOR 2SA1037AK-T146-R	
Q715	8-729-200-17	TRANSISTOR 2SA1091-O	
Q716	8-729-200-17	TRANSISTOR 2SA1091-O	
Q717	8-729-200-17	TRANSISTOR 2SA1091-O	
Q1701	8-729-120-28	TRANSISTOR 2SC1623-L5L6	
Q1704	8-729-120-28	TRANSISTOR 2SC1623-L5L6	
Q1705	8-729-120-28	TRANSISTOR 2SC1623-L5L6	
Q1706	8-729-119-78	TRANSISTOR 2SC2785-HFE	
Q1707	8-729-119-78	TRANSISTOR 2SC2785-HFE	
Q1708	8-729-026-39	TRANSISTOR 2SA933AS-QT	
Q1709	8-729-049-09	TRANSISTOR BC327-25	
Q1710	8-729-049-10	TRANSISTOR BC337-25	
Q1711	8-729-017-05	TRANSISTOR 2SA1837	
Q1712	8-729-017-06	TRANSISTOR 2SC4793	

The components identified by shading and mark  $\triangle$  are critical for safety. Replace only with part number specified.

Les composants identifiés par la marque  $\triangle$  sont critiques pour la sécurité. Ne les remplacer que par une pièce portant le numéro spécifié.



REF. NO.	PART NO.	DESCRIPTION	REMARK	REF. NO.	PART NO.	DESCRIPTION	REMARK
		<RESISTOR>		R1728	1-249-407-11	CARBON 150	5% 1/4W
R701	1-247-895-91	CARBON 470K	5% 1/4W	R1729	1-249-387-11	CARBON 3.3	5% 1/4W
R702	1-215-900-11	METAL OXIDE 22K	5% 2W	R1730	1-249-387-11	CARBON 3.3	5% 1/4W
R703	1-247-807-31	CARBON 100	5% 1/4W	R1731	1-216-487-11	METAL OXIDE 12K	5% 3W
R705	1-215-871-11	METAL OXIDE 2.2K	5% 1W	R1732	1-215-867-00	METAL OXIDE 470	5% 1W
R706	1-216-033-00	RES-CHIP 220	5% 1/10W	R1801	1-216-049-11	RES-CHIP 1K	5% 1/10W (21inch model)
R707	1-216-043-91	RES-CHIP 560	5% 1/10W (14inch model)	R1802	1-216-049-11	RES-CHIP 1K	5% 1/10W (21inch model)
R707	1-216-039-00	RES-CHIP 390	5% 1/10W (21inch model)	R1805	1-216-073-00	RES-CHIP 10K	5% 1/10W (21inch model)
R708	1-216-017-91	RES-CHIP 47	5% 1/10W	R1806	1-216-117-00	RES-CHIP 680K	5% 1/10W (21inch model)
R709	1-216-049-11	RES-CHIP 1K	5% 1/10W	R1807	1-216-073-00	RES-CHIP 10K	5% 1/10W (21inch model)
R710	1-216-113-00	RES-CHIP 470K	5% 1/10W	R1808	1-216-073-00	RES-CHIP 10K	5% 1/10W (21inch model)
R712	1-215-871-11	METAL OXIDE 2.2K	5% 1W	R1809	1-216-073-00	RES-CHIP 10K	5% 1/10W (21inch model)
R713	1-216-113-00	RES-CHIP 470K	5% 1/10W	R1810	1-216-073-00	RES-CHIP 10K	5% 1/10W (21inch model)
R714	1-215-900-11	METAL OXIDE 22K	5% 2W			<VARIABLE RESISTOR>	
R715	1-247-807-31	CARBON 100	5% 1/4W			RV702 $\triangle$ 1-241-656-21	RES, ADJ, METAL FILM 110M (H-STAT)
R716	1-216-033-00	RES-CHIP 220	5% 1/10W			*****	
R717	1-216-043-91	RES-CHIP 560	5% 1/10W (14inch model)				
R717	1-216-039-00	RES-CHIP 390	5% 1/10W (21inch model)				
R718	1-202-814-11	SOLID 33K	10% 1/2W				
R719	1-216-017-91	RES-CHIP 47	5% 1/10W				
R721	1-247-807-31	CARBON 100	5% 1/4W				
R722	1-216-049-11	RES-CHIP 1K	5% 1/10W				
R723	1-216-049-11	RES-CHIP 1K	5% 1/10W				
R725	1-216-065-91	RES-CHIP 4.7K	5% 1/10W				
R726	1-215-871-11	METAL OXIDE 2.2K	5% 1W				
R727	1-216-033-00	RES-CHIP 220	5% 1/10W				
R729	1-216-043-11	RES-CHIP 560	5% 1/10W (14inch model)				
R729	1-216-039-00	RES-CHIP 390	5% 1/10W (21inch model)				
R730	1-216-017-91	RES-CHIP 47	5% 1/10W				
R732	1-216-121-91	RES-CHIP 1M	5% 1/10W				
R733	1-216-097-11	RES-CHIP 100K	5% 1/10W				
R734	1-247-807-31	CARBON 100	5% 1/4W				
R736	1-215-900-11	METAL OXIDE 22K	5% 2W				
R737	1-216-117-00	RES-CHIP 680K	5% 1/10W				
R741	1-202-549-00	SOLID 100	20% 1/2W				
R746	1-216-049-11	RES-CHIP 1K	5% 1/10W				
R750	1-216-049-11	RES-CHIP 1K	5% 1/10W				
R751	1-216-049-11	RES-CHIP 1K	5% 1/10W				
R1701	1-216-033-00	RES-CHIP 220	5% 1/10W				
R1702	1-216-049-11	RES-CHIP 1K	5% 1/10W				
R1703	1-247-807-31	CARBON 100	5% 1/4W				
R1704	1-247-807-31	CARBON 100	5% 1/4W				
R1705	1-216-049-11	RES-CHIP 1K	5% 1/10W				
R1706	1-216-049-11	RES-CHIP 1K	5% 1/10W				
R1707	1-249-436-11	CARBON 39K	5% 1/4W				
R1708	1-249-436-11	CARBON 39K	5% 1/4W				
R1709	1-216-025-11	RES-CHIP 100	5% 1/10W				
R1710	1-216-057-00	RES-CHIP 2.2K	5% 1/10W				
R1711	1-216-065-91	RES-CHIP 4.7K	5% 1/10W				
R1712	1-216-041-00	RES-CHIP 470	5% 1/10W				
R1713	1-216-065-91	RES-CHIP 4.7K	5% 1/10W				
R1714	1-216-019-00	RES-CHIP 56	5% 1/10W				
R1715	1-216-029-00	RES-CHIP 150	5% 1/10W				
R1716	1-216-031-00	RES-CHIP 180	5% 1/10W				
R1717	1-216-053-00	RES-CHIP 1.5K	5% 1/10W				
R1718	1-260-091-11	CARBON 220	5% 1/2W				
R1719	1-216-051-00	RES-CHIP 1.2K	5% 1/10W				
R1721	1-216-051-00	RES-CHIP 1.2K	5% 1/10W				
R1722	1-216-065-91	RES-CHIP 4.7K	5% 1/10W				
R1723	1-216-107-00	RES-CHIP 270K	5% 1/10W				
R1724	1-216-107-00	RES-CHIP 270K	5% 1/10W				
R1725	1-216-065-91	RES-CHIP 4.7K	5% 1/10W				
R1726	1-249-433-11	CARBON 22K	5% 1/4W				
R1727	1-249-407-11	CARBON 150	5% 1/4W				

# MA10

# VIDEO BLOCK

REF. NO.	PART NO.	DESCRIPTION	REMARK	REF. NO.	PART NO.	DESCRIPTION	REMARK
* A-1635-042-AMA10 BOARD, COMPLETE (KV-14/21FV1D,-14/21FV1U) *****				C415	1-130-489-00	MYLAR 0.033UF	5.00% 50V
				C416	1-163-031-11	CERAMIC CHIP 0.01UF	50V
* A-1635-043-AMA10 BOARD, COMPLETE (KV-14/21FV1E) *****				C417	1-128-551-11	ELECT 22UF	20.00% 25V
				C418	1-130-488-00	MYLAR 0.027UF	5.00% 50V
				C419	1-126-961-11	ELECT 2.2UF	20.00% 50V
				C421	1-104-665-11	ELECT 100UF	20.00% 10V
* A-1635-044-AMA10 BOARD, COMPLETE (KV-14/21FV1B) *****				C422	1-163-018-00	CERAMIC CHIP 0.0056UF	10.00% 50V
3-960-273-11		SPACER, TOP END (Q452, Q453)		C424	1-126-960-11	ELECT 1UF	20.00% 50V
* 3-960-274-01		SPACER, LED (D451)		C425	1-163-038-11	CERAMIC CHIP 0.1UF	25V
4-352-844-01		PIN, LEAD, COATING (LP001, LP002)		C430	1-163-227-11	CERAMIC CHIP 10PF	0.50PF 50V
* 4-374-846-01		COVER, CAPACITOR, CAP TYPE (VDR601)		C431	1-163-231-11	CERAMIC CHIP 15PF	5.00% 50V
4-382-854-01		SCREW (M3X8), P, SW (+) (IC201)		C432	1-163-038-11	CERAMIC CHIP 0.1UF	25V
		<CAPACITOR>		C435	1-163-038-11	CERAMIC CHIP 0.1UF	25V
C001	1-163-104-00	CERAMIC CHIP 30PF	5.00% 50V	C436	1-124-584-00	ELECT 100UF	20.00% 10V
C002	1-163-235-11	CERAMIC CHIP 22PF	5.00% 50V	C441	1-163-031-11	CERAMIC CHIP 0.01UF	50V
C004	1-163-031-11	CERAMIC CHIP 0.01UF	50V	C455	1-126-924-11	ELECT 330UF	20.00% 6.3V
C005	1-163-009-11	CERAMIC CHIP 0.001UF	10.00% 50V	C456	1-163-009-11	CERAMIC CHIP 0.001UF	10.00% 50V
C006	1-163-241-11	CERAMIC CHIP 39PF	5.00% 50V	C457	1-163-009-11	CERAMIC CHIP 0.001UF	10.00% 50V
C007	1-163-241-11	CERAMIC CHIP 39PF	5.00% 50V	C458	1-163-009-11	CERAMIC CHIP 0.001UF	10.00% 50V
C008	1-107-823-11	CERAMIC CHIP 0.47UF	10.00% 16V	C460	1-163-009-11	CERAMIC CHIP 0.001UF	10.00% 50V
C009	1-163-009-11	CERAMIC CHIP 0.001UF	10.00% 50V	C701	1-163-033-91	CERAMIC CHIP 0.022UF	50V
C010	1-163-989-11	CERAMIC CHIP 0.033UF	10.00% 25V	C702	1-163-031-11	CERAMIC CHIP 0.01UF	50V
C013	1-126-964-11	ELECT 10UF	(except ESP model) 20.00% 50V	C705	1-163-033-91	CERAMIC CHIP 0.022UF	50V
C014	1-163-038-11	CERAMIC CHIP 0.1UF	25V	C706	1-163-235-11	CERAMIC CHIP 22PF	5.00% 50V
C015	1-124-584-00	ELECT 100UF	20.00% 10V	C707	1-163-033-91	CERAMIC CHIP 0.022UF	50V
C016	1-163-037-11	CERAMIC CHIP 0.022UF	10.00% 50V	C709	1-163-241-11	CERAMIC CHIP 39PF	5.00% 50V
C017	1-163-255-11	CERAMIC CHIP 150PF	(except ESP model) 5.00% 50V	C711	1-163-033-91	CERAMIC CHIP 0.022UF	50V
C018	1-163-809-11	CERAMIC CHIP 0.047UF	(except ESP model) 10.00% 25V	C712	1-163-033-91	CERAMIC CHIP 0.022UF	50V
C019	1-163-989-11	CERAMIC CHIP 0.033UF	(except ESP model) 10.00% 25V	C713	1-163-241-11	CERAMIC CHIP 39PF	5.00% 50V
C021	1-163-009-11	CERAMIC CHIP 0.001UF	10.00% 50V	C716	1-163-033-91	CERAMIC CHIP 0.022UF	50V
C022	1-163-009-11	CERAMIC CHIP 0.001UF	10.00% 50V	C717	1-163-031-11	CERAMIC CHIP 0.01UF	50V
C024	1-163-259-91	CERAMIC CHIP 220PF	5.00% 50V	C718	1-163-031-11	CERAMIC CHIP 0.01UF	50V
C025	1-163-259-91	CERAMIC CHIP 220PF	5.00% 50V	C719	1-163-038-11	CERAMIC CHIP 0.1UF	25V
C033	1-124-584-00	ELECT 100UF	(except ESP model) 20.00% 10V	C720	1-104-665-11	ELECT 100UF	20.00% 10V
C099	1-163-038-11	CERAMIC CHIP 0.1UF	(except ESP model) 25V	C722	1-163-038-11	CERAMIC CHIP 0.1UF	25V
C208	1-126-963-11	ELECT 4.7UF	20.00% 50V	C723	1-163-038-11	CERAMIC CHIP 0.1UF	25V
C209	1-124-252-00	ELECT 0.33UF	20.00% 50V	C724	1-104-665-11	ELECT 100UF	20.00% 10V
C210	1-163-031-11	CERAMIC CHIP 0.01UF	50V	C725	1-163-038-91	CERAMIC CHIP 0.1UF	25V
C211	1-119-821-11	ELECT MELF 2.2UF	20% 50V	C726	1-163-031-11	CERAMIC CHIP 0.01UF	50V
C214	1-104-666-11	ELECT 220UF	20.00% 25V	C727	1-163-031-11	CERAMIC CHIP 0.01UF	50V
C216	1-126-964-11	ELECT 10UF	20.00% 50V	C728	1-163-031-11	CERAMIC CHIP 0.01UF	50V
C217	1-126-959-11	ELECT 0.47UF	20.00% 50V	C801	1-164-492-11	CERAMIC CHIP 0.15UF	10.00% 16V
C218	1-126-942-61	ELECT 1000UF	20.00% 25V	C804	1-163-241-11	CERAMIC CHIP 39PF	5.00% 50V
C219	1-163-038-11	CERAMIC CHIP 0.1UF	25V	C807	1-163-227-11	CERAMIC CHIP 10PF	0.50PF 50V
C220	1-126-942-61	ELECT 1000UF	20.00% 25V	C808	1-163-031-11	CERAMIC CHIP 0.01UF	50V
C258	1-163-038-11	CERAMIC CHIP 0.1UF	25V	C813	1-163-251-11	CERAMIC CHIP 100PF	5.00% 50V
C259	1-107-791-11	DOUBLE LAYER 0.33F	5.5V	C815	1-163-239-11	CERAMIC CHIP 33PF	5.00% 50V
C260	1-104-665-11	ELECT 100UF	20.00% 10V	C816	1-163-037-11	CERAMIC CHIP 0.022UF	10.00% 50V
C262	1-163-091-00	CERAMIC CHIP 8PF	0.25PF 50V	C817	1-163-031-11	CERAMIC CHIP 0.01UF	50V
C263	1-163-091-00	CERAMIC CHIP 8PF	0.25PF 50V	C818	1-163-031-11	CERAMIC CHIP 0.01UF	50V
C401	1-163-035-00	CERAMIC CHIP 0.047UF	50V	C819	1-163-131-00	CERAMIC CHIP 390PF	5.00% 50V
C402	1-104-664-11	ELECT 47UF	20.00% 10V	C820	1-163-809-11	CERAMIC CHIP 0.047UF	10.00% 25V
C405	1-104-664-11	ELECT 47UF	20.00% 16V	C822	1-128-551-11	ELECT 22UF	20.00% 25V
C406	1-163-031-11	CERAMIC CHIP 0.01UF	50V	C823	1-126-960-11	ELECT 1UF	20.00% 50V
C407	1-163-031-11	CERAMIC CHIP 0.01UF	50V	C824	1-163-031-11	CERAMIC CHIP 0.01UF	50V
C408	1-164-004-11	CERAMIC CHIP 0.1UF	10.00% 25V	C825	1-163-257-11	CERAMIC CHIP 180PF	5.00% 50V
C409	1-104-664-11	ELECT 47UF	20.00% 10V	C828	1-163-031-11	CERAMIC CHIP 0.01UF	50V
C410	1-163-035-00	CERAMIC CHIP 0.047UF	50V	C829	1-164-346-11	CERAMIC CHIP 1UF	16V
C412	1-126-960-11	ELECT 1UF	20.00% 50V	C832	1-164-346-11	CERAMIC CHIP 1UF	16V
C413	1-163-263-11	CERAMIC CHIP 330PF	5.00% 50V	C834	1-163-038-91	CERAMIC CHIP 0.1UF	25V
C414	1-104-664-11	ELECT 47UF	20.00% 10V	C835	1-163-038-91	CERAMIC CHIP 0.1UF	25V
				C837	1-104-664-11	ELECT 47UF	20.00% 10V
				C840	1-104-665-11	ELECT 100UF	20.00% 10V
				C841	1-126-964-11	ELECT 10UF	20.00% 50V
				C842	1-163-031-11	CERAMIC CHIP 0.01UF	50V
				C843	1-104-665-11	ELECT 100UF	20.00% 10V
				C844	1-126-964-11	ELECT 10UF	20.00% 50V
				C845	1-164-346-11	CERAMIC CHIP 1UF	16V
				C846	1-163-021-91	CERAMIC CHIP 0.01UF	10.00% 50V

The components identified by shading and mark  $\Delta$  are critical for safety. Replace only with part number specified.

Les composants identifiés par la marque  $\Delta$  sont critiques pour la sécurité. Ne les remplacer que par une pièce portant le numéro spécifié.

**MA10**

REF. NO.	PART NO.	DESCRIPTION	REMARK	REF. NO.	PART NO.	DESCRIPTION	REMARK
C847	1-163-038-11	CERAMIC CHIP 0.1UF	25V	C1803	1-163-259-91	CERAMIC CHIP 220PF	5.00% 50V (FR model)
C848	1-163-031-11	CERAMIC CHIP 0.01UF	50V	C1804	1-163-017-00	CERAMIC CHIP 0.0047UF	10.00% 50V (FR model)
C849	1-126-960-11	ELECT 1UF	20.00% 50V	C1805	1-163-017-00	CERAMIC CHIP 0.0047UF	10.00% 50V (FR model)
C850	1-163-031-11	CERAMIC CHIP 0.01UF	50V	C1806	1-164-004-11	CERAMIC CHIP 0.1UF	10.00% 25V (FR model)
C851	1-163-809-11	CERAMIC CHIP 0.047UF	10.00% 25V	C1807	1-163-021-91	CERAMIC CHIP 0.01UF	10.00% 50V (FR model)
C852	1-104-664-11	ELECT 47UF	20.00% 10V	C1808	1-163-021-91	CERAMIC CHIP 0.01UF	10.00% 50V (FR model)
C853	1-163-038-11	CERAMIC CHIP 0.1UF	25V	C1809	1-163-009-11	CERAMIC CHIP 0.001UF	10.00% 50V (FR model)
C854	1-126-960-11	ELECT 1UF	20.00% 50V	C1810	1-163-031-11	CERAMIC CHIP 0.01UF	50V (FR model)
C855	1-163-809-11	CERAMIC CHIP 0.047UF	10.00% 25V	C1811	1-163-031-11	CERAMIC CHIP 0.01UF	50V (FR model)
C856	1-126-960-11	ELECT 1UF	20.00% 50V	C1812	1-104-664-11	ELECT 47UF	20.00% 10V (FR model)
C857	1-163-037-11	CERAMIC CHIP 0.022UF	10.00% 50V	C1813	1-163-249-11	CERAMIC CHIP 82PF	5.00% 50V (FR model)
C858	1-126-960-11	ELECT 1UF	20.00% 50V	C1814	1-163-137-00	CERAMIC CHIP 680PF	5.00% 50V (FR model)
C859	1-163-038-11	CERAMIC CHIP 0.1UF	25V	C1815	1-163-021-91	CERAMIC CHIP 0.01UF	10.00% 50V (FR model)
C860	1-164-346-11	CERAMIC CHIP 1UF	16V	C1816	1-163-259-91	CERAMIC CHIP 220PF	5.00% 50V (FR model)
C861	1-163-031-11	CERAMIC CHIP 0.01UF	50V	C1817	1-164-004-11	CERAMIC CHIP 0.1UF	10.00% 25V (FR model)
C862	1-163-031-11	CERAMIC CHIP 0.01UF	50V	C1818	1-163-037-11	CERAMIC CHIP 0.022UF	10.00% 50V (FR model)
C863	1-104-664-11	ELECT 47UF	20.00% 10V	C1819	1-126-964-11	ELECT 10UF	20.00% 50V (FR model)
C864	1-163-016-00	CERAMIC CHIP 0.0039UF	10.00% 50V	C1820	1-126-959-11	ELECT 0.47UF	20.00% 50V (FR model)
C865	1-164-004-11	CERAMIC CHIP 0.1UF	10.00% 25V	C1821	1-126-960-11	ELECT 1UF	20.00% 50V (FR model)
C866	1-164-004-11	CERAMIC CHIP 0.1UF	10.00% 25V	C1822	1-163-021-91	CERAMIC CHIP 0.01UF	10.00% 50V (FR model)
C867	1-163-021-91	CERAMIC CHIP 0.01UF	10.00% 50V	C1824	1-126-961-11	ELECT 2.2UF	20.00% 50V (FR model)
C868	1-163-235-11	CERAMIC CHIP 22PF	5.00% 50V	C1826	1-163-251-11	CERAMIC CHIP 100PF	5.00% 50V (FR model)
C879	1-163-259-91	CERAMIC CHIP 220PF	5.00% 50V	<CONNECTOR>			
C901	1-163-009-11	CERAMIC CHIP 0.001UF	10.00% 50V	CN001	1-785-386-11	SOCKET, CONNECTOR 35P	
C902	1-164-346-11	CERAMIC CHIP 1UF	16V	CN002	*1-766-715-11	CONNECTOR, BOARD TO BOARD 10P	
C903	1-163-239-11	CERAMIC CHIP 33PF	5.00% 50V	CN251	*1-564-506-11	PLUG, CONNECTOR 3P	
C904	1-163-239-11	CERAMIC CHIP 33PF	5.00% 50V	CN401	1-695-328-11	SOCKET, CONNECTOR 5P	
C905	1-126-925-11	ELECT 470UF	20.00% 10V	CN403	1-779-723-11	CONNECTOR, BOARD TO BOARD 9P	
C906	1-164-004-11	CERAMIC CHIP 0.1UF	10.00% 25V	CN404	*1-766-716-11	CONNECTOR, BOARD TO BOARD 3P	
C907	1-164-346-11	CERAMIC CHIP 1UF	16V	CN701	*1-695-329-31	PIN, CONNECTOR (PC BOARD) 6P	
C908	1-126-925-11	ELECT 470UF	20.00% 10V	CN702	*1-560-892-00	PIN, CONNECTOR 4P	
C909	1-163-251-11	CERAMIC CHIP 100PF	5.00% 50V	CN1001	*1-564-506-11	PLUG, CONNECTOR 3P	
C910	1-164-346-11	CERAMIC CHIP 1UF	16V	CN1002	*1-569-926-11	SOCKET, CONNECTOR 7P	
C911	1-163-009-11	CERAMIC CHIP 0.001UF	10.00% 50V	CN1003	*1-564-510-11	PLUG, CONNECTOR 7P	
C912	1-164-004-11	CERAMIC CHIP 0.1UF	10.00% 25V	CN1004	1-784-038-11	CONNECTOR, BOARD TO BOARD 9P	
C913	1-164-004-11	CERAMIC CHIP 0.1UF	10.00% 25V	CN1701	*1-580-843-11	PIN, CONNECTOR (POWER)	
C1001	1-137-397-11	MYLAR 0.047UF	5.00% 100V	CN1702	*1-691-291-11	PIN, CONNECTOR (PC BOARD) 5P	
C1002	1-163-031-11	CERAMIC CHIP 0.01UF	50V	CN1703	1-695-915-11	TAB (CONTACT)	
C1003	1-163-021-91	CERAMIC CHIP 0.01UF	10.00% 50V	<DIODE>			
C1004	1-104-664-11	ELECT 47UF	20.00% 10V	D001	8-719-109-93	ZENER DIODE RD6.2ESB2	
C1006	1-163-021-91	CERAMIC CHIP 0.01UF	10.00% 50V	D002	8-719-921-54	ZENER DIODE MTZJ-6.2B	
C1007	1-104-664-11	ELECT 47UF	20.00% 10V	D004	8-719-921-54	ZENER DIODE MTZJ-6.2B	
C1008	1-126-963-11	ELECT 4.7UF	20.00% 50V	D005	8-719-921-40	ZENER DIODE MTZJ-4.7C	
C1009	1-126-964-11	ELECT 10UF	20.00% 50V	D006	8-719-921-44	ZENER DIODE MTZJ-5.1C	
C1010	1-137-150-11	MYLAR 0.01UF	5.00% 50V	D007	8-719-911-19	DIODE 1SS119-25	
C1011	1-163-011-11	CERAMIC CHIP 0.0015UF	10.00% 50V	D008	8-719-109-93	ZENER DIODE RD6.2ESB2	
C1012	1-163-011-11	CERAMIC CHIP 0.0015UF	10.00% 50V	D009	8-719-988-61	DIODE 1SS355TE-17	
C1013	1-164-346-11	CERAMIC CHIP 1UF	16V				
C1014	1-163-031-11	CERAMIC CHIP 0.01UF	50V				
C1015	1-126-960-11	ELECT 1UF	20.00% 50V				
C1016	1-104-664-11	ELECT 47UF	20.00% 16V				
C1017	1-126-963-11	ELECT 4.7UF	20.00% 50V				
C1019	1-104-664-11	ELECT 47UF	20.00% 10V				
C1020	1-126-960-11	ELECT 1UF	20.00% 50V				
C1021	1-126-964-11	ELECT 10UF	20.00% 50V				
C1101	1-163-009-11	CERAMIC CHIP 0.001UF	10.00% 50V				
C1102	1-163-009-11	CERAMIC CHIP 0.001UF	10.00% 50V				
C1103	1-163-033-91	CERAMIC CHIP 0.022UF	50V				
C1104	1-163-038-11	CERAMIC CHIP 0.1UF	25V				
C1105	1-163-021-91	CERAMIC CHIP 0.01UF	10.00% 50V				
C1106	1-163-021-91	CERAMIC CHIP 0.01UF	10.00% 50V				
C1107	1-163-019-00	CERAMIC CHIP 0.0068UF	10.00% 50V				
C1701	$\Delta$ 1-136-516-12	FILM 0.1UF	20.00% 300V				
C1702	$\Delta$ 1-136-516-12	FILM 0.1UF	20.00% 300V				
C1703	$\Delta$ 1-113-924-91	CERAMIC 0.0047UF	20.00% 250V				
C1801	1-163-021-91	CERAMIC CHIP 0.01UF	10.00% 50V (FR model)				
C1802	1-163-255-11	CERAMIC CHIP 150PF	5.00% 50V (FR model)				

# MA10

The components identified by shading and mark  $\Delta$  are critical for safety. Replace only with part number specified.

Les composants identifiés par la marque  $\Delta$  sont critiques pour la sécurité. Ne les remplacer que par une pièce portant le numéro spécifié.

REF. NO.	PART NO.	DESCRIPTION	REMARK	REF. NO.	PART NO.	DESCRIPTION	REMARK
D201	8-719-921-54	ZENER DIODE MTZJ-6.2B		JR111	1-216-295-11	SHORT	0
D202	8-719-921-54	ZENER DIODE MTZJ-6.2B		JR112	1-216-296-91	SHORT	0
D251	8-719-921-54	ZENER DIODE MTZJ-6.2B		JR113	1-216-296-91	SHORT	0
D252	8-719-921-54	ZENER DIODE MTZJ-6.2B		JR114	1-216-296-91	SHORT	0
D253	8-719-921-54	ZENER DIODE MTZJ-6.2B		JR115	1-216-296-91	SHORT	0
D254	8-719-921-54	ZENER DIODE MTZJ-6.2B		JR116	1-216-296-91	SHORT	0
D402	8-719-911-19	DIODE 1SS119-25		JR117	1-216-296-91	SHORT	0
D403	8-719-200-82	DIODE 11ES2		JR118	1-216-296-91	SHORT	0
D405	8-719-200-82	DIODE 11ES2		JR119	1-216-296-91	SHORT	0
D406	8-719-200-82	DIODE 11ES2		JR121	1-216-295-11	SHORT	0
D407	8-719-200-82	DIODE 11ES2		JR122	1-216-295-11	SHORT	0
D432	8-719-109-93	ZENER DIODE RD6.2ESB2		JR123	1-216-296-11	SHORT	0
D433	8-719-109-93	ZENER DIODE RD6.2ESB2		JR125	1-216-296-11	SHORT	0
D451	8-719-048-26	DIODE GL528V1		JR126	1-216-296-11	SHORT	0
D901	8-719-109-89	ZENER DIODE RD5.6ESB2		JR127	1-216-295-11	SHORT	0
D902	8-719-109-72	ZENER DIODE RD3.9ES-B2		JR136	1-216-295-11	SHORT	0
D903	8-719-914-43	DIODE DAN202K		JR137	1-216-295-11	SHORT	0
D904	8-719-109-89	ZENER DIODE RD5.6ESB2B		JR138	1-216-295-11	SHORT	0
D905	8-719-109-72	ZENER DIODE RD3.9ES-B2		JR140	1-216-295-11	SHORT	0
D1101	8-719-921-54	ZENER DIODE MTZJ-6.2B		JR142	1-216-295-11	SHORT	0
D1102	8-719-921-54	ZENER DIODE MTZJ-6.2B		JR143	1-216-295-11	SHORT	0
D1103	8-719-921-54	ZENER DIODE MTZJ-6.2B		JR144	1-216-295-11	SHORT	0
D1104	8-719-921-54	ZENER DIODE MTZJ-6.2B		JR145	1-216-295-11	SHORT	0
D1105	8-719-921-54	ZENER DIODE MTZJ-6.2B		JR146	1-216-295-11	SHORT	0
D1106	8-719-109-93	ZENER DIODE RD6.2ESB2		JR147	1-216-295-11	SHORT	0
D1107	8-719-109-93	ZENER DIODE RD6.2ESB2		JR148	1-216-295-11	SHORT	0
D1108	8-719-109-93	ZENER DIODE RD6.2ESB2		JR149	1-216-295-11	SHORT	0
D1109	8-719-109-93	ZENER DIODE RD6.2ESB2		JR150	1-216-296-91	SHORT	0
D1110	8-719-921-54	ZENER DIODE MTZJ-6.2B		JR151	1-216-296-91	SHORT	0
		<FUSE>		JR152	1-216-296-91	SHORT	0
F1701	$\Delta$ 1-576-232-21	FUSE (H.B.C.) (5A/250V)		JR153	1-216-296-91	SHORT	0
FH1701	* 1-533-725-11	HOLDER, FUSE; F1701		JR154	1-216-296-91	SHORT	0
		<IC>		JR155	1-216-296-91	SHORT	0
IC001	8-752-917-77	IC CXP85452-233Q-TL		JR156	1-216-296-91	SHORT	0
IC002	8-759-527-77	IC M24C16-MN6T		JR157	1-216-296-91	SHORT	0
IC003	8-759-510-43	IC PST572C		JR158	1-216-296-91	SHORT	0
IC005	8-759-484-61	IC SDA5650X-GEG (except ESP model)		JR159	1-216-296-91	SHORT	0
IC201	8-759-442-73	IC TDA7494		JR160	1-216-296-91	SHORT	0
		<COIL>		JR163	1-216-296-91	SHORT	0
IC252	8-759-530-93	IC S-3510ACFJA-TB		JR164	1-216-296-91	SHORT	0
IC401	8-759-353-59	IC LB1643		L001	1-469-013-31	INDUCTOR 18UH	
IC402	8-752-918-13	IC CXP87852-063Q-TL		L002	1-410-509-11	INDUCTOR 10UH	
IC403	8-759-702-02	IC NJM062M		L003	1-414-856-11	INDUCTOR 10UH	(except ESP model)
IC404	8-759-510-73	IC BA10393F-E2		L004	1-414-856-11	INDUCTOR 10UH	
IC405	8-759-438-83	IC BA6305F-E2		L201	1-414-856-11	INDUCTOR 10UH	
IC701	8-759-357-84	IC HA118295NT		L202	1-414-856-11	INDUCTOR 10UH	
IC801	8-759-439-50	IC LC89977M-TE-L		L402	1-410-509-11	INDUCTOR 10UH	
IC802	8-759-479-25	IC LA71514M-MPB		L403	1-414-856-11	INDUCTOR 10UH	
IC901	8-759-689-43	IC SAA5563PS/M3/0189		L404	1-216-295-11	SHORT	0
IC902	8-759-591-02	IC L78L33ABZ-AP		L431	1-410-509-11	INDUCTOR 10UH	
IC1001	8-759-499-30	IC BA7755AF-E2		L703	1-408-615-31	INDUCTOR 100UH	
IC1101	8-742-014-21	HYB IC SBX1981-51(21)		L704	1-408-615-31	INDUCTOR 100UH	
IC1801	8-759-438-17	IC LA7337 (FR model)		L801	1-410-439-11	INDUCTOR 470UH	
		<JACK>		L803	1-408-977-21	INDUCTOR 39UH	
J1101	1-779-205-11	JACK, PIN 2P (VIDEO/AUDIO IN)		L804	1-408-977-21	INDUCTOR 39UH	
J1102	1-568-267-21	JACK (HEADPHONE)		L808	1-414-184-41	INDUCTOR 15UH	
		<CHIP CONDUCTOR>		L809	1-408-615-31	INDUCTOR 100UH	
JR001	1-216-295-11	SHORT	0	L811	1-414-185-41	INDUCTOR 22UH	
JR101	1-216-295-11	SHORT	0	L812	1-414-185-41	INDUCTOR 22UH	
JR103	1-216-295-11	SHORT	0	L813	1-414-187-11	INDUCTOR 47UH	
JR109	1-216-295-11	SHORT	0	L815	1-414-190-31	INDUCTOR 120UH	
JR110	1-216-295-11	SHORT	0	L901	1-414-856-11	INDUCTOR 10UH	
				L902	1-414-856-11	INDUCTOR 10UH	
				L903	1-414-856-11	INDUCTOR 10UH	
				L1001	1-408-615-31	INDUCTOR 100UH	
				L1003	1-420-872-00	COIL, AIR CORE	
				L1004	1-414-187-11	INDUCTOR 47UH	



The components identified by shading and mark  $\triangle$  are critical for safety. Replace only with part number specified.

Les composants identifiés par la marque  $\triangle$  sont critiques pour la sécurité. Ne les remplacer que par une pièce portant le numéro spécifié.

**MA10**

REF. NO.	PART NO.	DESCRIPTION	REMARK	REF. NO.	PART NO.	DESCRIPTION	REMARK
L1102	1-408-982-11	INDUCTOR 100UH		R016	1-216-049-11	RES-CHIP 1K	5% 1/10W
L1103	1-414-177-11	INDUCTOR 1UH		R017	1-216-025-11	RES-CHIP 100	5% 1/10W
L1104	1-414-183-41	INDUCTOR 10UH		R018	1-216-041-00	RES-CHIP 470	5% 1/10W
L1801	1-408-968-21	INDUCTOR 6.8UH	(FR model)	R020	1-216-025-11	RES-CHIP 100	5% 1/10W
L1802	1-408-974-21	INDUCTOR 22UH	(FR model)	R022	1-216-065-91	RES-CHIP 4.7K	5% 1/10W
L1803	*1-408-980-21	INDUCTOR 68UH	(FR model)	R025	1-216-073-00	RES-CHIP 10K	5% 1/10W
L1804	1-408-975-21	INDUCTOR 27UH	(FR model)	R026	1-216-049-11	RES-CHIP 1K	5% 1/10W
L1806	1-408-978-21	INDUCTOR 47UH	(FR model)	R027	1-216-079-00	RES-CHIP 18K	5% 1/10W
		<PHOTO COUPLER>		R029	1-216-049-11	RES-CHIP 1K	5% 1/10W
PH451	8-749-013-23	PHOTO INTERRUPTER GP3S120		R030	1-216-033-00	RES-CHIP 220	5% 1/10W
PH452	8-749-013-23	PHOTO INTERRUPTER GP3S120		R036	1-216-025-11	RES-CHIP 100	5% 1/10W
		<IC LINK>		R037	1-216-025-11	RES-CHIP 100	5% 1/10W
PS201	$\triangle$ 1-532-605-91	LINK, IC (0.4A/150V)		R038	1-216-025-11	RES-CHIP 100	5% 1/10W
		<TRANSISTOR>		R039	1-216-025-11	RES-CHIP 100	5% 1/10W
Q003	8-729-421-22	TRANSISTOR UN2211		R040	1-216-073-00	RES-CHIP 10K	5% 1/10W
Q005	8-729-421-19	TRANSISTOR UN2213		R041	1-216-065-91	RES-CHIP 4.7K	5% 1/10W
Q006	8-729-421-19	TRANSISTOR UN2213		R042	1-216-065-91	RES-CHIP 4.7K	5% 1/10W
Q008	8-729-421-19	TRANSISTOR UN2213		R043	1-216-065-91	RES-CHIP 4.7K	5% 1/10W
Q009	8-729-120-28	TRANSISTOR 2SC1623-L5L6		R044	1-216-065-91	RES-CHIP 4.7K	5% 1/10W
Q201	8-729-422-27	TRANSISTOR 2SD601A-Q		R045	1-216-295-11	SHORT 0	
Q402	8-729-424-18	TRANSISTOR UN2113		R046	1-216-025-11	RES-CHIP 100	5% 1/10W
Q451	8-729-281-53	TRANSISTOR 2SC1815-GR		R047	1-216-025-11	RES-CHIP 100	5% 1/10W
Q452	8-729-042-88	TRANSISTOR RPT-37PB3F		R048	1-216-045-00	RES-CHIP 680	5% 1/10W
Q453	8-729-042-88	TRANSISTOR RPT-37PB3F		R049	1-216-065-91	RES-CHIP 4.7K	5% 1/10W
Q701	8-729-422-27	TRANSISTOR 2SD601A-Q		R050	1-216-025-11	RES-CHIP 100	5% 1/10W (except ESP model)
Q801	8-729-422-27	TRANSISTOR 2SD601A-Q		R051	1-216-065-91	RES-CHIP 4.7K	5% 1/10W
Q803	8-729-422-27	TRANSISTOR 2SD601A-Q		R052	1-216-073-00	RES-CHIP 10K	5% 1/10W
Q808	8-729-422-27	TRANSISTOR 2SD601A-Q		R053	1-216-057-00	RES-CHIP 2.2K	5% 1/10W
Q809	8-729-421-19	TRANSISTOR UN2213		R054	1-216-049-11	RES-CHIP 1K	5% 1/10W
Q812	8-729-422-27	TRANSISTOR 2SD601A-Q		R055	1-216-033-00	RES-CHIP 220	5% 1/10W
Q815	8-729-422-27	TRANSISTOR 2SD601A-Q		R056	1-216-033-00	RES-CHIP 220	5% 1/10W
Q821	8-729-422-27	TRANSISTOR 2SD601A-Q		R057	1-216-049-11	RES-CHIP 1K	5% 1/10W
Q822	8-729-422-27	TRANSISTOR 2SD601A-Q		R058	1-216-039-00	RES-CHIP 390	5% 1/10W
Q824	8-729-216-22	TRANSISTOR 2SA1162-G		R059	1-216-049-11	RES-CHIP 1K	5% 1/10W
Q825	8-729-422-27	TRANSISTOR 2SD601A-Q		R060	1-216-049-11	RES-CHIP 1K	5% 1/10W
Q830	8-729-216-22	TRANSISTOR 2SA1162-G		R064	1-216-049-11	RES-CHIP 1K	5% 1/10W
Q901	8-729-216-22	TRANSISTOR 2SA1162-G		R065	1-216-049-11	RES-CHIP 1K	5% 1/10W
Q902	8-729-422-27	TRANSISTOR 2SD601A-Q		R067	1-216-025-11	RES-CHIP 100	5% 1/10W
Q903	8-729-422-27	TRANSISTOR 2SD601A-Q		R068	1-216-025-11	RES-CHIP 100	5% 1/10W
Q904	8-729-422-27	TRANSISTOR 2SD601A-Q		R075	1-216-049-11	RES-CHIP 1K	5% 1/10W
Q1001	8-729-802-91	TRANSISTOR 2SD879		R076	1-216-065-91	RES-CHIP 4.7K	5% 1/10W
Q1002	8-729-422-27	TRANSISTOR 2SD601A-Q		R077	1-216-089-11	RES-CHIP 47K	5% 1/10W
Q1801	8-729-216-22	TRANSISTOR 2SA1162-G	(FR model)	R078	1-216-073-00	RES-CHIP 10K	5% 1/10W
Q1802	8-729-424-56	TRANSISTOR UN211L	(FR model)	R083	1-216-069-00	RES-CHIP 6.8K	5% 1/10W (except ESP model)
Q1804	8-729-230-49	TRANSISTOR 2SC2712-YG	(FR model)	R084	1-216-033-00	RES-CHIP 220	5% 1/10W
Q1805	8-729-230-49	TRANSISTOR 2SC2712-YG	(FR model)	R085	1-216-049-11	RES-CHIP 1K	5% 1/10W
Q1806	8-729-230-49	TRANSISTOR 2SC2712-YG	(FR model)	R087	1-216-097-11	RES-CHIP 100K	5% 1/10W (except ESP model)
Q1807	8-729-421-19	TRANSISTOR UN2213	(FR model)	R088	1-216-123-11	RES-CHIP 1.2M	5% 1/10W (except ESP model)
Q1808	8-729-424-08	TRANSISTOR UN2111	(FR model)	R089	1-216-025-11	RES-CHIP 100	5% 1/10W (except ESP model)
		<RESISTOR>		R090	1-216-069-00	RES-CHIP 6.8K	5% 1/10W (except ESP model)
R001	1-216-049-11	RES-CHIP 1K	5% 1/10W	R091	1-216-123-11	RES-CHIP 1.2M	5% 1/10W (except ESP model)
R004	1-216-049-11	RES-CHIP 1K	5% 1/10W	R092	1-216-121-11	RES-CHIP 1M	5% 1/10W (except ESP model)
R005	1-216-089-11	RES-CHIP 47K	5% 1/10W	R093	1-216-057-00	RES-CHIP 2.2K	5% 1/10W (except ESP model)
R006	1-216-041-00	RES-CHIP 470	5% 1/10W	R095	1-216-295-11	SHORT 0	5% 1/10W (except ESP model)
R007	1-249-421-11	CARBON 2.2K	5% 1/4W	R096	1-216-069-00	RES-CHIP 6.8K	5% 1/10W
R009	1-216-049-11	RES-CHIP 1K	5% 1/10W	R097	1-216-073-00	RES-CHIP 10K	5% 1/10W
R011	1-216-025-11	RES-CHIP 100	5% 1/10W (except ESP model)	R098	1-216-025-11	RES-CHIP 100	5% 1/10W
R012	1-216-025-11	RES-CHIP 100	5% 1/10W	R100	1-216-073-00	RES-CHIP 10K	5% 1/10W
R013	1-216-049-11	RES-CHIP 1K	5% 1/10W	R101	1-216-073-00	RES-CHIP 10K	5% 1/10W
R014	1-216-049-11	RES-CHIP 1K	5% 1/10W	R204	1-247-807-31	CARBON 100	5% 1/4W
R015	1-216-049-11	RES-CHIP 1K	5% 1/10W	R205	1-216-049-11	RES-CHIP 1K	5% 1/10W
				R206	1-216-109-00	RES-CHIP 330K	5% 1/10W

# MA10

REF. NO.	PART NO.	DESCRIPTION	REMARK	REF. NO.	PART NO.	DESCRIPTION	REMARK
R210	1-216-057-00	RES-CHIP	2.2K 5% 1/10W	R470	1-216-041-00	RES-CHIP	470 5% 1/10W
R211	1-216-073-00	RES-CHIP	10K 5% 1/10W	R471	1-216-041-00	RES-CHIP	470 5% 1/10W
R212	1-216-049-11	RES-CHIP	1K 5% 1/10W	R472	1-216-041-00	RES-CHIP	470 5% 1/10W
R216	1-249-385-11	CARBON	2.2 5% 1/4W	R473	1-216-041-00	RES-CHIP	470 5% 1/10W
R218	1-216-105-91	RES-CHIP	220K 5% 1/10W	R474	1-216-073-00	RES-CHIP	10K 5% 1/10W
R219	1-216-033-00	RES-CHIP	220 5% 1/10W	R476	1-216-049-11	RES-CHIP	1K 5% 1/10W
R220	1-216-065-91	RES-CHIP	4.7K 5% 1/10W	R477	1-216-049-11	RES-CHIP	1K 5% 1/10W
R263	1-216-025-11	RES-CHIP	100 5% 1/10W	R478	1-216-049-11	RES-CHIP	1K 5% 1/10W
R264	1-216-025-11	RES-CHIP	100 5% 1/10W	R479	1-216-065-91	RES-CHIP	4.7K 5% 1/10W
R265	1-216-295-11	SHORT	0	R480	1-216-049-11	RES-CHIP	1K 5% 1/10W
R401	1-216-073-00	RES-CHIP	10K 5% 1/10W	R481	1-216-049-11	RES-CHIP	1K 5% 1/10W
R402	1-216-073-00	RES-CHIP	10K 5% 1/10W	R484	1-216-049-11	RES-CHIP	1K 5% 1/10W
R403	1-216-049-11	RES-CHIP	1K 5% 1/10W	R487	1-216-045-00	RES-CHIP	680 5% 1/10W
R404	1-216-073-00	RES-CHIP	10K 5% 1/10W	R701	1-216-025-11	RES-CHIP	100 5% 1/10W
R405	1-216-073-00	RES-CHIP	10K 5% 1/10W	R702	1-216-045-00	RES-CHIP	680 5% 1/10W
R406	1-216-053-00	RES-CHIP	1.5K 5% 1/10W	R705	1-216-055-00	RES-CHIP	1.8K 5% 1/10W
R407	1-216-053-00	RES-CHIP	1.5K 5% 1/10W	R706	1-216-081-00	RES-CHIP	22K 5% 1/10W
R408	1-216-073-00	RES-CHIP	10K 5% 1/10W	R707	1-216-073-00	RES-CHIP	10K 5% 1/10W
R409	1-216-073-00	RES-CHIP	10K 5% 1/10W	R708	1-216-049-11	RES-CHIP	1K 5% 1/10W
R410	1-216-049-11	RES-CHIP	1K 5% 1/10W	R709	1-216-061-00	RES-CHIP	3.3K 5% 1/10W
R411	1-216-065-91	RES-CHIP	4.7K 5% 1/10W	R710	1-216-049-11	RES-CHIP	1K 5% 1/10W
R412	1-216-057-00	RES-CHIP	2.2K 5% 1/10W	R711	1-216-049-11	RES-CHIP	1K 5% 1/10W
R414	1-216-097-11	RES-CHIP	100K 5% 1/10W	R712	1-216-049-11	RES-CHIP	1K 5% 1/10W
R415	1-216-097-11	RES-CHIP	100K 5% 1/10W	R801	1-216-041-00	RES-CHIP	470 5% 1/10W
R416	1-216-105-91	RES-CHIP	220K 5% 1/10W	R803	1-216-057-00	RES-CHIP	2.2K 5% 1/10W
R417	1-216-111-00	RES-CHIP	390K 5% 1/10W	R804	1-216-057-00	RES-CHIP	2.2K 5% 1/10W
R418	1-216-097-11	RES-CHIP	100K 5% 1/10W	R810	1-216-041-00	RES-CHIP	470 5% 1/10W
R419	1-216-097-11	RES-CHIP	100K 5% 1/10W	R811	1-216-041-00	RES-CHIP	470 5% 1/10W
R420	1-216-117-00	RES-CHIP	680K 5% 1/10W	R813	1-216-047-91	RES-CHIP	820 5% 1/10W
R421	1-216-079-00	RES-CHIP	18K 5% 1/10W	R814	1-216-041-00	RES-CHIP	470 5% 1/10W
R422	1-216-689-11	RES-CHIP	39K 5% 1/10W	R815	1-249-413-11	CARBON	470 5% 1/4W
R423	1-216-049-11	RES-CHIP	1K 5% 1/10W	R819	1-216-081-00	RES-CHIP	22K 5% 1/10W
R424	1-216-675-91	METAL CHIP	10K 0.50% 1/10W	R820	1-216-081-00	RES-CHIP	22K 5% 1/10W
R425	1-216-057-00	RES-CHIP	2.2K 5% 1/10W	R823	1-216-049-11	RES-CHIP	1K 5% 1/10W
R426	1-216-057-00	RES-CHIP	2.2K 5% 1/10W	R824	1-216-049-11	RES-CHIP	1K 5% 1/10W
R427	1-216-103-00	RES-CHIP	180K 5% 1/10W	R827	1-216-025-11	RES-CHIP	100 5% 1/10W
R428	1-216-675-91	METAL CHIP	10K 0.50% 1/10W	R829	1-216-065-91	RES-CHIP	4.7K 5% 1/10W
R429	1-216-065-91	RES-CHIP	4.7K 5% 1/10W	R831	1-216-295-11	SHORT	0
R430	1-216-037-00	RES-CHIP	330 5% 1/10W	R835	1-216-041-00	RES-CHIP	470 5% 1/10W
R432	1-216-073-00	RES-CHIP	10K 5% 1/10W	R837	1-216-073-00	RES-CHIP	10K 5% 1/10W
R435	1-216-049-11	RES-CHIP	1K 5% 1/10W	R838	1-216-065-91	RES-CHIP	4.7K 5% 1/10W
R436	1-216-043-11	RES-CHIP	560 5% 1/10W	R839	1-216-055-00	RES-CHIP	1.8K 5% 1/10W
R437	1-216-065-91	RES-CHIP	4.7K 5% 1/10W	R840	1-216-025-11	RES-CHIP	100 5% 1/10W
R438	1-216-295-11	SHORT	0	R841	1-216-062-00	RES-CHIP	3.6K 5% 1/10W
R439	1-216-089-11	RES-CHIP	47K 5% 1/10W	R843	1-216-041-00	RES-CHIP	470 5% 1/10W
R440	1-216-089-11	RES-CHIP	47K 5% 1/10W	R845	1-216-057-00	RES-CHIP	2.2K 5% 1/10W
R441	1-216-089-11	RES-CHIP	47K 5% 1/10W	R847	1-216-295-11	SHORT	0
R442	1-216-089-11	RES-CHIP	47K 5% 1/10W	R848	1-216-065-91	RES-CHIP	4.7K 5% 1/10W
R443	1-216-049-11	RES-CHIP	1K 5% 1/10W	R849	1-216-295-11	SHORT	0
R444	1-216-295-11	SHORT	0	R850	1-216-065-91	RES-CHIP	4.7K 5% 1/10W
R445	1-216-089-11	RES-CHIP	47K 5% 1/10W	R852	1-216-053-00	RES-CHIP	1.5K 5% 1/10W
R446	1-216-075-00	RES-CHIP	12K 5% 1/10W	R856	1-216-071-00	RES-CHIP	8.2K 5% 1/10W
R447	1-216-081-00	RES-CHIP	22K 5% 1/10W	R857	1-216-049-11	RES-CHIP	1K 5% 1/10W
R448	1-216-075-00	RES-CHIP	12K 5% 1/10W	R858	1-216-049-11	RES-CHIP	1K 5% 1/10W
R449	1-216-081-00	RES-CHIP	22K 5% 1/10W	R859	1-216-055-00	RES-CHIP	1.8K 5% 1/10W
R450	1-216-077-91	RES-CHIP	15K 5% 1/10W	R860	1-216-061-00	RES-CHIP	3.3K 5% 1/10W
R451	1-216-057-00	RES-CHIP	2.2K 5% 1/10W	R861	1-216-089-11	RES-CHIP	47K 5% 1/10W
R452	1-249-400-11	CARBON	39 5% 1/4W	R862	1-216-045-00	RES-CHIP	680 5% 1/10W
R453	1-249-400-11	CARBON	39 5% 1/4W	R867	1-216-057-00	RES-CHIP	2.2K 5% 1/10W
R454	1-249-406-11	CARBON	120 5% 1/4W	R869	1-216-049-11	RES-CHIP	1K 5% 1/10W
R455	1-216-089-11	RES-CHIP	47K 5% 1/10W	R870	1-216-057-00	RES-CHIP	2.2K 5% 1/10W
R456	1-216-089-11	RES-CHIP	47K 5% 1/10W	R871	1-216-057-00	RES-CHIP	2.2K 5% 1/10W
R457	1-216-085-00	RES-CHIP	33K 5% 1/10W	R872	1-216-057-00	RES-CHIP	2.2K 5% 1/10W
R458	1-216-085-00	RES-CHIP	33K 5% 1/10W	R873	1-216-049-11	RES-CHIP	1K 5% 1/10W
R459	1-216-085-00	RES-CHIP	33K 5% 1/10W	R875	1-216-295-11	SHORT	0
R460	1-216-057-00	RES-CHIP	2.2K 5% 1/10W	R881	1-216-089-11	RES-CHIP	47K 5% 1/10W
R461	1-216-085-00	RES-CHIP	33K 5% 1/10W	R882	1-216-689-11	RES-CHIP	39K 5% 1/10W
R465	1-216-045-00	RES-CHIP	680 5% 1/10W	R883	1-216-049-11	RES-CHIP	1K 5% 1/10W
R468	1-216-089-11	RES-CHIP	47K 5% 1/10W	R885	1-216-049-11	RES-CHIP	1K 5% 1/10W

The components identified by shading and mark  $\triangle$  are critical for safety. Replace only with part number specified.

Les composants identifiés par la marque  $\triangle$  sont critiques pour la sécurité. Ne les remplacer que par une pièce portant le numéro spécifié.

# MA10

REF. NO.	PART NO.	DESCRIPTION	REMARK	REF. NO.	PART NO.	DESCRIPTION	REMARK
R901	1-216-065-91	RES-CHIP	4.7K 5%	R1803	1-216-072-00	RES-CHIP	9.1K 5% (FR model)
R902	1-216-025-11	RES-CHIP	100 5%	R1804	1-216-080-00	RES-CHIP	20K 5% (FR model)
R903	1-216-025-11	RES-CHIP	100 5%	R1805	1-216-083-00	RES-CHIP	27K 5% (FR model)
R904	1-216-025-11	RES-CHIP	100 5%	R1806	1-216-071-00	RES-CHIP	8.2K 5% (FR model)
R905	1-216-025-11	RES-CHIP	100 5%	R1807	1-216-049-11	RES-CHIP	1K 5% (FR model)
R906	1-216-065-91	RES-CHIP	4.7K 5%	R1808	1-216-689-11	RES-CHIP	39K 5% (FR model)
R907	1-216-089-11	RES-CHIP	47K 5%	R1809	1-216-083-00	RES-CHIP	27K 5% (FR model)
R908	1-216-025-11	RES-CHIP	100 5%	R1810	1-216-041-00	RES-CHIP	470 5% (FR model)
R909	1-216-041-00	RES-CHIP	470 5%	R1811	1-216-067-00	RES-CHIP	5.6K 5% (FR model)
R910	1-216-037-00	RES-CHIP	330 5%	R1812	1-216-081-00	RES-CHIP	22K 5% (FR model)
R911	1-216-065-91	RES-CHIP	4.7K 5%	R1813	1-216-077-91	RES-CHIP	15K 5% (FR model)
R912	1-216-082-00	RES-CHIP	24K 5%	R1814	1-216-073-00	RES-CHIP	10K 5% (FR model)
R913	1-216-025-11	RES-CHIP	100 5%	R1815	1-216-089-11	RES-CHIP	47K 5% (FR model)
R914	1-216-025-11	RES-CHIP	100 5%	R1816	1-216-059-00	RES-CHIP	2.7K 5% (FR model)
R915	1-216-029-00	RES-CHIP	150 5%	R1817	1-216-089-11	RES-CHIP	47K 5% (FR model)
R916	1-216-029-00	RES-CHIP	150 5%	R1818	1-216-089-11	RES-CHIP	47K 5% (FR model)
R917	1-216-025-11	RES-CHIP	100 5%	R1819	1-216-073-00	RES-CHIP	10K 5% (FR model)
R918	1-247-807-31	CARBON	100 5%	R1820	1-216-295-11	SHORT	0 (FR model)
R919	1-216-029-00	RES-CHIP	150 5%	R1821	1-216-083-00	RES-CHIP	27K 5% (FR model)
R920	1-216-041-00	RES-CHIP	470 5%	R1822	1-216-689-11	RES-CHIP	39K 5% (FR model)
R921	1-216-049-11	RES-CHIP	1K 5%	R1823	1-216-073-00	RES-CHIP	10K 5% (FR model)
R922	1-216-061-00	RES-CHIP	3.3K 5%	R1831	1-216-295-11	SHORT	0 (FR model)
R924	1-216-073-00	RES-CHIP	10K 5%	<SWITCH>			
R925	1-216-073-00	RES-CHIP	10K 5%	S401	1-771-155-11	SWITCH, ROTARY (MODE SW)	
R927	1-216-049-11	RES-CHIP	1K 5%	S451	1-762-108-11	SWITCH, PUSH (1 KEY) (REC PRF)	
R928	1-216-097-11	RES-CHIP	100K 5%	S1101	1-571-532-21	SWITCH, TACTIL (TIMER REC)	
R929	1-216-065-91	RES-CHIP	4.7K 5%	S1102	1-570-577-11	SWITCH, PUSH (STOP/REC)	
R930	1-216-073-00	RES-CHIP	10K 5%	S1103	1-570-577-11	SWITCH, PUSH (REW/VOL -)	
R1002	1-249-408-11	CARBON	180 5%	S1104	1-570-577-11	SWITCH, PUSH (PLAY/VOL +)	
R1003	1-249-381-11	CARBON	1 5%	S1105	1-571-532-21	SWITCH, TACTIL (CH -)	
R1004	1-216-063-91	RES-CHIP	3.9K 5%	S1106	1-570-577-11	SWITCH, PUSH (FWD/CH +)	
R1005	1-249-401-11	CARBON	47 5%	S1107	1-570-577-11	SWITCH, PUSH (PAUSE)	
R1006	1-216-075-00	RES-CHIP	12K 5%	S1108	1-571-532-21	SWITCH, TACTIL (POWER)	
R1007	1-216-079-00	RES-CHIP	18K 5%	S1109	1-571-532-21	SWITCH, TACTIL (INPUT SELECT)	
R1008	1-216-035-00	RES-CHIP	270 5%	S1701	$\triangle$ 1-571-433-31	SWITCH, PUSH (AC POWER)	
R1010	1-216-109-00	RES-CHIP	330K 5%	<TRANSFORMER>			
R1011	1-216-073-00	RES-CHIP	10K 5%	T1001	1-431-097-11	TRANSFORMER, BIAS OSCILLATION	
R1012	1-216-047-91	RES-CHIP	820 5%	T1701	$\triangle$ 1-427-962-11	TRANSFORMER, LINE FILTER	
R1013	1-216-079-00	RES-CHIP	18K 5%	<VARISTOR>			
R1014	1-216-051-00	RES-CHIP	1.2K 5%	VDR601	$\triangle$ 1-803-830-31	VARISTOR (ERZV14D621)	
R1015	1-216-069-00	RES-CHIP	6.8K 5%	<CRYSTAL>			
R1017	1-249-426-11	CARBON	5.6K 5%	X001	1-767-755-11	VIBRATOR, CRYSTAL	
R1018	1-216-061-00	RES-CHIP	3.3K 5%	X251	1-579-463-11	VIBRATOR, CRYSTAL	
R1019	1-216-073-00	RES-CHIP	10K 5%	X430	1-760-494-11	VIBRATOR, CRYSTAL	
R1020	1-216-025-11	RES-CHIP	100 5%				
R1023	1-216-067-00	RES-CHIP	5.6K 5%				
R1024	1-216-093-91	RES-CHIP	68K 5%				
R1025	1-216-129-00	RES-CHIP	2.2M 5%				
R1101	1-216-045-00	RES-CHIP	680 5%				
R1102	1-216-051-00	RES-CHIP	1.2K 5%				
R1103	1-216-045-00	RES-CHIP	680 5%				
R1104	1-216-055-00	RES-CHIP	1.8K 5%				
R1106	1-216-022-00	RES-CHIP	75 5%				
R1108	1-216-061-00	RES-CHIP	3.3K 5%				
R1109	1-216-079-00	RES-CHIP	18K 5%				
R1110	1-216-067-00	RES-CHIP	5.6K 5%				
R1111	1-216-067-00	RES-CHIP	5.6K 5%				
R1112	1-216-047-91	RES-CHIP	820 5%				
R1113	1-216-061-00	RES-CHIP	3.3K 5%				
R1115	1-216-055-00	RES-CHIP	1.8K 5%				
R1116	1-216-047-91	RES-CHIP	820 5%				
R1119	1-216-295-11	SHORT	0				
R1128	1-216-037-00	RES-CHIP	330 5%				
R1129	1-216-037-00	RES-CHIP	330 5%				
R1136	1-216-051-00	RES-CHIP	1.2K 5%				
R1701	$\triangle$ 1-260-135-91	CARBON	1M 5%				
R1801	1-216-089-11	RES-CHIP	47K 5%				
R1802	1-216-071-00	RES-CHIP	8.2K 5%				

**KV-14FV1B/FV1D/FV1E/FV1U**  
 RM-816 RM-814 RM-814 RM-815  
**KV-21FV1B/FV1D/FV1E/FV1U**  
 RM-816 RM-814 RM-814 RM-815

**MA10 H10**

The components identified by shading and mark  $\Delta$  are critical for safety. Replace only with part number specified.

Les composants identifiés par la marque  $\Delta$  sont critiques pour la sécurité. Ne les remplacer que par une pièce portant le numéro spécifié.

REF. NO.	PART NO.	DESCRIPTION	REMARK
X801	1-579-608-11	VIBRATOR, CRYSTAL	
X901	1-578-774-11	VIBRATOR, CRYSTAL	
*****			
	* A-1646-216-AH10 BOARD, COMPLETE *****		
		<CONNECTOR>	
CN1301	1-766-719-11	CONNECTOR, BOARD TO BOARD 10P	
		<DIODE>	
D1301	8-719-053-43	DIODE SLR-325VCT31 (REC)	
D1302	8-719-053-43	DIODE SLR-325VCT31 (TIMER REC)	
D1303	8-719-061-96	DIODE SLR-325DCT31 (DIAL TIMER)	
D1304	8-719-053-43	DIODE SLR-325VCT31 (STBY)	
D1305	8-719-061-96	DIODE SLR-325DCT31 (DIAL TIMER)	
D1306	8-719-061-96	DIODE SLR-325DCT31 (DIAL TIMER)	
		<CHIP CONDUCTOR>	
JR165	1-216-296-91	SHORT 0	
		<TRANSISTOR>	
Q1301	8-729-902-99	TRANSISTOR DTC114TK	
		<RESISTOR>	
R1301	1-249-403-11	CARBON 68 5% 1/4W	
R1302	1-249-406-11	CARBON 120 5% 1/4W	
R1307	1-216-073-00	RES-CHIP 10K 5% 1/10W	
R1308	1-216-073-00	RES-CHIP 10K 5% 1/10W	
		<SWITCH>	
S1301	1-762-196-21	SWITCH, TACT (EJECT)	
S1302	1-418-156-11	ENCODER, ROTARYRY (DIAL TIMER)	

\*\*\*\*\*

REF. NO.	PART NO.	DESCRIPTION	REMARK
MISCELLANEOUS *****			
	$\Delta$ 1-251-317-32	CAP ASSY, HIGH VOLTAGE (14inch model)	
	$\Delta$ 1-416-864-12	COIL, VM	
	$\Delta$ 1-419-548-11	COIL, DEGAUSSING (14inch model)	
	1-419-494-11	COIL, CHOKE 56.0 mH (21inch model)	
	$\Delta$ 1-419-772-11	COIL, DEGAUSSING (21inch model)	
	1-452-032-00	MAGNET, DISC ; 10mmø	
	1-452-094-00	MAGNET, ROTATABLE DISC ; 15mmø	
	$\Delta$ 1-452-728-61	COIL, NA ROTATION (RT-154) (21inch model)	
	1-529-474-11	SPEAKER (5CM) (14inch model)	
	1-529-710-11	SPEAKER (5X9CM) (21inch model)	
	$\Delta$ 1-765-286-11	CORD, POWER (FR/AEP/ESP model)	
	$\Delta$ 1-776-860-12	POWER CORD, FILTER (UK) (UK model)	
	1-900-905-56	CONNECTOR ASSY 7P	
	1-900-905-60	CONNECTOR ASSY 5P	
	1-900-905-61	CONNECTOR ASSY 35P	
	1-900-905-74	CONNECTOR ASSY, MICRO 5P (21inch model)	
	$\Delta$ 8-451-401-21	DEFLECTION YOKE (Y14RSA-L) (14inch model)	
	$\Delta$ 8-451-505-41	DEFLECTION YOKE (Y21RSA-L) (21inch model)	
V901	$\Delta$ 8-738-570-05	PICTURE TUBE (A34LRG70X) (14inch model)	
V901	$\Delta$ 8-738-836-05	PICTURE TUBE (A51LPT60X) (21inch model)	

\*\*\*\*\*

ACCESSORIES AND PACKING MATERIALS  
\*\*\*\*\*

1-501-615-31	ANTENNA, LOOP (14inch UK model)
* 4-039-905-02	BAG, PROTECTION (14inch model)
* 4-395-957-01	BAG, PROTECTION (21inch model)
* 4-205-654-01	CUSHION LOWER ASSY (14inch model)
* 4-205-655-01	CUSHION UPPER ASSY (14inch model)
4-205-660-01	INDIVIDUAL CARTON (14inch model)
4-205-687-11	INSTRUCTION, MANUAL (ESP model)
4-205-687-21	INSTRUCTION, MANUAL (FR model)
4-205-687-31	INSTRUCTION, MANUAL (UK model)
4-205-687-41	INSTRUCTION, MANUAL (AEP model)
4-205-687-51	INSTRUCTION, MANUAL (ESP model)
4-205-687-61	INSTRUCTION, MANUAL (AEP model)

\*\*\*\*\*

REMOTE COMMANDER  
\*\*\*\*\*

1-476-246-11	REMOTE COMMANDER (RM-814) (AEP/ESP model)
1-476-247-11	REMOTE COMMANDER (RM-815) (UK model)
1-476-248-11	REMOTE COMMANDER (RM-816) (FR model)
9-882-043-01	POCKET, COVER (FOR RM-814/815/816)